



October 2016

Illinois Power Generating Company
134 CIPS Lane
Coffeen, IL 62017

**RE: History of Construction
USEPA Final CCR Rule, 40 CFR § 257.73(c)
Coffeen Power Station
Coffeen, Illinois**

On behalf of Illinois Power Generating Company, AECOM has prepared the following history of construction for Ash Pond No. 1, Ash Pond No. 2, the GMF Pond, and the GMF Recycle Pond at the Coffeen Power Station in accordance with 40 CFR § 257.73(c).

BACKGROUND

40 CFR § 257.73(c)(1) requires the owner or operator of an existing coal combustion residual (CCR) surface impoundment that either (1) has a height of five feet or more and a storage volume of 20 acre-feet or more, or (2) has a height of 20 feet or more to compile a history of construction by October 17, 2016 that contains, to the extent feasible, the information specified in 40 CFR § 257.73(c)(1)(i)–(xii).

The history of construction presented herein was compiled based on existing documentation, to the extent that it is reasonably and readily available (see 80 Fed. Reg. 21302, 21380 [April 17, 2015]), and AECOM's site experience. AECOM's document review included record drawings, geotechnical investigations, construction specifications, etc. for Ash Pond No. 1, Ash Pond No. 2, the GMF Pond, and the GMF Recycle Pond at the Coffeen Power Station.

HISTORY OF CONSTRUCTION

§ 257.73(c)(1)(i): The name and address of the person(s) owning or operating the CCR unit; the name associated with the CCR unit; and the identification number of the CCR unit if one has been assigned by the state.

Owner: Illinois Power Generating Company

Address: 1500 Eastport Plaza Drive
Collinsville, IL 62234

CCR Units: Ash Pond No. 1
Ash Pond No. 2
GMF Pond, IDNR Dam ID No. IL50579
GMF Recycle Pond, IDNR Dam ID No. IL50578

Ash Pond No. 1 and Ash Pond No. 2 do not have a state assigned identification number.

§ 257.73(c)(1)(ii): The location of the CCR unit identified on the most recent USGS 7¹/₂ or 15 minute topographic quadrangle map or a topographic map of equivalent scale if a USGS map is not available.

The locations of Ash Pond No. 1, Ash Pond No. 2, the GMF Pond, and the GMF Recycle Pond have been identified on an USGS 7-1/2 minute topographic quadrangle map in **Appendix A**.

§ 257.73(c)(1)(iii): A statement of the purpose for which the CCR unit is being used.

The following captures the purposes of the CCR units:

- Ash Pond No. 1 is being used to store and dispose of bottom ash and other-non-CCR waste and to clarify recycled process water for plant operations. Ash Pond No. 2 (inactive) was used to store and dispose of bottom ash and fly ash.
- The GMF Pond is being used to store and dispose of gypsum and to clarify recycled process water for plant operations.
- The GMF Recycle Pond was used to store and dispose of gypsum from the plant's scrubber operations prior to the in-service date of the GMF Pond in 2010. The GMF Recycle Pond currently only receives and stores clear process water from the GMF Pond.

Notice of intent to close Ash Pond No. 2 was provided in November, 2015.¹

¹ This history of construction report was prepared on a facility-wide basis for CCR surface impoundments at the Coffeen Power Station. The inclusion of Ash Pond No. 2 in this history of construction report does not concede and should not be construed to concede that Ash Pond No. 2 is subject to the Design Criteria or all Operating Criteria in the CCR Rule.

§ 257.73(c)(1)(iv): The name and size in acres of the watershed where the CCR unit is located.

Ash Pond No. 1, Ash Pond No. 2, the GMF Pond, and the GMF Recycle Pond are located in the Coffeen Lake Watershed with a 12-digit Hydrologic Unit Code (HUC) of 071402030304 and a drainage area of 11,695 acres (USGS, 2016).

§ 257.73(c)(1)(v): A description of the physical and engineering properties of the foundation and abutment materials on which the CCR unit is constructed.

The foundation and abutment materials of Ash Pond No. 1, Ash Pond No. 2, the GMF Pond, and the GMF Recycle Pond consist of native fine-grained soils of wind-blown origin (loess), with some coarse-grained layers, underlain by glacial till. The physical properties of the fine-grained soils are described as low- to medium-plasticity silty clay, sandy lean clay, or lean clay with sand, often with trace amounts of gravel; or high plasticity fat clay, often with trace amounts of sand. The clay soils vary from soft to very stiff, moist to wet, and brown to gray. The physical properties of the coarse-grained soils are described as clayey sand, silty sand, or fine to coarse sand, with trace amounts of gravel. The sand is wet and varies from loose to dense and brown to gray. A thin layer of native silty or sandy lean clay is located immediately above the glacial till deposits. The clay is very soft to medium stiff, low to medium plasticity, wet, and orange brown to gray. The physical properties of the glacial till are described as lean clay, or silty to sandy lean clay, with trace amounts of fine gravel, hard, low plasticity, moist to wet, and brown to gray. An available summary of the engineering property typical ranges of the foundation and abutment materials is presented in **Table 1** below. The engineering properties are based on previous geotechnical explorations and laboratory testing.

Ash Pond No. 1 and Ash Pond No. 2 are enclosed impoundments with embankments and do not have abutments. The GMF Pond and GMF Recycle Pond were constructed as incised impoundments enclosed by embankments.

Table 1. Summary of Foundation and Abutment Material Engineering Properties

Material	Unit Weight (pcf)	Effective (drained) Shear Strength Parameters		Total (undrained) Shear Strength Parameters	Post-Earthquake Shear Strength
		Cohesion, c' (psf)	Friction Angle, ϕ' (deg)	S_u/p'	S_{ur}/p'
Foundation Clay (Under Embankment)	125	0	32	$S_u/p' = 0.39-0.45$, Min. $S_u = 700$ psf	Peak Undrained
Foundation Clay (Free Field)	125	0	30	$S_u/p' = 0.24-0.28$, Min. $S_u = 450$ psf	Peak Undrained
Soft Foundation Clay	125	0	30	$S_u/p' = 0.22-0.28$, Min. $S_u = 275$ psf	$S_u/p' = 0.13-0.16$, Min. $S_{ur} = 200$ psf
Glacial Till	135	0	40	$S_u/p' = 0.45-0.64$, Min. $S_u = 700$ psf	Peak Undrained

§ 257.73(c)(1)(vi): A statement of the type, size, range, and physical and engineering properties of the materials used in constructing each zone or stage of the CCR unit; the method of site preparation and construction of each zone of the CCR unit; and the approximate dates of construction of each successive stage of construction of the CCR unit.

Physical properties for the embankment construction materials for Ash Pond No. 1, Ash Pond No. 2, GMF Pond, and GMF Recycle Pond are described as silty clay, sandy lean clay, or lean clay with sand, with trace amounts of fine gravel. The fill is soft to very stiff in consistency, low to medium plasticity, moist to wet, and brown to gray. Trace amounts of organic material and ash are present. The embankment fill generally appears to be well-compacted. An available summary of the engineering properties of the embankment construction materials is presented in **Table 2** below. The engineering properties are based on previous geotechnical explorations and laboratory testing.

Table 2. Summary of Construction Material Engineering Properties for Embankments

Material	Unit Weight (pcf)	Peak Drained Shear Strength		Peak Undrained Shear Strength	Post-Earthquake Shear Strength
		Cohesion, c' (psf)	Friction Angle, f' (deg)	S_u/p'	S_{ur}/p'
Embankment Fill	135	0	31	$S_u/p' = 0.60$, Min. $S_u = 450$ psf	Peak Undrained

The GMF Pond and GMF Recycle Pond contain liner systems. The liner system within the GMF Pond consists of a 60-mil textured high density polyethylene (HDPE) geomembrane underlain by a 3-foot thick layer of compacted clay. A typical cross section profile of the GMF Pond liner system is shown on drawing C-10206 (sh. 9) presented in **Appendix B**. An available summary of the engineering properties of the GMF Pond liner construction materials from Hanson (2008) is presented in **Table 3** below. The liner system within the GMF Recycle Pond consists of a 60-mil textured HDPE geomembrane underlain by smooth-drum rolled native soil. A typical cross section profile of the GMF Recycle Pond liner system is shown on drawing C-10206 (sh. 20) presented in **Appendix B**.

Table 3. Summary of Construction Material Engineering Properties for Liner

Material	Unit Weight (pcf)	Effective (drained) Shear Strength Parameters		Total (undrained) Shear Strength Parameters	
		c' (psf)	Φ' (°)	c (psf)	Φ (°)
Clay Liner	121.2	0	28.3	1950	0

The method of site preparation and construction of Ash Pond No. 1 and Ash Pond No. 2 is not reasonably and readily available. Site preparation and construction of the GMF Pond and GMF Recycle Pond were completed in accordance with the applicable construction specification (see § 257.73(c)(1)(xi) below).

The approximate dates of construction of each successive stage of construction of Ash Pond No. 1, Ash Pond No. 2, the GMF Pond, and the GMF Recycle Pond are provided in **Table 4** below.

Table 4. Approximate dates of construction of each successive stage of construction.

Date	Event
1964	Construction of Ash Pond No. 1
1971	Construction of Ash Pond No. 2
1978-1979	Installation of internal embankment and new recycle intake structure in Ash Pond No. 1 and abandonment of existing outfall structure
1984-1985	Closure of Ash Pond No. 2 by installing a clay cover
2000	Installation of a sheet pile wall to facilitate construction of drainage flume along the northeast corner of the Ash Pond No. 1
2009	Installation of well dewatering system in Ash Pond No. 2
2008-2010	Construction of the GMF Pond and the GMF Recycle Pond

§ 257.73(c)(1)(vii): At a scale that details engineering structures and appurtenances relevant to the design, construction, operation, and maintenance of the CCR unit, detailed dimensional drawings of the CCR unit, including a plan view and cross sections of the length and width of the CCR unit, showing all zones, foundation improvements, drainage provisions, spillways, diversion ditches, outlets, instrument locations, and slope protection, in addition to the normal operating pool surface elevation and the maximum pool surface elevation following peak discharge from the inflow design flood, the expected maximum depth of CCR within the CCR surface impoundment, and any identifiable natural or manmade features that could adversely affect operation of the CCR unit due to malfunction or mis-operation.

Drawings that contain items pertaining to the requested information for Ash Pond No. 1, Ash Pond No. 2, the GMF Pond, and the GMF Recycle Pond are listed in **Table 5** below. Items marked as "Not Available" are items not found during a review of the reasonably and readily available record documentation.

Table 5. List of drawings containing items pertaining to the information requested in § 257.73(c)(1)(vii).

	Ash Pond No. 1	Ash Pond No. 2	GMF Pond	GMF Recycle Pond
Dimensional plan view (all zones)	B-35, S-44, S-45	B-560, A1000 (sh. 1)	C-10206 (sh. 4, 9, 10)	C-10206 (sh. 4, 19)
Dimensional cross sections	B-35, S-47 to S-50	B-561	C-10206 (sh. 9)	C-10206 (sh. 20)
Foundation Improvements	Not Applicable	Not Applicable	C-10206 (sh. 10)	C-10206 (sh. 20)
Drainage Provisions	Not Applicable	A1000 (sh. 4)	C-10206 (sh. 15, 16, 20)	C-10206 (sh. 21)
Spillways and Outlets	S-8, S-49	W1008 (sh. 2)	C-10206 (sh. 20)	C-10206 (sh. 22)
Diversion Ditches	Not Applicable	A1000 (sh. 1)	Not Applicable	Not Applicable
Instrument Locations	Plate 2, Figure 2A	Figure 2B	Not Applicable	C-10206 (sh. 19)
Slope Protection	S-49	B-561	C-10206 (sh. 9)	C-10206 (sh. 20)
Normal Operating Pool Elevation	S-8, S-49	Not Applicable	C-10201-25	Not Available
Maximum Pool Elevation	S-8	Not Applicable	C-10201-25	Not Available
Approximate Maximum Depth of CCR in 2016	15 feet	28 feet	16 feet	12 feet

All drawings referenced in **Table 5** above can be found in **Appendix B** and **Appendix C**.

Based on the review of the drawings listed above, no natural or manmade features that could adversely affect operation of these CCR units due to malfunction or mis-operation were identified.

§ 257.73(c)(1)(viii): A description of the type, purpose, and location of existing instrumentation.

Existing instrumentation at Ash Pond No. 1 and Ash Pond No. 2 include vibrating-wire and open-standpipe piezometers. The purpose of the piezometers is to measure the phreatic surface within and around the impoundments. Two (2) open-standpipe piezometers (AP-P1 and AP-P2) were installed at Ash Pond No. 2 in 2009 and the locations are presented on Figure 2A in **Appendix C**. Two (2) open-standpipe piezometers (B-2 and B-4) were installed at Ash Pond No. 1 in 2010 and the locations are presented on Plate 2 in **Appendix C**. Twelve (12) open-standpipe and vibrating-wire piezometers were installed at Ash Pond No. 1 and Ash Pond No. 2 in 2015 and the locations are presented on Figure 2A in **Appendix C**.

The GMF Pond does not contain existing instrumentation. Existing instrumentation at the GMF Recycle Pond consists of one (1) ultrasonic level transmitter. The purpose of the ultrasonic level transmitter is to measure the water level within the GMF Recycle Pond. The location of the ultrasonic level transmitter is shown on drawing C-10206 (sh. 19) presented in **Appendix B**.

§ 257.73(c)(1)(ix): Area-capacity curves for the CCR unit.

Area-capacity curves for Ash Pond No. 2 and the GMF Recycle Pond are not reasonably and readily available. The area-capacity curves for Ash Pond No. 1 and the GMF Pond are presented in **Figures 1 and 2**, respectively, below. “Area-capacity curves”, as defined by 40 CFR § 257.53, “means graphic curves which readily show the reservoir water surface area, in acres, at different elevations from the bottom of the reservoir to the maximum water surface, and the capacity or volume, in acre-feet, of the water contained in the reservoir at various elevations.”

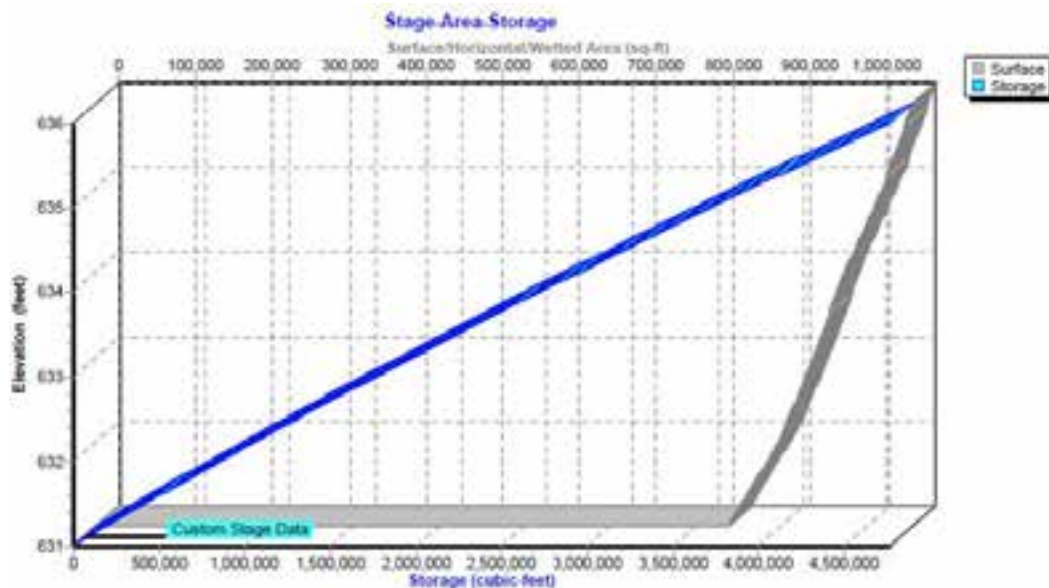

Figure 1. Area-capacity curve for Ash Pond No. 1

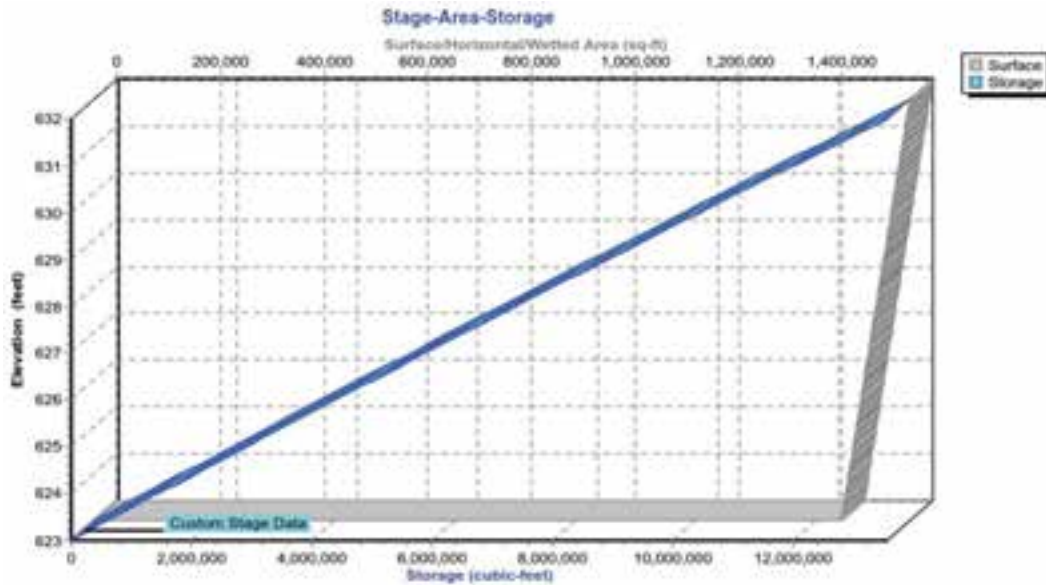

Figure 2. Area-capacity curve for GMF Pond

The area-capacity curves shown were taken from the pond modeling analysis. Actual pond capacity is limited to the approximate berm elevation listed in **Table 6** below. Any information above berm elevation should be disregarded.

§ 257.73(c)(1)(x): A description of each spillway and diversion design features and capacities and calculations used in their determination.

Ash Pond No. 1 contains a concrete intake structure that drains into a 48-inch diameter (dia.) steel pipe. The steel pipe leads to the recycle pump house. In 2016, the discharge capacity of Ash Pond No. 1 was evaluated using HydroCAD 10 software modeling a 1,000-year, 24-hour rainfall event. The results of the HydroCAD 10 analysis are presented below in **Table 6**.

Ash Pond No. 2 was closed in 1984-1985 by installing a clay cover. Non-contact stormwater is collected in ditches along the clay cover and drain off the pond cover via concrete-lined ditch outlets. CCR-contact stormwater collected within the pond is pumped into the GMF Pond via the well dewatering system at the discretion of plant personnel. The capacity of the diversion ditches and well pumps during a model rainfall event has not been evaluated.

The GMF Pond contains a 14-inch high-density polyethylene (HDPE) pipe culvert for normal flow and a weir-like spillway for high water flow. The GMF Pond also contains a 10-inch dia. HDPE siphon pipe used for dewatering. In 2016, the discharge capacity of the GMF Pond was evaluated using HydroCAD 10 software modeling a 1,000-year, 24-hour rainfall event. The results of the HydroCAD 10 analysis are presented below in **Table 6**.

The GMF Recycle Pond contains a decant structure that drains into two (2) 18-inch dia. HDPE pipes that lead to a pump house. The capacity of the decant structure during a model rainfall event has not been evaluated.

Table 6. Results of HydroCAD 10 analyses

	Ash Pond No. 1	GMF Pond
Approximate Minimum Berm Elevation ¹ (ft)	635.0	631.0
Approximate Emergency Spillway Elevation ¹ (ft)	Not Applicable	624.0
Starting Pool Elevation ¹ (ft)	631.0	621.2
Peak Elevation ¹ (ft)	632.0	623.8
Time to Peak (hr)	24.4	24.1
Surface Area (ac)	20.4	33.4
Storage ² (ac-ft)	19.5	88.3

Note: 1. Elevations are based on NAVD88 datum
 2. Storage given is from Starting Pool Elevation to Peak Elevation.

§ 257.73(c)(1)(xi): The construction specifications and provisions for surveillance, maintenance, and repair of the CCR unit.

The construction specifications for Ash Pond No. 1 and Ash Pond No. 2 are not reasonably and readily available. The construction specifications for the GMF Pond and the GMF Recycle Pond are located in *Project Specifications, Gypsum Stack and Recycle Pond Construction* presented in **Appendix D**.

The provisions for surveillance, maintenance, and repair of Ash Pond No. 1 are located in *Operation & Maintenance Manual for #1 Ash Pond* presented in **Appendix E**. The provisions for surveillance, maintenance, and repair of Ash Pond No. 2 are not reasonably and readily available. The provisions for surveillance, maintenance, and repair of the GMF Pond and the GMF Recycle Pond are located in *Operation and Maintenance Manual, Gypsum Management Facility* presented in **Appendix F**.

The operations and maintenance plans for the CCR units identified in this report are currently being revised by Illinois Power Generating Company.

§ 257.73(c)(1)(xii): Any record or knowledge of structural instability of the CCR unit.

In March, 2009, shallow sloughing was observed along the eastern embankment of Ash Pond No. 2. The sloughing was inspected by Hanson Professional Services Inc. A dewatering

system was installed in Ash Pond No. 2 to lower the phreatic surface within the pond. In December, 2015, additional sloughing was observed on the embankment of Ash Pond No. 2 and on the embankment of Ash Pond No. 1. The sloughing was believed to be caused by recent heavy rains and was repaired. Photos of the 2015 sloughing repair are presented in **Appendix G**.

There is no record or knowledge of structural instability at the GMF Pond and the GMF Recycle Pond at Coffeen Power Station.

LIMITATIONS

The signature of AECOM's authorized representative on this document represents that to the best of AECOM's knowledge, information and belief in the exercise of its professional judgment, it is AECOM's professional opinion that the aforementioned information is accurate as of the date of such signature. Any recommendation, opinion or decisions by AECOM are made on the basis of AECOM's experience, qualifications and professional judgment and are not to be construed as warranties or guaranties. In addition, opinions relating to environmental, geologic, and geotechnical conditions or other estimates are based on available data and that actual conditions may vary from those encountered at the times and locations where data are obtained, despite the use of due care.

Sincerely,



Claudia Prado
Program Manager



Victor Modeer, P.E., D.GE
Senior Project Manager

REFERENCES

Hanson Professional Services Inc. (2008), *Support Document for IDNR/OWR Permit Application, Coffeen Power Generating Station Gypsum Management Facility Montgomery County, Illinois*

United States Environmental Protection Agency (USEPA). (2015). *Hazardous and Solid Waste Management System; Disposal of Coal Combustion Residuals From Electric Utilities; Final Rule*. 40 CFR Parts 257 and 261, 80 Fed. Reg. 21302, 21380 April 17, 2015.

United States Geological Survey (USGS). (2016). The National Map Viewer. <http://viewer.nationalmap.gov/viewer/>. USGS data first accessed in March of 2016.

APPENDICES

Appendix A: History of Construction Vicinity Map

Appendix B: Coffeen Power Station Drawings

Appendix C: Coffeen Power Station Boring and Piezometer Locations

Appendix D: Project Specifications, Gypsum Stack and Recycle Pond Construction (Hanson 2008)

Appendix E: Operation & Maintenance Manual for #1 Ash Pond

Appendix F: Operation and Maintenance Manual, Gypsum Management Facility Operation (2015)

Appendix G: Photos of 2015 Sloughing Repair



Appendix A: History of Construction Vicinity Map

AECOM DRAWING PATH: P:\Projects\Geotech\60428794_DyregyCCR\13_Construction\History\04_Technical\Production\10_Coffeen\References\Figures\C-01_History of Construction Vicinity Map (Coffeen)_ZLF.dwg
 NAVAK, MATT, 8/30/2016 10:52 AM

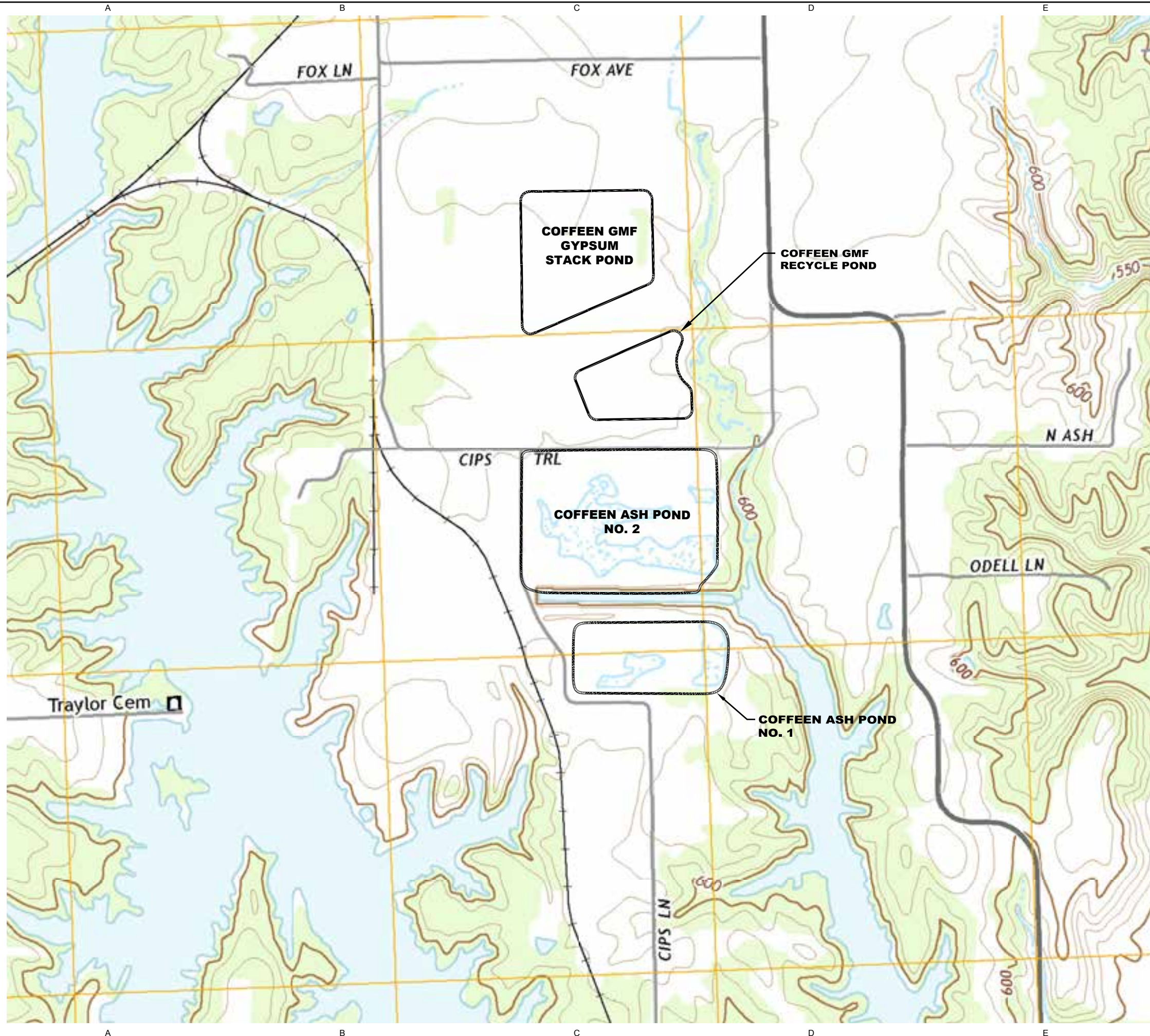

LEGEND
 CCR UNITS

SOURCE:
 MAP PROVIDED FROM ELECTRONIC
 USGS DIGITAL RASTER GRAPHIC 7.5
 MINUTE TOPOGRAPHIC MAP OF
 COFFEEN, ILLINOIS, REVISED 2015.

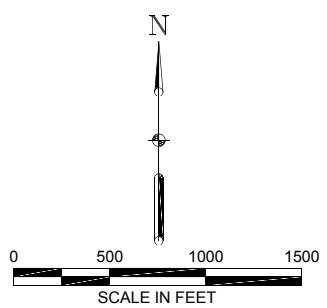

AECOM
 1001 Highlands Plaza Drive, Suite 300
 St. Louis, Mo. 63110
 314 429-0100 (phone)
 314 429-0462 (fax)

**ILLINOIS POWER
 GENERATING COMPANY**
 134 CIPS Lane
 Coffeen, IL 62017

**HISTORY OF
 CONSTRUCTION**
 COFFEEN POWER STATION
 COFFEEN, ILLINOIS

ISSUED FOR BIDDING _____ DATE BY _____

ISSUED FOR CONSTRUCTION _____ DATE BY _____

REVISIONS		
NO.	DESCRIPTION	DATE
△		
△		
△		
△		
△		

AECOM PROJECT NO: 60489731
 DRAWN BY: DJD
 DESIGNED BY: DJD
 CHECKED BY: MN
 DATE CREATED: 2016-04-13
 PLOT DATE:
 SCALE: 1" = 500'
 ACAD VER: 2014

SHEET TITLE
 HISTORY OF
 CONSTRUCTION
 VICINITY MAP



Appendix B: Coffeen Power Station Drawings

1. "Earthwork & Grading Plan", Drawing No. B-35, Revision S, 8 September, 1995, Sargent & Lundy Engineers.
2. "Concrete Recycle Pump House – Intake Structure", Drawing No. S-8, Revision 6, 23 February, 1996, Stearns-Roger Incorporated.
3. "Civil Layout & Grading Plan Sheet 4", Drawing No. S-44, Revision 6, 23 February, 1996, Stearns-Roger Incorporated.
4. "Civil Layout & Grading Plan Sheet 5", Drawing No. S-45, Revision 9, 23 February, 1996, Stearns-Roger Incorporated.
5. "Civil Miscellaneous Sections and Details, Sheet 2", Drawing No. S-47, Revision 2, 23 February, 1996, Stearns-Roger Incorporated.
6. "Civil Ash Pond No 1 – Sections and Details", Drawing No. S-48, Revision 2, 23 February, 1996, Stearns-Roger Incorporated.
7. "Civil Miscellaneous Sections and Details, Sheet 4", Drawing No. S-49, Revision 4, 23 February, 1996, Stearns-Roger Incorporated.
8. "Civil Miscellaneous Sections and Details", Drawing No. S-50, Revision 4, 23 February, 1996, Stearns-Roger Incorporated.
9. "Ash Storage Area, Plan", Drawing No. B-560, Revision A, 9 February, 1971, Sargent & Lundy Engineers.
10. "Ash Storage Area, Sections & Details", Drawing No. B-561, Revision A, 9 February, 1971, Sargent & Lundy Engineers.
11. "Overall Site Plan, Dewatering System, Ash Pond #2", Drawing No. A1000 (sh. 1), Revision A, 12 October, 2009, Ameren Energy Resources Generating.
12. "Site Details, Dewatering System, Ash Pond #2", Drawing No. A1000 (sh. 4), Revision A, 12 October, 2009, Ameren Energy Resources Generating.
13. "Proposed Site Plan, CCB Management Facility", Drawing No. C-10206 (sh. 4), Revision 0, 5 January, 2011, Ameren Energy Generating.
14. "Groundwater Monitoring & Boring Plan, CCB Management Facility", Drawing No. C-10206 (sh. 5), Revision 0, 5 January, 2011, Ameren Energy Generating.
15. "Anchor Trench and Liner System, CCB Management Facility", Drawing No. C-10206 (sh. 9), Revision 0, 5 January, 2011, Ameren Energy Generating.
16. "Cell G1-Foundation Grade & Control Data, CCB Management Facility", Drawing No. C-10206 (sh. 10), Revision 0, 5 January, 2011, Ameren Energy Generating.
17. "Cell G1-Process Water Recovery System, CCB Management Facility", Drawing No. C-10206 (sh. 15), Revision 0, 5 January, 2011, Ameren Energy Generating.
18. "Cell G1-PWRS Drain Details, CCB Management Facility", Drawing No. C-10206 (sh. 16), Revision 0, 5 January, 2011, Ameren Energy Generating.
19. "Recycle Pond Plan & Control Data, CCB Management Facility", Drawing No. C-10206 (sh. 19), Revision 0, 5 January, 2011, Ameren Energy Generating.
20. "Recycle Pond – Process Water Transfer Channel Details, CCB Management Facility", Drawing No. C-10206 (sh. 20), Revision 0, 5 January, 2011, Ameren Energy Generating.



Appendix B: Coffeen Power Station Drawings (continued)

21. "Recycle Pond–Process Water Decant Sections & Details, CCB Management Facility", Drawing No. C-10206 (sh. 21), Revision 0, 5 January, 2011, Ameren Energy Generating.
22. "Recycle Pond – Emergency Spillway Sections & Details, CCB Management Facility", Drawing No. C-10206 (sh. 22), Revision 0, 5 January, 2011, Ameren Energy Generating.
23. "Ash Pond #2, Drainage Modifications", Drawing No. W1008 (sh. 2), Ameren Energy Generating.

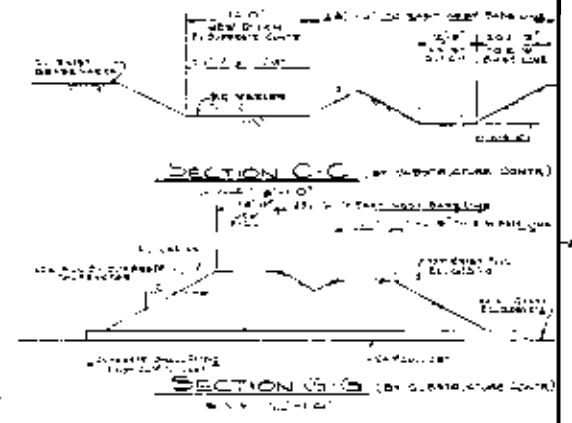
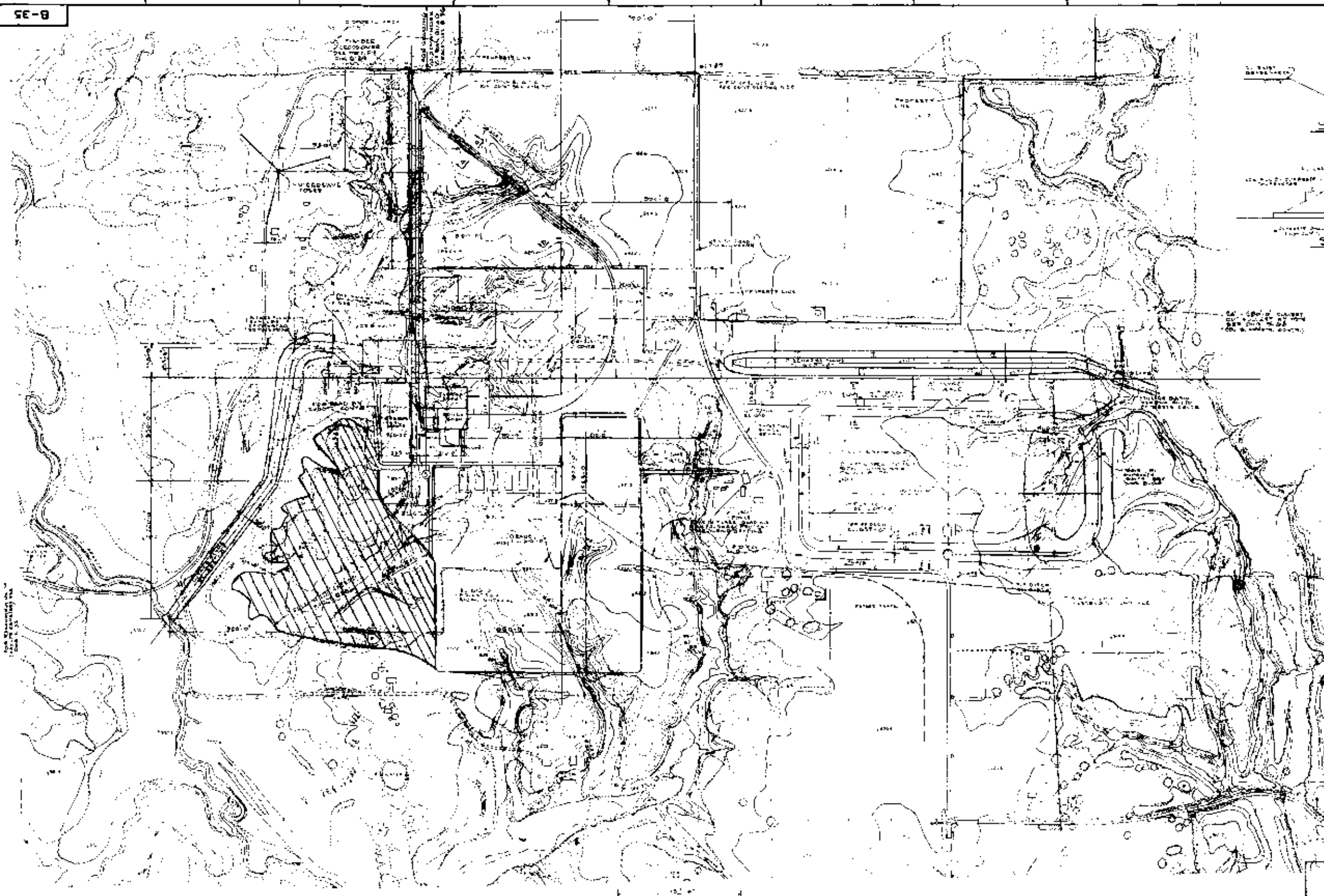

NOTES

- All work shall be done in accordance with the specifications and drawings for this project.
- Excavation shall be done in accordance with the specifications and drawings for this project.

REFERENCE DRAWINGS

- D-20 PRELIMINARY GRADING
- D-21 PROPOSED GRADING
- D-22 PROPOSED GRADING
- D-23 PROPOSED GRADING

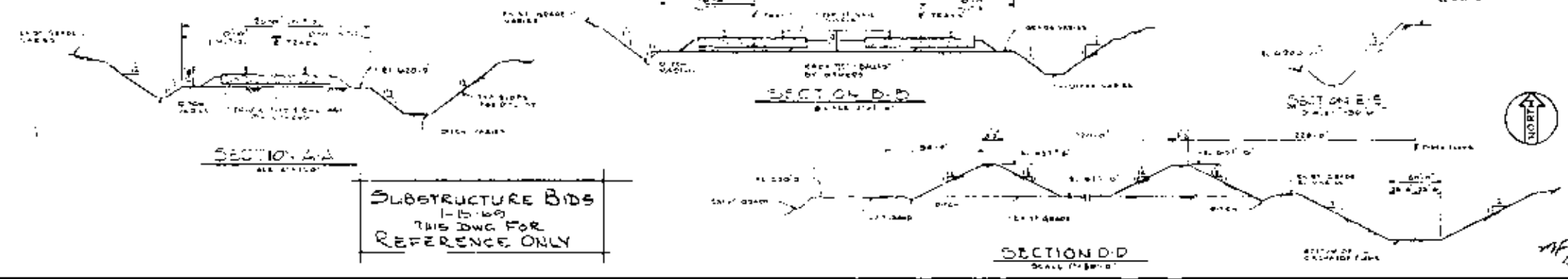

SUBSTRUCTURE BIDS
 1-15-69
 THIS DRAWING FOR
 REFERENCE ONLY

SCANNED BY SA

NO.	DESCRIPTION	DATE	BY
1	REVISION		
2	REVISION		
3	REVISION		
4	REVISION		
5	REVISION		
6	REVISION		
7	REVISION		
8	REVISION		
9	REVISION		
10	REVISION		
11	REVISION		
12	REVISION		
13	REVISION		
14	REVISION		
15	REVISION		
16	REVISION		
17	REVISION		
18	REVISION		
19	REVISION		
20	REVISION		

EARTHWORK & GRADING PLAN
UNIT I
COFFEEN POWER STATION
CENTRAL ILL. PUBLIC SERVICE CO.
COFFEEN, ILLINOIS

SARGENT & LUNDY
ENGINEERS
 CHICAGO, ILLINOIS
 DRAWING NO.
B-35

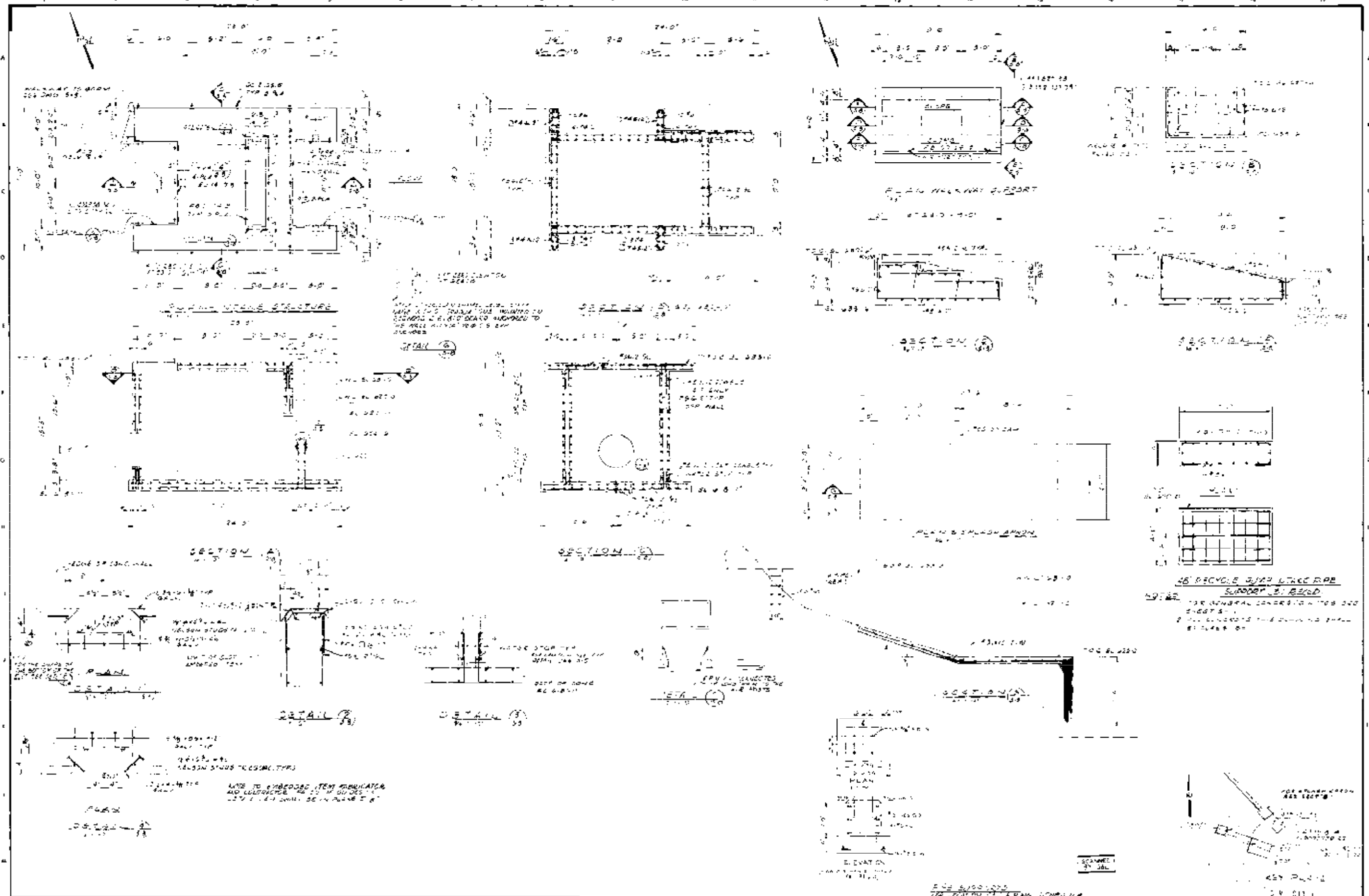

NO.	REVISIONS	REFERENCE DRAWINGS	PRINT RECORD		ENG. RECORD		DRAWING STATUS	
			DATE	BY	DATE	BY	DATE	BY
1	AS SHOWN	5-1, 5-2, 5-3, 5-4, 5-5, 5-6, 5-7, 5-8, 5-9, 5-10, 5-11, 5-12, 5-13, 5-14, 5-15, 5-16, 5-17, 5-18, 5-19, 5-20, 5-21, 5-22, 5-23, 5-24, 5-25, 5-26, 5-27, 5-28, 5-29, 5-30, 5-31, 5-32, 5-33, 5-34, 5-35, 5-36, 5-37, 5-38, 5-39, 5-40, 5-41, 5-42, 5-43, 5-44, 5-45, 5-46, 5-47, 5-48, 5-49, 5-50, 5-51, 5-52, 5-53, 5-54, 5-55, 5-56, 5-57, 5-58, 5-59, 5-60, 5-61, 5-62, 5-63, 5-64, 5-65, 5-66, 5-67, 5-68, 5-69, 5-70, 5-71, 5-72, 5-73, 5-74, 5-75, 5-76, 5-77, 5-78, 5-79, 5-80, 5-81, 5-82, 5-83, 5-84, 5-85, 5-86, 5-87, 5-88, 5-89, 5-90, 5-91, 5-92, 5-93, 5-94, 5-95, 5-96, 5-97, 5-98, 5-99, 5-100	11/11/11	J. J. JEL	11/11/11	J. J. JEL		



E 3,002,500 E 3,003,000 E 3,003,500

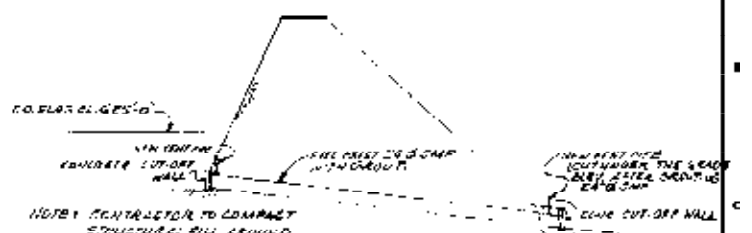
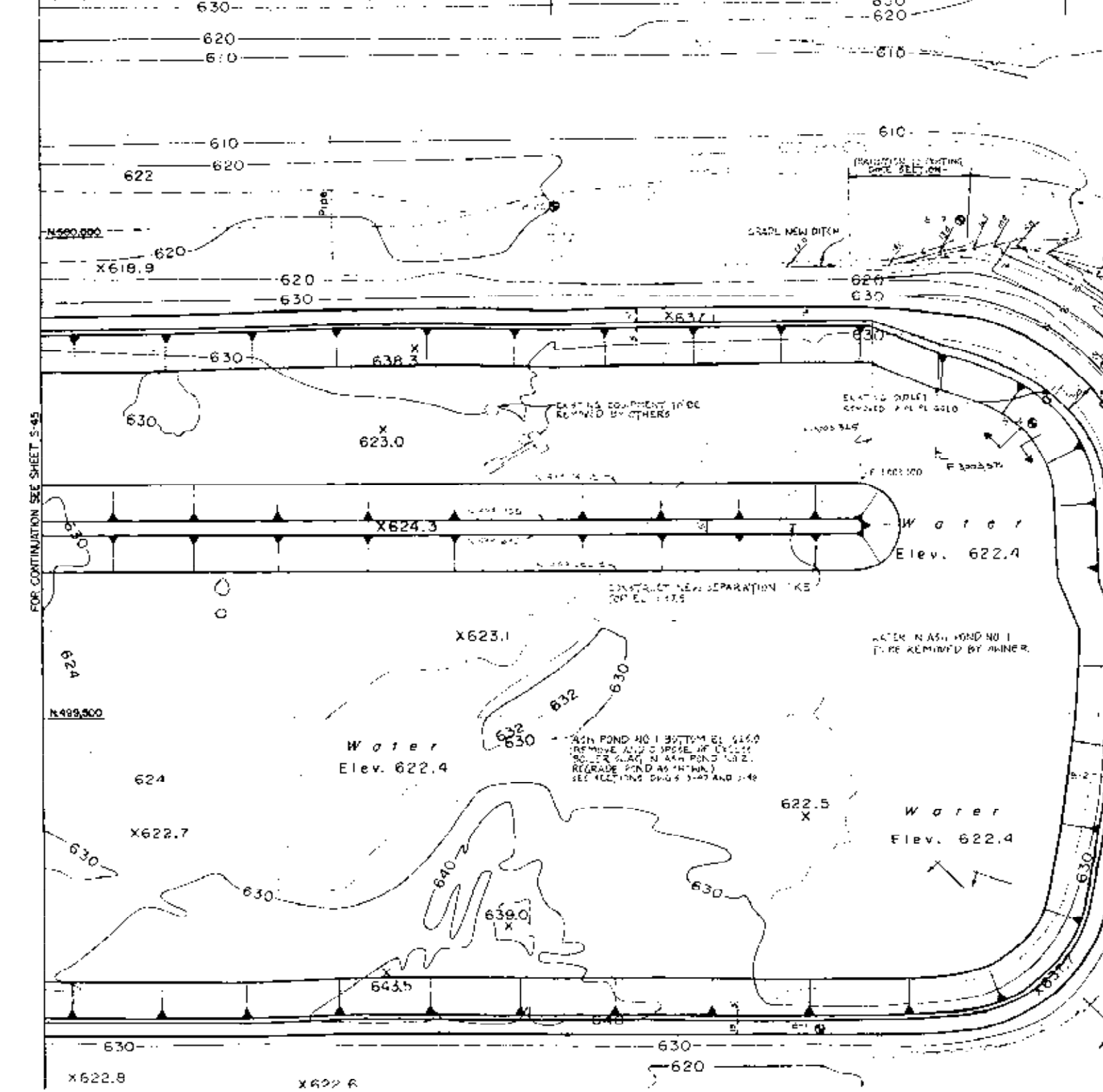

TRANSITION TO EXISTING DIKE SECTION
SEE DWG. S-44 FOR DETAIL

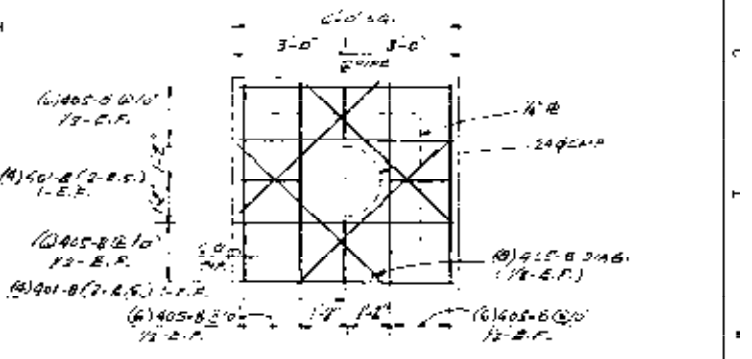
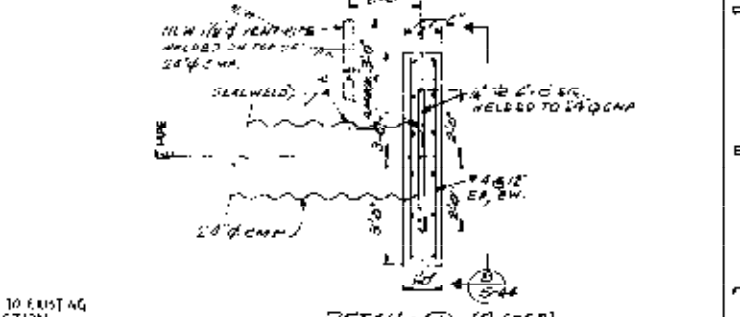

NOTES:
 1 FOR LEGEND SEE DWG. S-40.
 2 FOR ASH POND NO. 1 LAYOUT SECTION SEE DWG. S-46 & S-45.
 3 FOR SITE PLAN SEE DWG. S-40.

FOR CONTINUATION SEE SHEET S-45

N 499,500



REVISIONS			REFERENCE DRAWINGS	PRINT RECORD	ENG RECORD	DRAWING STATUS
NO.	DATE	DESCRIPTION				
1		GENERAL REVISIONS				
2		REVISIONS FOR CONSTRUCTION				
3		ADD SECTION 'A' & 'B' AND DETAIL 'T'				
4		REVISED AS PER COMMENTS AND APPROVAL				
5		REVISED AS PER COMMENTS AND APPROVAL				
6		REVISED AS PER COMMENTS AND APPROVAL				

CIVIL
 LAYOUT & GRADING PLAN SHEET 4
 WASTEWATER MANAGEMENT FACILITIES
 CENTRAL ILLINOIS PUBLIC SERVICE COMPANY
 DUFFEN POWER STATION
 STEARNS-ROGER
 S.R. NO. 12-4

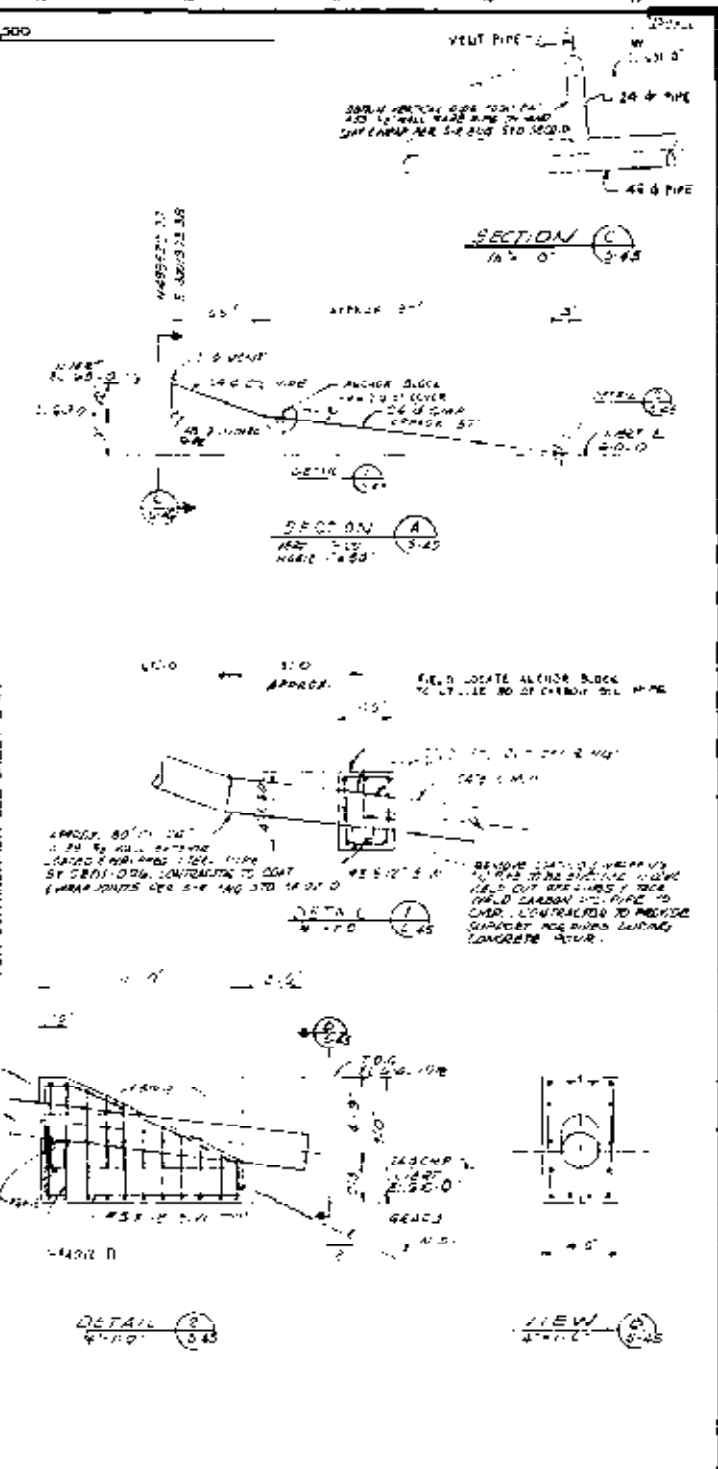
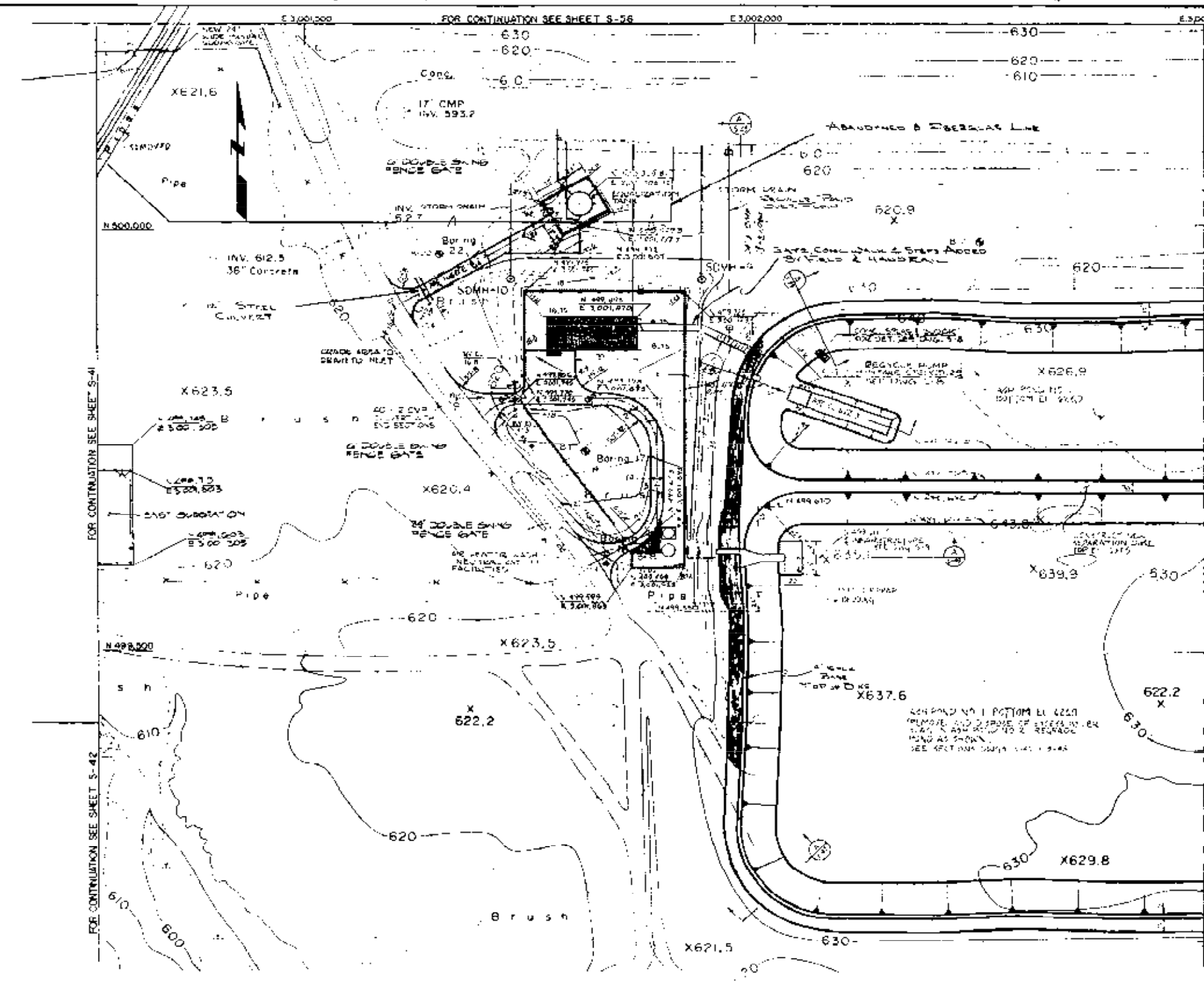

NOTES:
 1. FOR ROAD PROFILES AND SECTIONS SEE DWG S-43.
 2. FOR LEGEND SEE DWG S-40.
 3. FOR 18\"/>



NO.	REVISIONS	DATE
1	ADD L&S GEN. N.Y. DIMENSIONS FOR CONCRETE	10/15/11
2	ADDED SUBSTATION AND REVISED GATE SIZES	10/15/11
3	IF ARE CONCRETE TO BE BUILT	10/15/11
4	ADDED REVISIONS TO THE GATE SIZES	10/15/11
5	REV. GRADING	10/15/11
6	ADDED 4\"/>	

NO.	REFERENCE DRAWINGS
1	18\"/>
2	18\"/>
3	18\"/>
4	18\"/>

NO.	PRINT RECORD
1	18\"/>
2	18\"/>
3	18\"/>
4	18\"/>

NO.	END RECORD
1	18\"/>
2	18\"/>
3	18\"/>
4	18\"/>

NO.	DRAWING STATUS
1	18\"/>
2	18\"/>
3	18\"/>
4	18\"/>

S.R. NO Y2-5

CIVIL
LAYOUT & GRADING PLAN SHEET 5

WASTEWATER MANAGEMENT FACILITIES
CENTRAL ILLINOIS PUBLIC SERVICE COMPANY
COFFEE POWER PLANT

Stearns-Roger

DATE: 10/15/11
SCALE: AS SHOWN

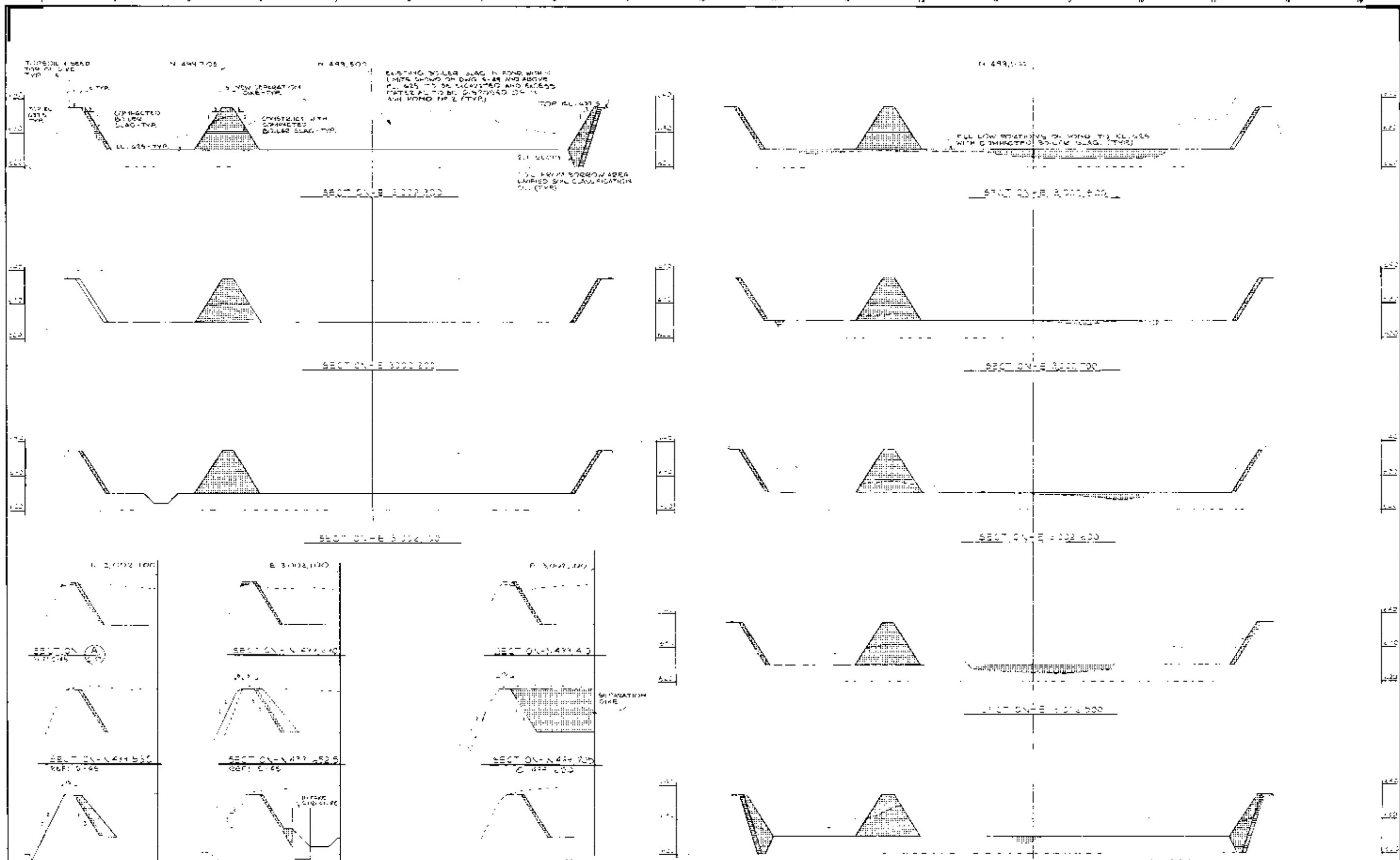

NOTES:
 1. FOR LEGEND SEE DWG. S-40
 2. FOR ABW POND H&I PLANS SEE DWGS. S-42 AND S-45
 3. FOR SITE PLAN SEE DWG. S-40

SCANNED BY E&L

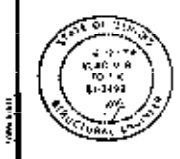

NO.	REVISIONS	REFERENCE DRAWINGS	PRINT RECORD	ENG. RECORD	DRAWING STATUS
1	APPROVED FOR CONSTRUCTION 11/10/45				
2					
3					
4					
5					
6					
7					
8					
9					
10					
11					
12					
13					
14					
15					
16					
17					
18					
19					
20					
21					
22					
23					
24					

SR NO Y2-7

CIVIL
 MISCELLANEOUS SECTIONS AND DETAILS
 SHEET 2

WASTEWATER WASTEWATER FACILITIES
 CENTRAL ILLINOIS PUBLIC SERVICE COMPANY
 GUYTON POWER STATION

Stearns-Roger

11/10/45
 E. J. Stearns
 ENGINEER

TOP EL. 511.5
FOR 15' DIKE
TOP-15

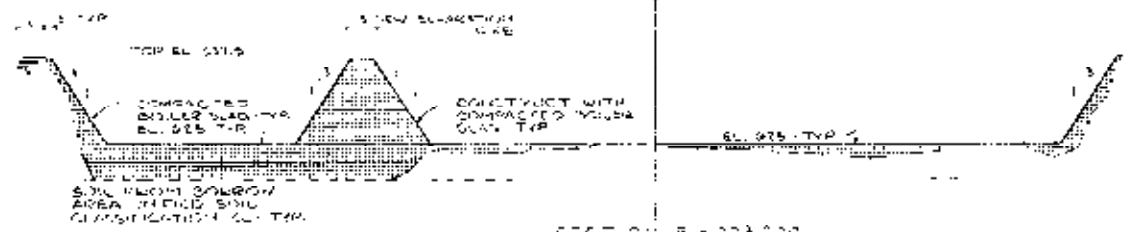

SECTION E 3003 200

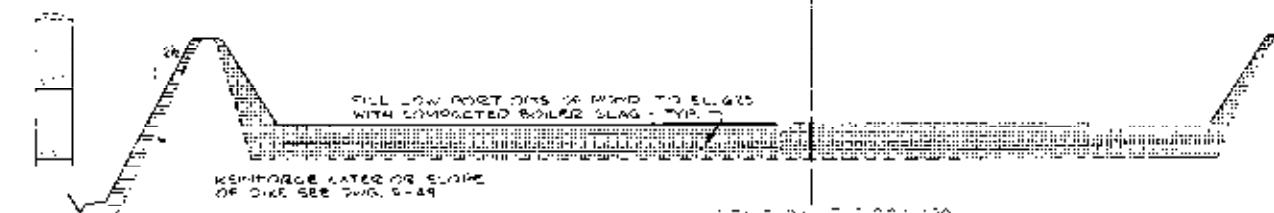

SECTION E 3004 400



SECTION E 3003 000

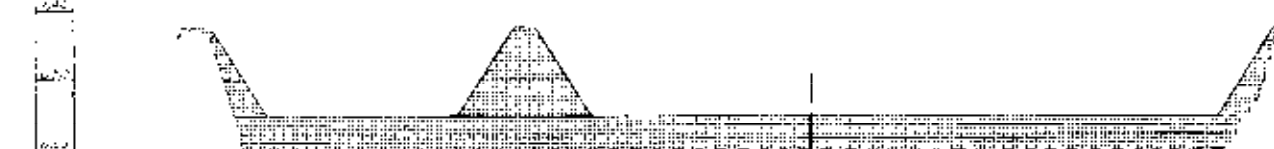

SECTION E 3003 800

EXISTING BOILER SLAG IN POND WITHIN LIMITS SHOWN ON DWG. S-48 AND ABOVE EL. 425 TO BE REMOVED AND AREA THEREAFTER TO BE FILLED OR IN ASH FROM THE 2' TYP.



SECTION E 3003 400



SECTION A 3003 400
REF. S-48

E 3003 400



SECTION B 3003 400
REF. S-48

E 3003 400



SECTION C 3003 400
REF. S-48



SECTION E 3003 600



SECTION A 3003 600
REF. S-48



SECTION B 3003 600
REF. S-48



SECTION C 3003 600
REF. S-48

NOTES:
1. FOR LAYOUT SEE DWG. S-40
2. FOR ASH POND 125' PLANS SEE DWG. S-48 AND S-49
3. FOR 15' PLANS SEE DWG. S-40

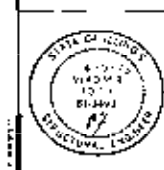

NO.	REVISIONS	DATE	BY	APP.
1	EMPHASIS	1/1/1990	SR	
2	REVISED	1/1/1990	SR	

NO.	REFERENCE DRAWINGS
1	ASH POND 125' PLANS SEE DWG. S-48 AND S-49
2	15' PLANS SEE DWG. S-40

DATE	BY	APP.
1/1/1990	SR	
1/1/1990	SR	

NO.	ENG. RECORD
1	DESIGNED BY SR
2	CHECKED BY SR
3	APPROVED BY SR

NO.	DRAWING STATUS
1	DESIGNED BY SR
2	CHECKED BY SR
3	APPROVED BY SR

SR NO Y2-B

CIVIL
ASH POND NO. 1 SECTIONS AND DETAILS

WASTEWATER MANAGEMENT FACILITIES
CENTRAL ILLINOIS PUBLIC SERVICE COMPANY
COFFEE POWER STATION

Stearns-Roger

DATE: 1/1/1990
SCALE: AS SHOWN

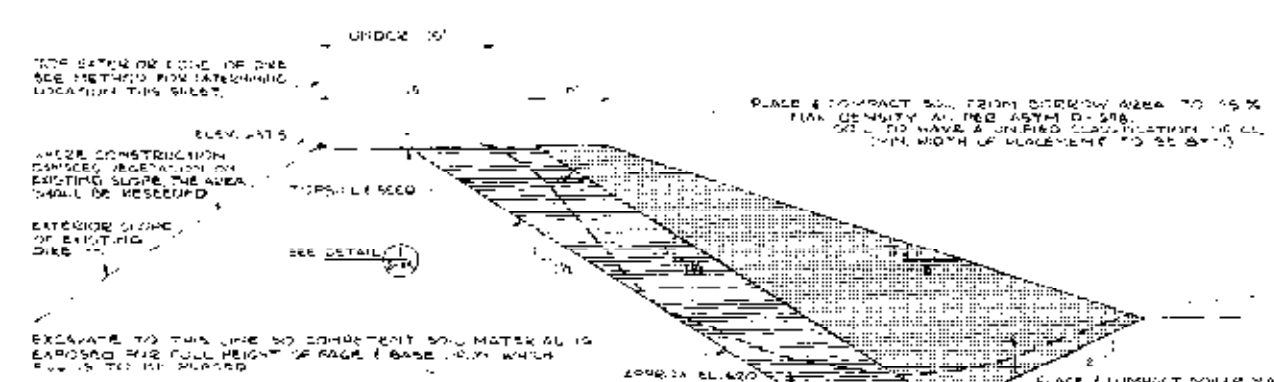

ASH POND NO. 1 SCALE 1"=10'
TYPICAL DIKE SECTION WHERE WIDTH OF EXISTING DIKE AT ELEVATION 531.5 IS UNDER 15'

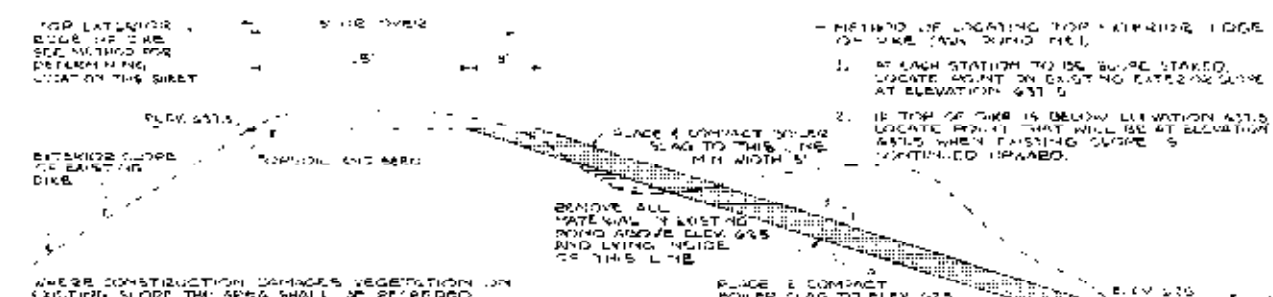

ASH POND NO. 1 SCALE 1"=10'
TYPICAL DIKE SECTION WHERE WIDTH OF EXISTING DIKE AT ELEVATION 531.5 IS 15' OR OVER

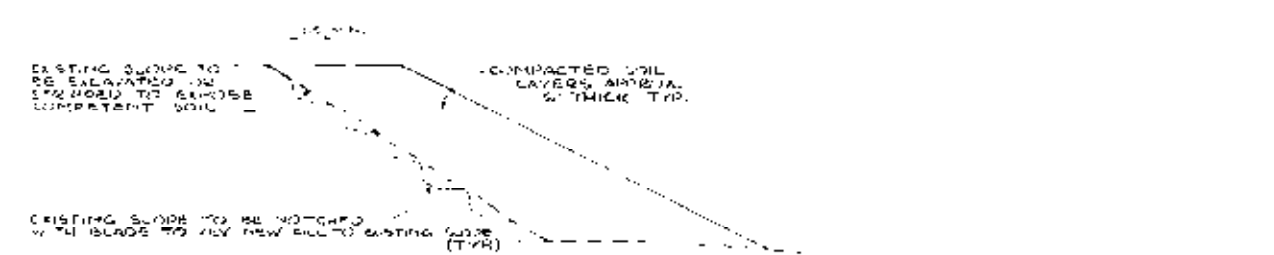

DETAIL 1/4"=1' SCALE
BLADING NEW FILL AGAINST EXISTING SLOPE

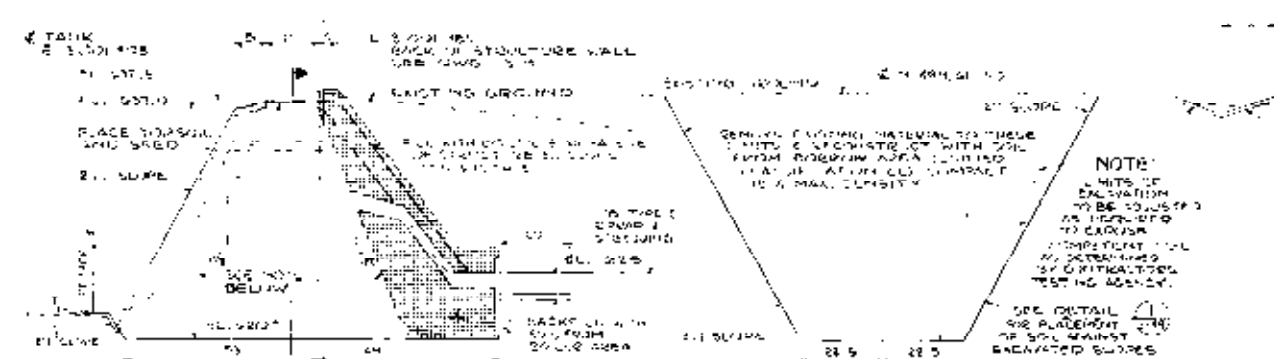

SECTION (A) SCALE 1/4"=1' PER 5'-25'

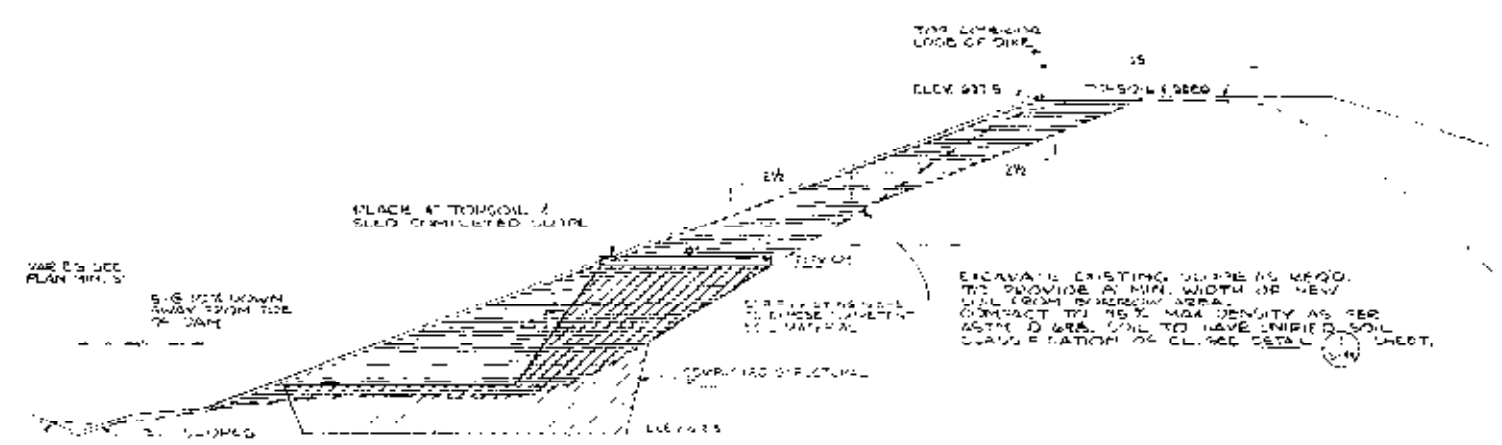

ASH POND NO. 1 SCALE 1"=10'
TYPICAL SECTION FOR BORROWING WHERE EXISTING DIKE IS 15' OR OVER

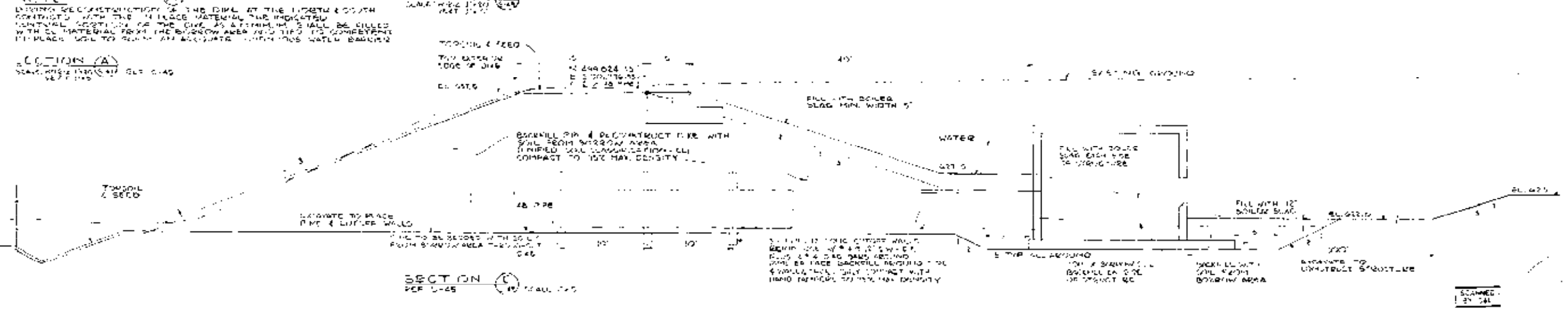

SECTION (C) PER 5'-25' SCALE 1/4"=1'

	REVISIONS NO. DATE BY DESCRIPTION 1 11/15/11 JLM GENERAL REVISIONS 2 11/15/11 JLM CORRECT CONSTRUCTION DETAILS 3 11/15/11 JLM CORRECT CONSTRUCTION DETAILS	REFERENCE DRAWINGS NO. DATE BY DESCRIPTION 1 11/15/11 JLM SEE PLAN SHEET 10	PRINT RECORD DATE BY DESCRIPTION 1 11/15/11 JLM PRINTED	ENG. RECORD NO. DATE BY DESCRIPTION 1 11/15/11 JLM CHECKED 2 11/15/11 JLM APPROVED	DRAWING STATUS NO. DATE BY DESCRIPTION 1 11/15/11 JLM CHECKED 2 11/15/11 JLM APPROVED	
	CIVIL MISCELLANEOUS SECTIONS & DETAILS SHEET 4					
	WASTEWATER MANAGEMENT FACILITIES CENTRAL ILLINOIS PUBLIC SERVICE COMPANY COOPER POWER PLANT					
	SCALE AS SHOWN 					

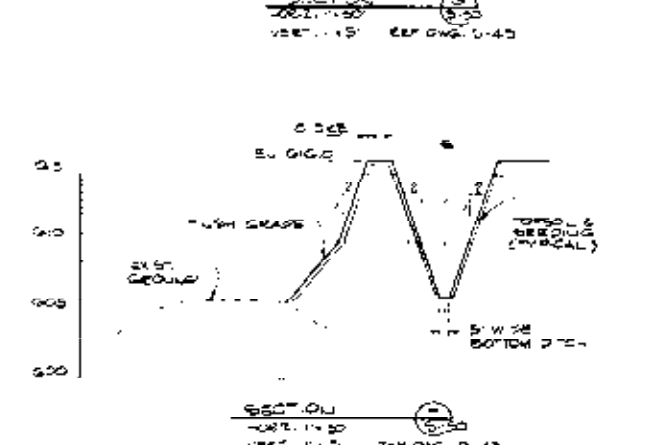
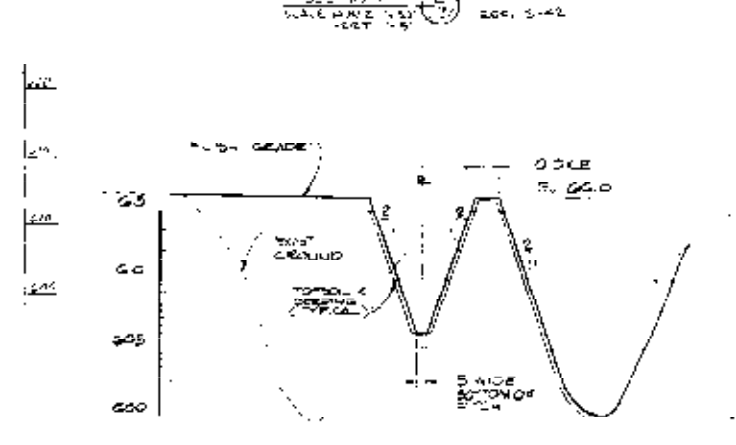
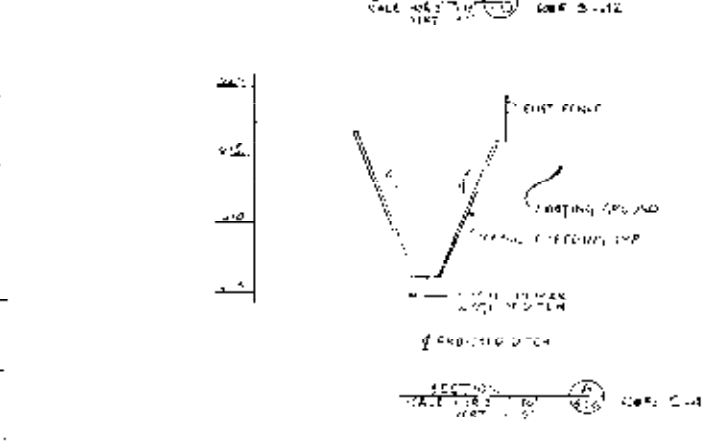
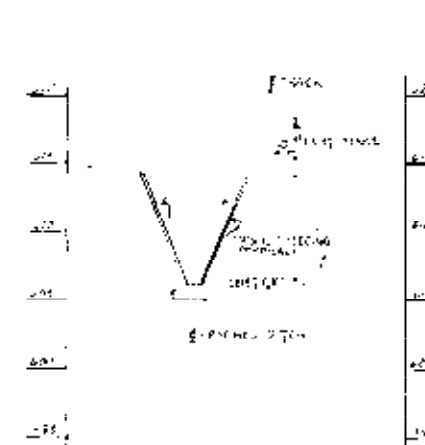
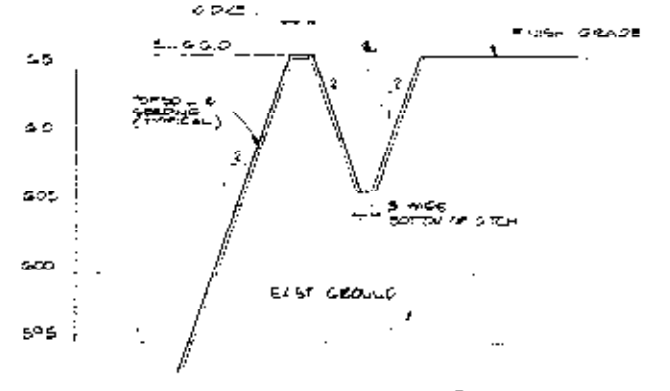
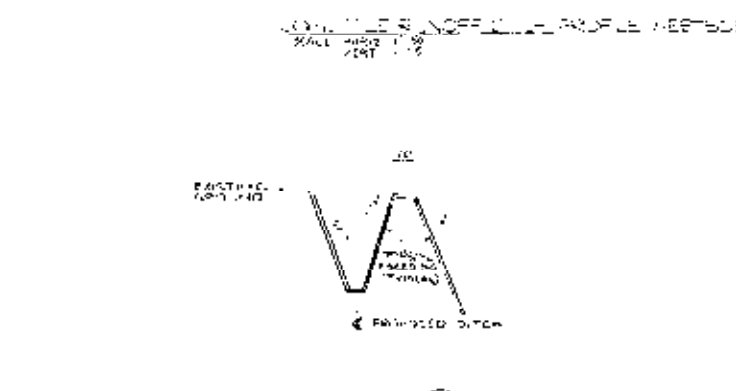
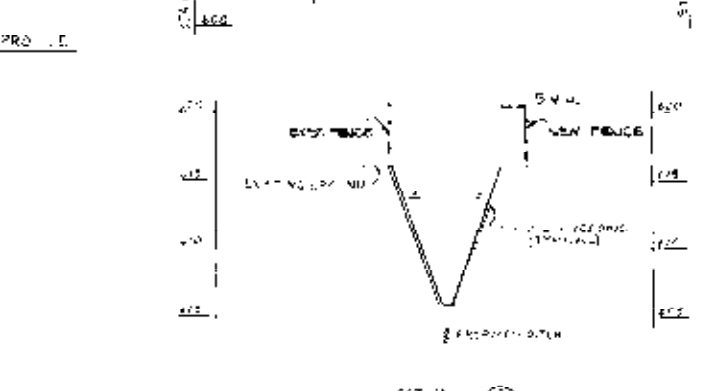
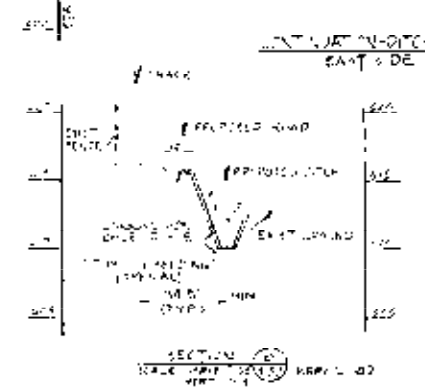
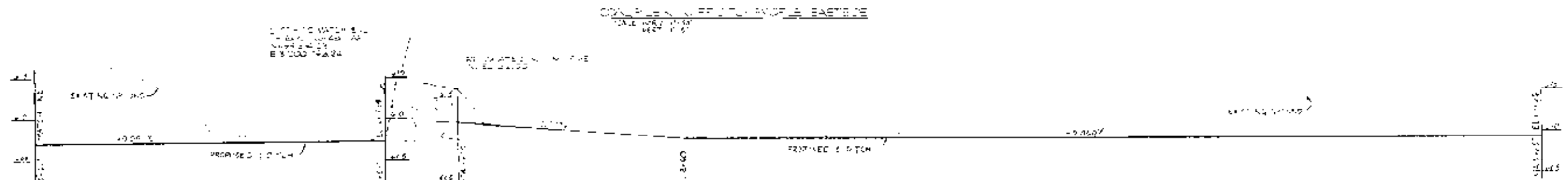
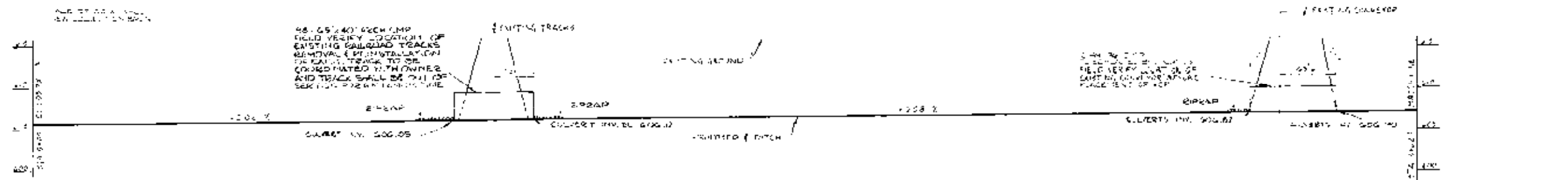

NOTE:
THE WIDTH OF BOTTOM OF DITCH IS 5.0' EXCEPT WHERE NOTED OTHERWISE.

NOTES:
1. FOR 2 TO 1 PLAN SEE DRAWING 101.4-101.4
2. FOR 4 TO 1 PLAN SEE DRAWING 101.5-101.5

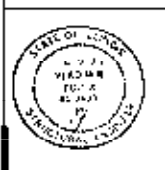

NO.	REVISIONS
1	GENERAL NOTES
2	ADD NOTES FOR CONSTRUCTION
3	ADD NOTES FOR CONSTRUCTION
4	ADD NOTES FOR CONSTRUCTION
5	ADD NOTES FOR CONSTRUCTION

NO.	REFERENCE DRAWINGS
1	GENERAL NOTES
2	ADD NOTES FOR CONSTRUCTION
3	ADD NOTES FOR CONSTRUCTION
4	ADD NOTES FOR CONSTRUCTION
5	ADD NOTES FOR CONSTRUCTION

NO.	PERMIT RECORD
1	DATE ISSUED
2	DATE OF PROJECT
3	DATE OF PROJECT
4	DATE OF PROJECT
5	DATE OF PROJECT

NO.	FIELD RECORD
1	CHECKED
2	CHECKED
3	CHECKED
4	CHECKED
5	CHECKED

NO.	DRAWING STATUS
1	DATE
2	DATE
3	DATE
4	DATE
5	DATE

SCANNED BY: []

CIVIL
MISCELLANEOUS SECTIONS & DETAILS SHEET

WASTEWATER MANAGEMENT FACILITIES
CENTRAL ILLINOIS PUBLIC SERVICE COMPANY
COFFEE POWER STATION

AS SHOWN

Stearns-Roger

DATE: 10/20/00

SCALE: 1"=20'

SHEET NO. 12-10

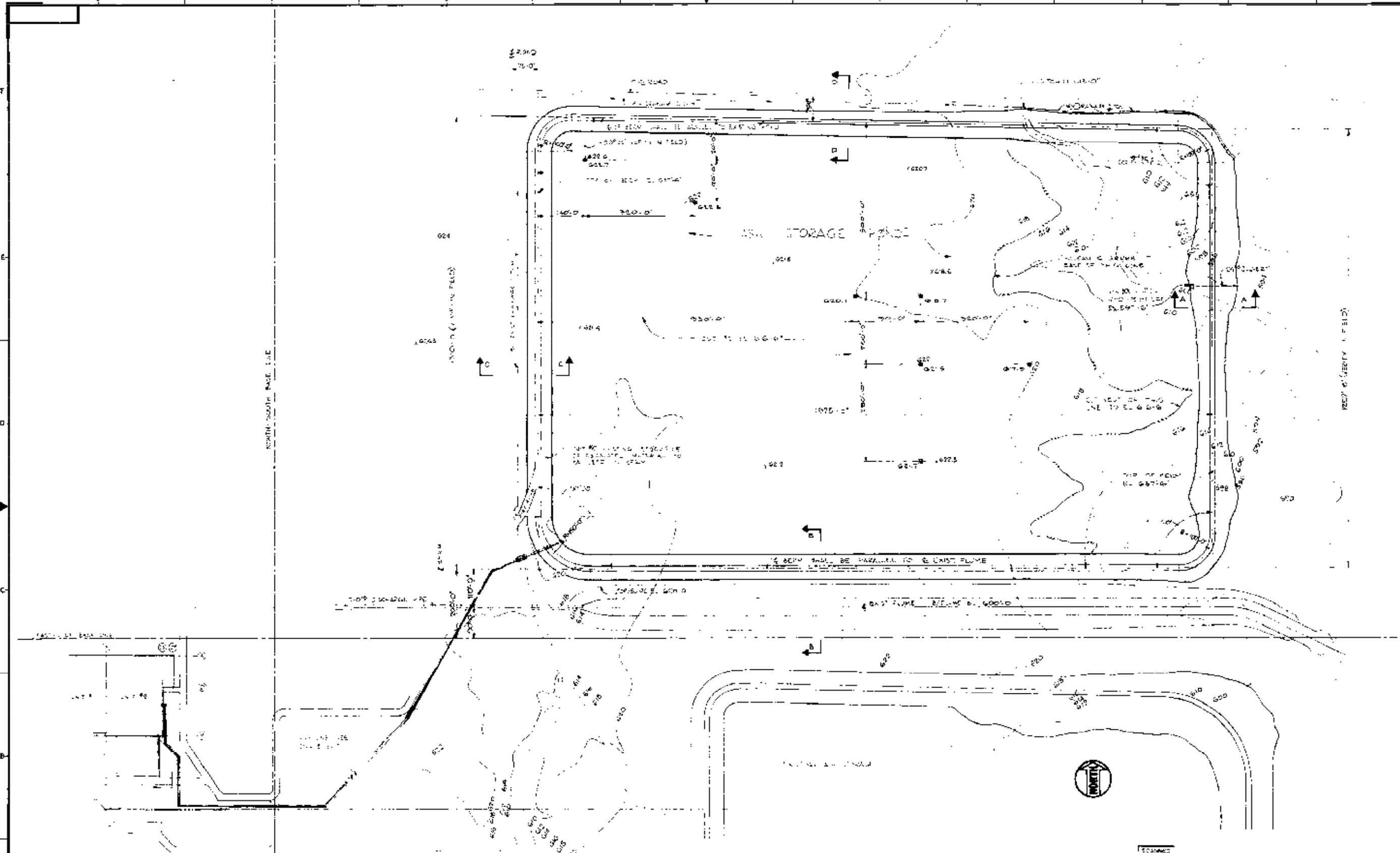

NOTES
 1 THE DISTANCE FROM THE CORNER OF THE LOT TO THE CENTERLINE OF THE ROAD IS 100.0'.
 2 THE DISTANCE FROM THE CORNER OF THE LOT TO THE CENTERLINE OF THE ROAD IS 100.0'.
 3 THE DISTANCE FROM THE CORNER OF THE LOT TO THE CENTERLINE OF THE ROAD IS 100.0'.

REFERENCE DRAWINGS

Date	Description	By	Check

ASH STORAGE AREA

PLAN

UNIT 2

COFFEEN POWER STATION

UNIT 2

CENTRAL ILL. PUBLIC SERVICE CO.

COFFEEN, ILLINOIS

SCALE: 1" = 100'-0"

DRAWN BY: J. M. HAYES

CHECKED BY: J. M. HAYES

APPROVED BY: *J. M. Hayes*

SARGENT & LUNDY

ENGINEERS

DRAWING NO. **D-560**

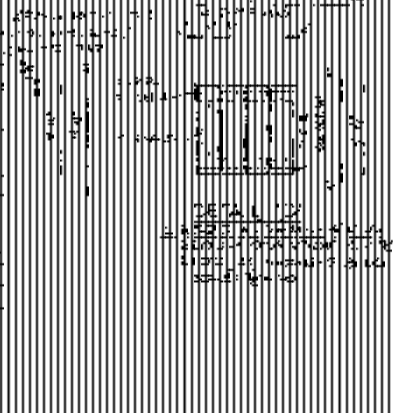
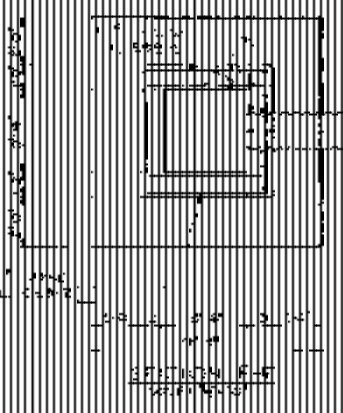
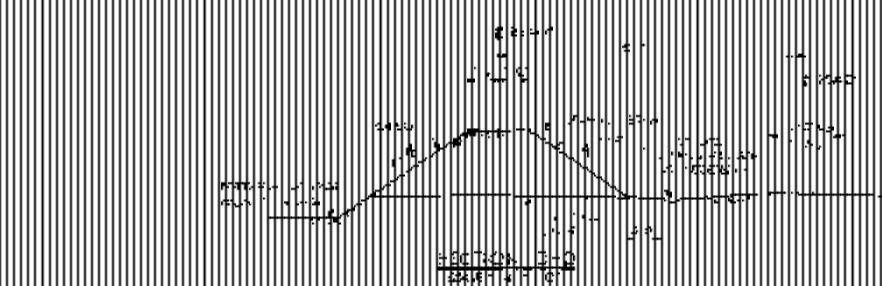
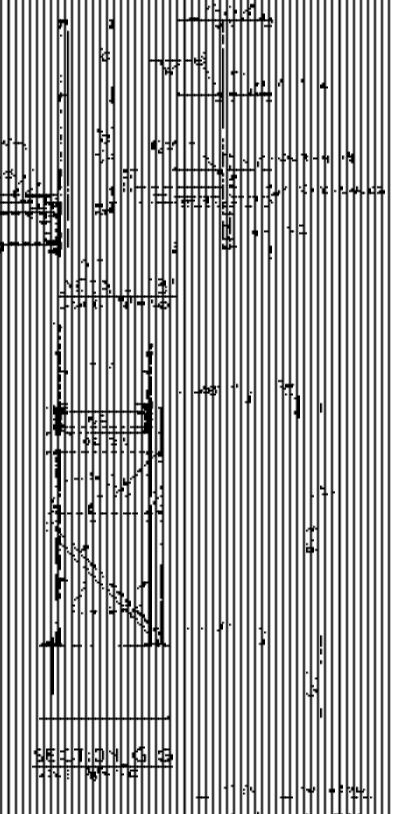
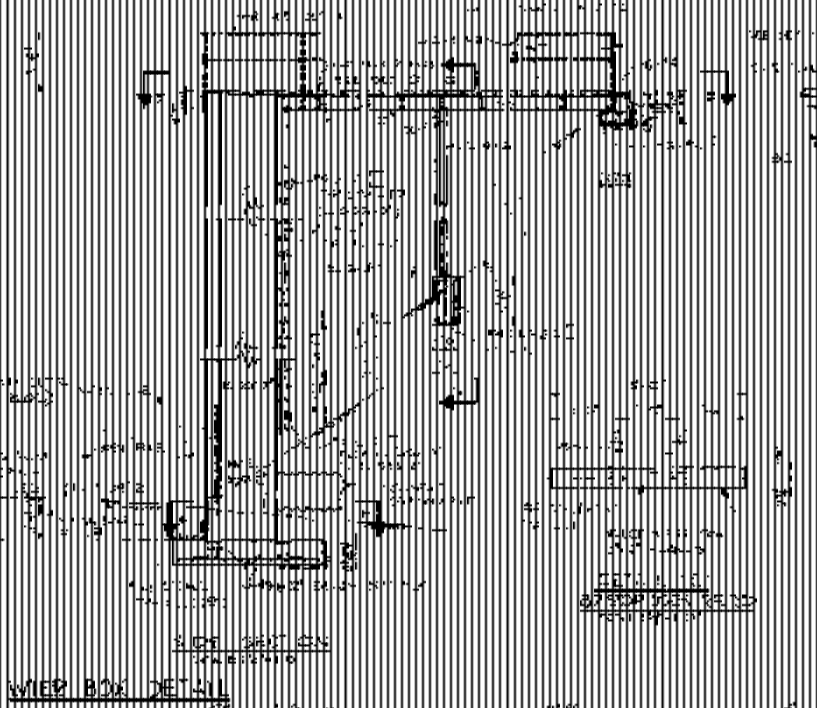
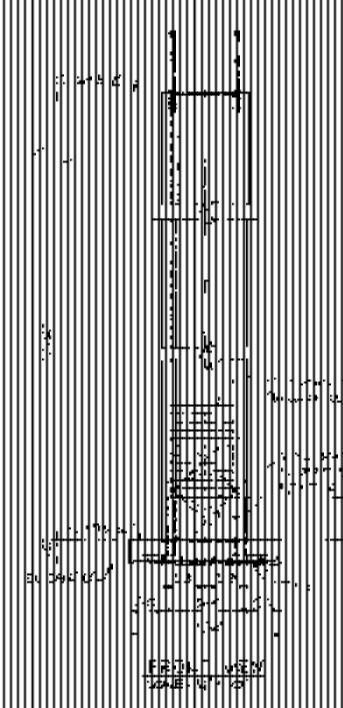
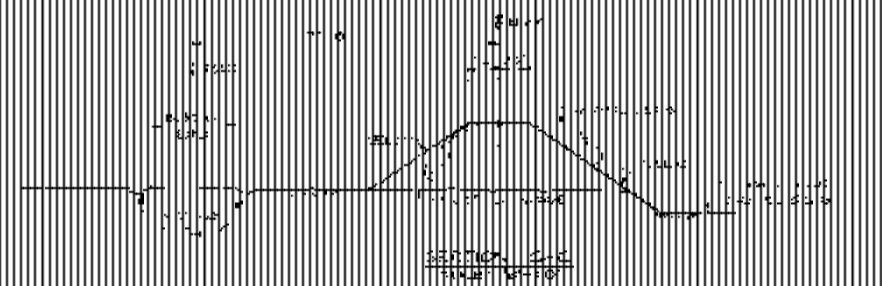
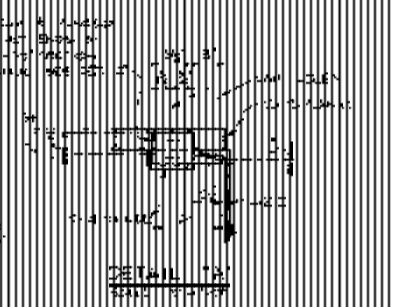
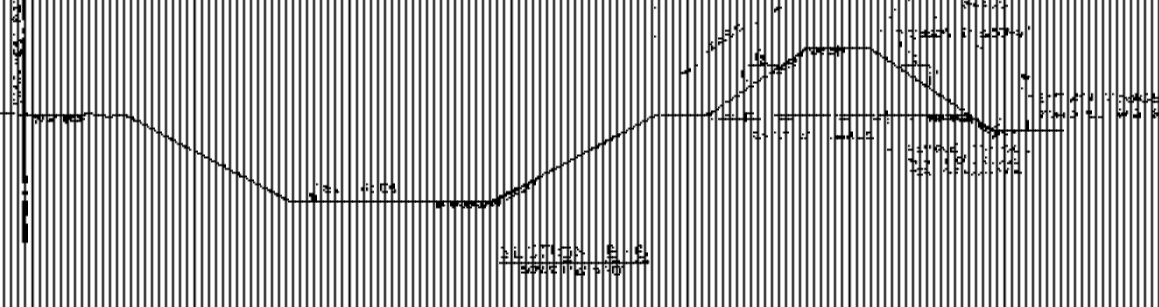
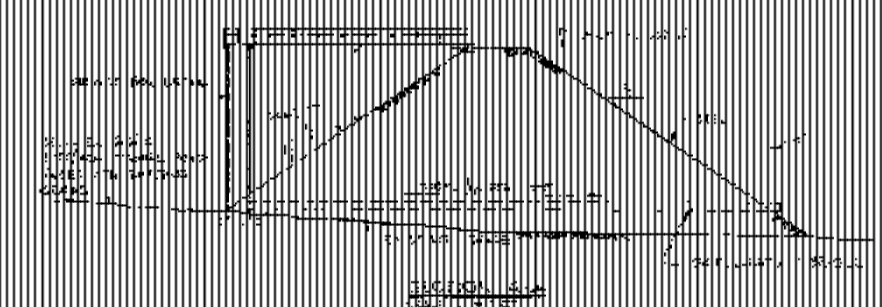

NORTH 		REFERENCE DRAWINGS SEE DRAWING NO. _____ SEE DRAWING NO. _____ SEE DRAWING NO. _____		ASH STORAGE AREA SECTIONS & DETAILS UNIT 2 COFFEE POWER STATION UNIT 2 CENTRAL ILL. PUBLIC SERVICE CO. COFFEE, ILLINOIS	
DATE _____	DRAWN BY _____	CHECKED BY _____	SCALE _____	SHEET NO. _____	TOTAL SHEETS _____
SARGENT & LUNDY ENGINEERS 100 N. WASHINGTON ST. CHICAGO, ILL. 60602			0-561		

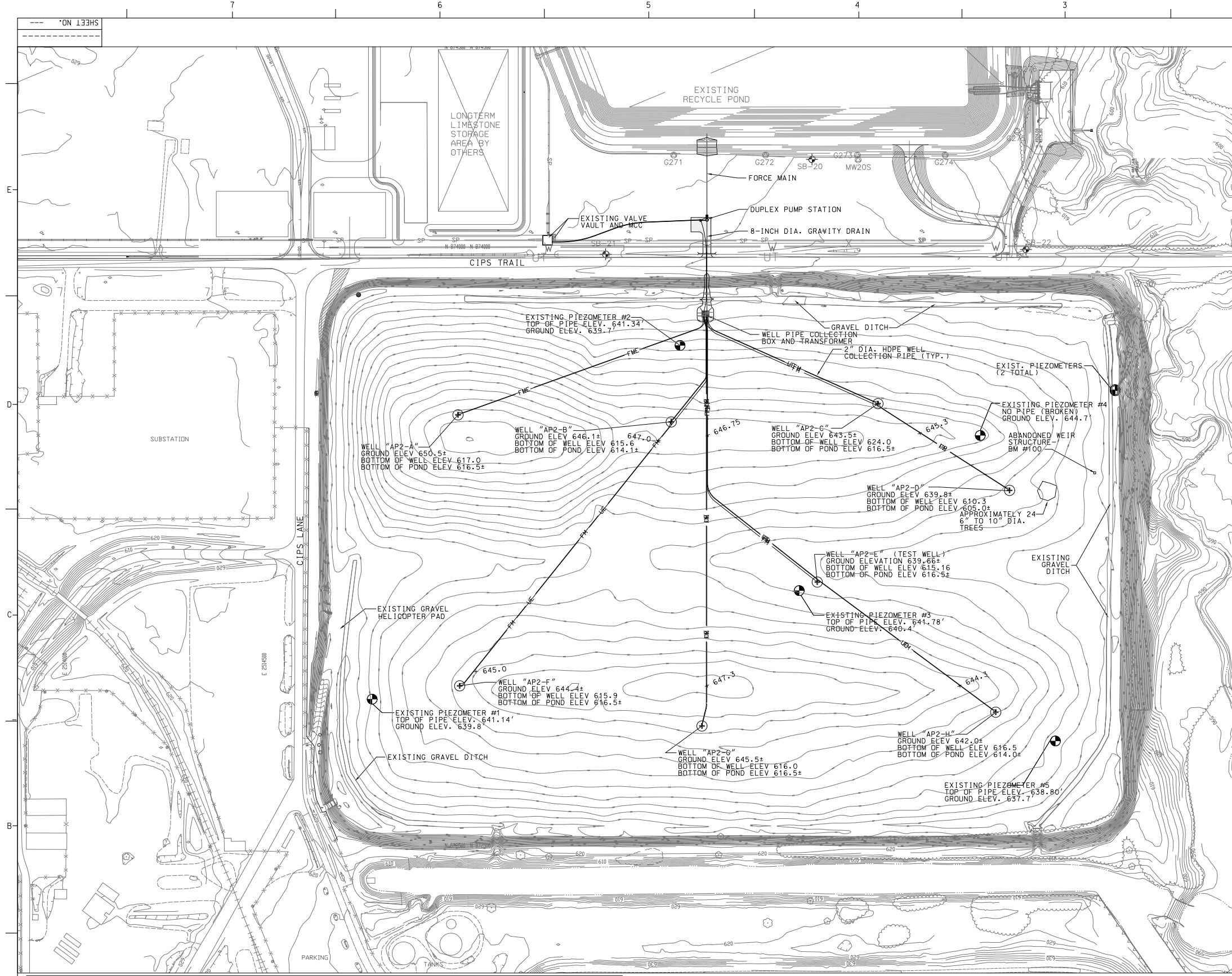

NOTES:

1. THE LOCATION, SIZE AND/OR TYPE OF MATERIAL OF EXISTING UNDERGROUND OR OVERHEAD UTILITIES AS MAY BE INDICATED ON THESE CONSTRUCTION PLANS IS NOT REPRESENTED AS BEING ACCURATE, SUFFICIENT OR COMPLETE. THE OWNER AND THE PROJECT ENGINEER HAVE NOT INDEPENDENTLY VERIFIED THIS INFORMATION AND DO NOT ASSUME ANY RESPONSIBILITY WHATSOEVER IN RESPECT TO THE ACCURACY, SUFFICIENCY OR COMPLETENESS OF THE INFORMATION AND GIVE NO EXPRESSED OR IMPLIED GUARANTEE THAT ANY CONDITIONS INDICATED ARE REPRESENTATIVE OF ACTUAL CONDITIONS TO BE ENCOUNTERED.
2. IT SHALL BE THE CONTRACTOR'S RESPONSIBILITY TO DETERMINE THE ACTUAL LOCATION OF ALL SUCH FACILITIES, INCLUDING SERVICE CONNECTIONS TO UNDERGROUND UTILITIES. PRIOR TO CONSTRUCTION, THE CONTRACTOR SHALL NOTIFY ALL UTILITY COMPANIES AND AGENCIES OF HIS CONSTRUCTION PLANS AND SHALL OBTAIN FROM EACH PARTY DETAILED INFORMATION AND ASSISTANCE RELATIVE TO THE LOCATION OF ALL UTILITIES AND THE SCHEDULE OF ANY REMOVALS AND ADJUSTMENTS REQUIRED OF THE UTILITY. THE CONTRACTOR SHALL CONTACT J.U.L.I.E. (1-800-892-0123 OR 811) TO ASSIST IN COMPLETING THIS RESPONSIBILITY.
3. THE CONTRACTOR SHALL PROTECT ANY FACILITIES TO THE SATISFACTION OF THE UTILITY OR OWNING-AGENCY WITH THE COST OF ANY REQUIRED PROTECTION TO BE INCIDENTAL TO THE CONTRACT. IN THE EVENT A UTILITY LINE OR SERVICE IS UNEXPECTEDLY ENCOUNTERED DURING CONSTRUCTION, THE CONTRACTOR SHALL IMMEDIATELY NOTIFY THE OWNER AND THE UTILITY COMPANY OR AGENCY OF JURISDICTION. ANY SUCH UTILITIES DISTURBED BY THE CONTRACTOR'S OPERATIONS SHALL BE RESTORED TO SERVICE AT ONCE.

COORDINATE TABLE

POINT	STATE PLANE COORDINATES			DESCRIPTION	PLANT COORDINATES		
	NORTH	EAST	ELEV.		NORTH	EAST	ELEV.
100	873,444.5	2,516,566.2	636.78'	BENCHMK: CHISELED "C" IN N.E. COR. OF WEIR BOX	3610.958	1357.406	616.31'
1	872,940.7900	2,513,222.5010	615.74'	CONTROL PT #1 BRASS MONUMENT NEAR N.W. ENTRANCE	3610.440	2430.490	623.44'
2	872,942.4450	2,514,295.5440	622.92'	CONTROL PT #2 BRASS MONUMENT NEAR EAST PKG AREA	4561.951	2430.945	N/A
3	873,893.9360	2,514,294.3340	624.63'	CONTROL PT #3 BRASS MONUMENT NEAR MAIN ENTRANCE			
5001	873,587.59	2,514,969.63	.	WELL AP2-A			
5002	873,569.87	2,515,503.76	.	WELL AP2-B			
5003	873,615.67	2,516,021.68	.	WELL AP2-C			
5004	873,398.41	2,516,351.29	.	WELL AP2-D			
5005	873,168.81	2,515,869.61	.	WELL AP2-E			
5006	872,908.89	2,514,973.83	.	WELL AP2-F			
5007	872,808.37	2,515,980.73	.	WELL AP2-G			
5008	872,842.91	2,516,316.70	.	WELL AP2-H			

LEGEND

- ELECTRICAL SPLICE BOX
- TELEPHONE SPLICE BOX
- GUARDPOST
- EXISTING FENCE
- TREE AREA
- GRAVEL EDGE
- PAVED OUTLET EDGE
- FM FORCE MAIN
- SS SANITARY SEWER
- UE UNDERGROUND ELECTRIC
- GRAVEL SURFACING
- PIEZOMETER
- IRON PIN

100' 50' 0 50' 100'
SCALE IN FEET

AS BUILT

**OVERALL SITE PLAN
DEWATERING SYSTEM
ASH POND #2**

AMEREN COFFEEN POWER STATION
SITE: ASH POND #2

LOC. NO.		DRAWING NO.	
CLASS		REV.	
A1000		0	
SHEET NO. 1 OF 5			

Ameren Energy
Resources
Generating

NOTICE OF LIMITED RESPONSIBILITY
THE RESPONSIBILITY OF THE UNDERSIGNED ENGINEER IS LIMITED TO THE DESIGN OF THE PROJECT AS SHOWN ON THESE PLANS. THE ENGINEER DOES NOT WARRANT THE ACCURACY OF THE INFORMATION PROVIDED BY THE CLIENT OR THE CONTRACTOR. THE ENGINEER DOES NOT WARRANT THE ACCURACY OF THE INFORMATION PROVIDED BY THE CLIENT OR THE CONTRACTOR. THE ENGINEER DOES NOT WARRANT THE ACCURACY OF THE INFORMATION PROVIDED BY THE CLIENT OR THE CONTRACTOR.

NOTES

REFERENCE DRAWINGS

REV.	DATE	PROJECT NO.	AMEREN NO.	DRAWING NO.	DESCRIPTION
A	10-12-09	#1314	SDB	SDB	MJW

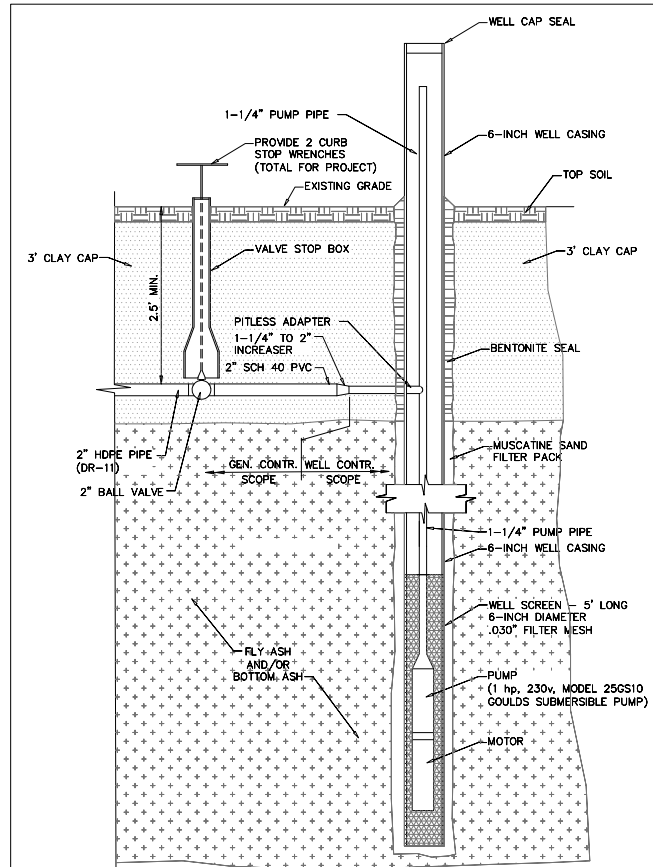

1 WELL PUMP PIPING DETAIL
NOT TO SCALE

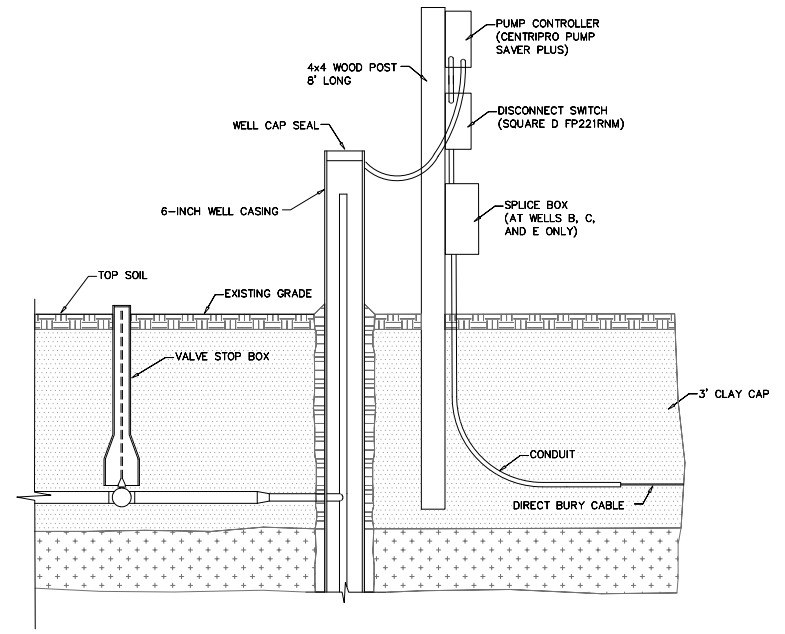

2 WELL PUMP CONTROLLER/DISCONNECT DETAIL
NOT TO SCALE

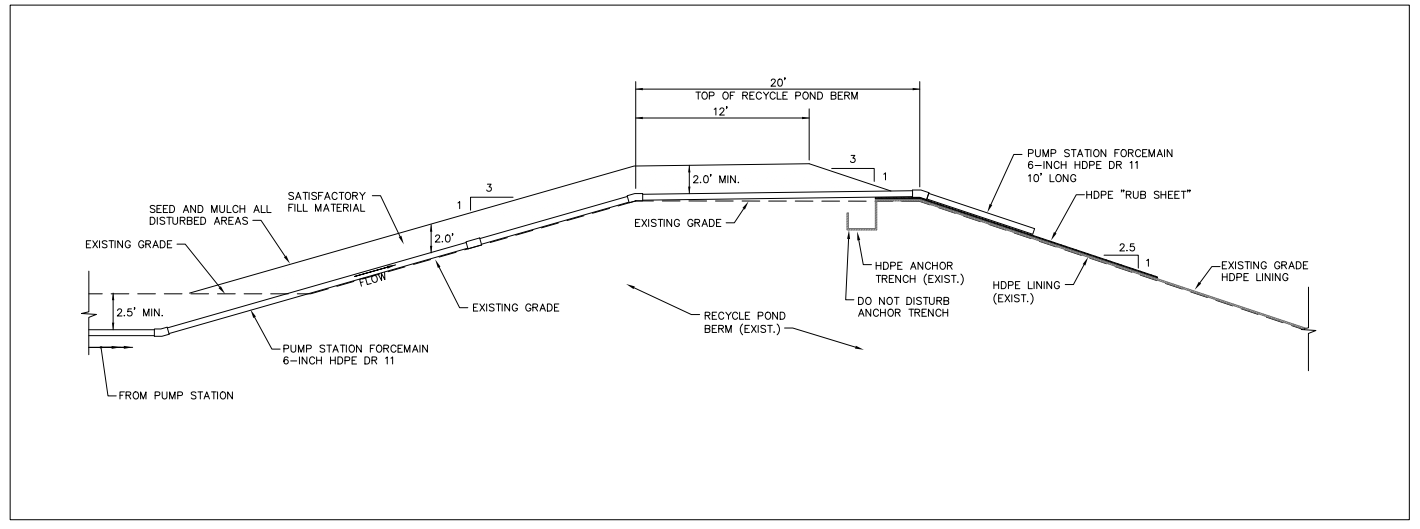

3 FORCE MAIN OUTLET DETAIL
NOT TO SCALE

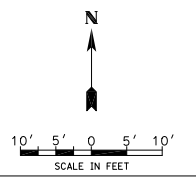

NOTES		REFERENCE DRAWINGS		DRAWING RECORD				SCALE		SITE DETAILS	
REV.	DATE	PROJECT NO.	AMEREN SUPV ENGR	DRAFTING	ENGR APPROVAL	DESCRIPTION	SCALE	SITE DETAILS		DRAWING NO.	REV.
A	10-12-09	#1314	SDB	MJW	SDB	MJW		AS BUILT		A1000	0
								SITE: ASH POND #2			
								AMEREN COFFEEN POWER STATION			
								AMEREN Energy Resources		SHEET NO. 4 OF 5	

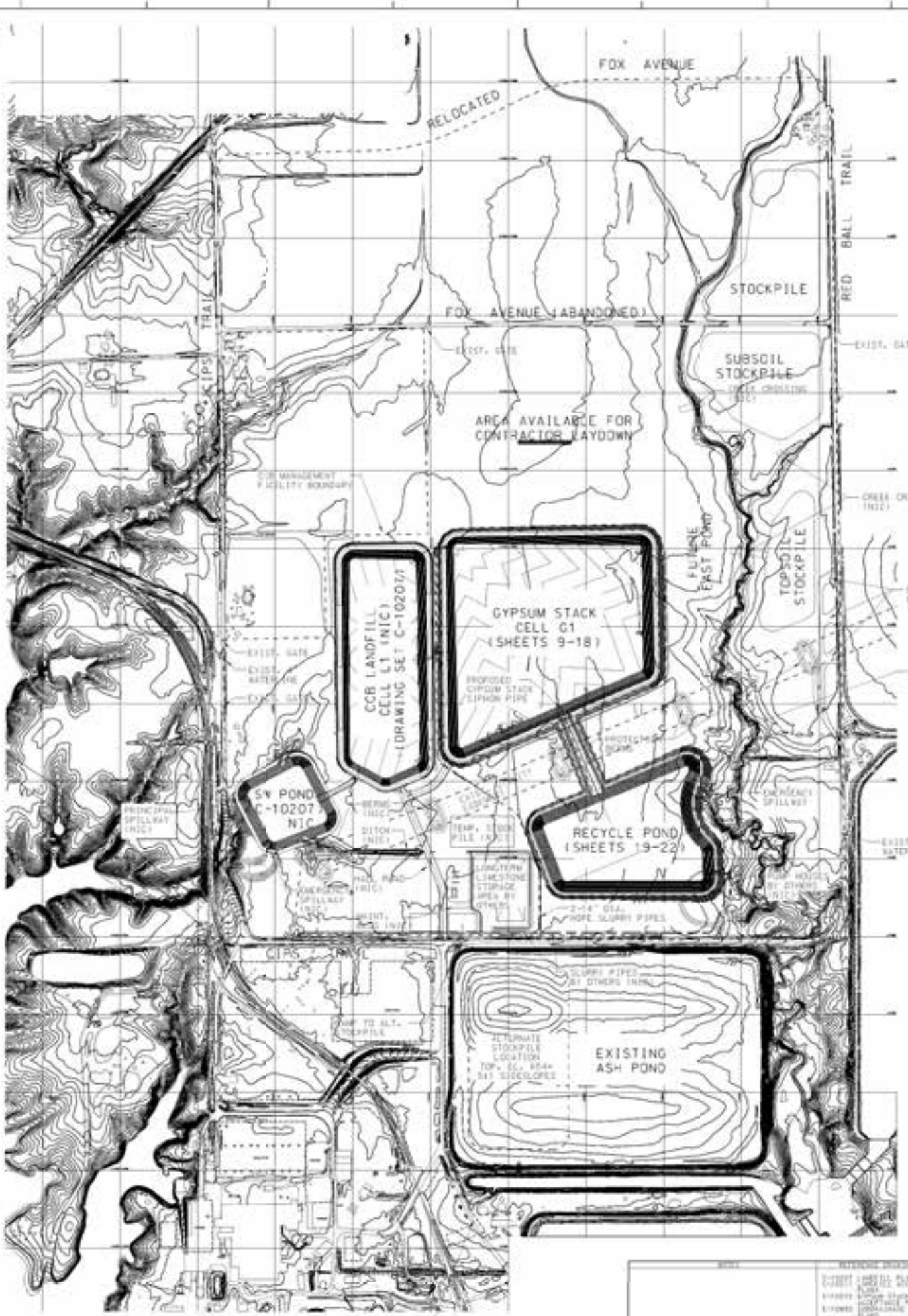

STANDARD LEGEND

- ALL SYMBOLS MAY NOT BE USED ON EACH PLAN.
- ORIGINAL CONTOURS
 - FENCELINE
 - TRANSMISSION TOWERS
 - OVERHEAD ELECTRIC
 - WATER MAIN
 - TELEPHONE LINE
 - LIMITS OF VEGETATION
 - GRAVEL ROAD
 - RAILROAD
 - CONTROL POINT - HORIZ. & VERT.
 - GEOLOGICAL CROSS SECTION LINE
 - LANDFILL CONTOURS
 - BORING
 - PREVIOUSLY INSTALLED GROUNDWATER MONITORING WELL
 - GROUNDWATER MONITORING WELL
 - WELLS - NOT PART OF MONITORING PLAN

NOTES:

1. SEE NOTES ON SHEET 2 REGARDING THE RESPONSIBILITY FOR EXISTING UTILITIES.
2. (N3E) INDICATES SITE FEATURES WHICH ARE NOT PART OF THIS CONTRACT. THEY ARE SHOWN FOR INFORMATIONAL PURPOSES ONLY.
3. HORIZONTAL AND VERTICAL CONTROL ARE BASED ON NAD 83, ILLINOIS STATE PLANE COORDINATE SYSTEM WEST ZONE, NAVD 83, 50 SURVEY FEET, AND THE FOLLOWING PROJECT CONTROL POINTS WERE ESTABLISHED BY HADSON PROFESSIONAL SERVICES:

HORIZONTAL CONTROL

POINT	NORTHING	EASTING	ELEV.	DESCRIPTION
CP-1000	873398.37	251524.17	620.81	HW REBAR 3/4" DIA. CONCRETE MONUMENT
CP-1001	873963.17	2513180.94	621.96	HW REBAR 3/4" DIA. CONCRETE MONUMENT
CP-1002	877937.74	2514555.24	623.10	HW REBAR 3/4" DIA. CONCRETE MONUMENT
CP-1003	877949.43	2514995.49	622.10	HW REBAR 3/4" DIA. CONCRETE MONUMENT



REVISIONS	REVISIONS	DESCRIPTION	

PROPOSED SITE PLAN

CCM MANAGEMENT FACILITY

LINE CORRECTION

DATE: **10/11/2011** DRAWN BY: **AS** CHECKED BY: **AS**

Amesbury CONSULTING ENGINEERS

PROJECT NO.: **C-10206** SHEET NO.: **04**

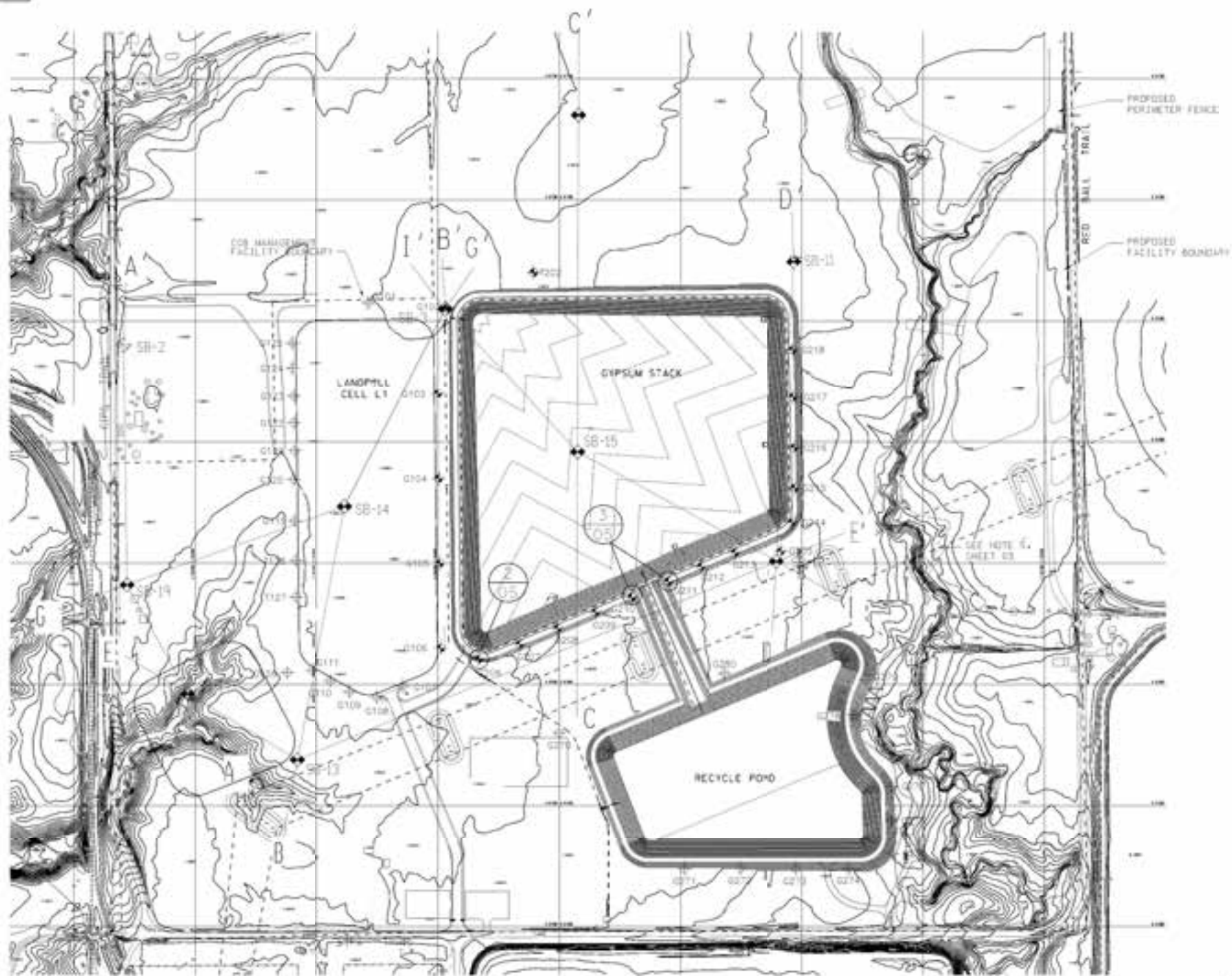

STANDARD LEGEND
 (ALL SYMBOLS MAY NOT BE USED ON EACH PLAN)

	ORIGINAL CONTOURS
	FENCELINE
	TRANSMISSION TOWER
	OVERHEAD ELECTRIC
	WATER MAIN
	TELEPHONE LINE
	LIMITS OF VEGETATION
	GRAVEL ROAD
	RAILROAD
	CONTROL POINT - HORIZ. & VERT.
	GEOLOGICAL CROSS SECTION LINE
	LINEFILL CONTOURS
	BORING
	GYPSUM STACK MONITORING WELL
	OTHER MONITORING WELL

- NOTES:**
1. CONTOURS SHOWN IN GYPSUM STACK ARE TOP OF CLAY LINER. (NOTE) THE LOWER PORTION OF THE PROCESS WATER RECOVERY SYSTEM LINER WAS ELIMINATED AS PART OF THE CLOSURE REVISIONS.
 2. THE PROPERTY IS LOCATED IN SECTIONS 10 & 11, TOWNSHIP 1 NORTH, RANGE 3 WEST, 9RD P.M., MONTGOMERY COUNTY, ILLINOIS.
 3. THE DESIGN ELEMENTS INCLUDED IN THESE DRAWINGS WERE BASED UPON EXISTING AERIAL MAPPING AS OBTAINED FROM AEREN.
 4. ALL DISTURBED AREAS, INCLUDING THE CREST AND EXTERIOR FACE OF BOTH EMBANKMENTS WILL BE SEEDDED AND MULCHED WITH 100% CLASS 1A SEED MIXTURE.
 5. FILL MATERIAL FOR DIRT EMBANKMENT WILL BE PLACED IN MAXIMUM UNCOMPACTED LIFTS OF 9-INCHES AND COMPACTED TO 95% OF THE STANDARD PROCTOR DENSITY.
 6. SURFICIAL CONTOURS WERE DEVELOPED USING AERIAL PHOTOGRAMMETRIC METHODS WITH PHOTOGRAPHS TAKEN BY SURDEX.
 7. CURRENT SURFACE TOPOGRAPHY MAY DIFFER FROM THAT SHOWN DUE TO ON GOING OPERATIONS AT THE SITE.
 8. FOR CLARITY, NOT ALL EXISTING SITE FEATURES ARE SHOWN IN THIS DRAWING.

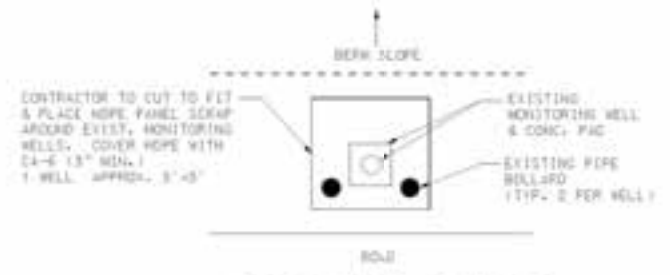

1
05
WEED CONTROL AT EXIST. SINGLE MONITORING WELLS

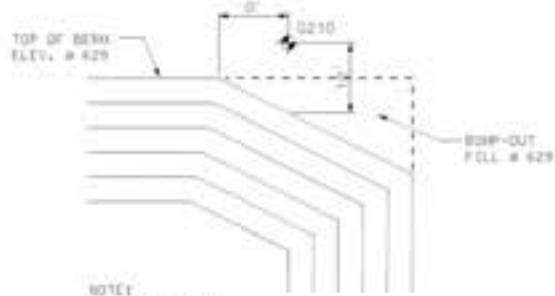

3
05
MONITORING WELL BUMP-OUT NEAR TRANSFER CHANNEL



2
05
MONITORING WELL BUMP-OUT AT HAUL ROAD

NO.	REVISIONS	DATE	BY	CHKD.	DESCRIPTION

WELLS & BORING MONITORING PLAN
 CFB MANAGEMENT FACILITY
 01/24/2008
 SHEET 05 OF 08

AMERICAN LEADERS
 CONSULTING ENGINEERS

SCALE: 1" = 200'

90201-3

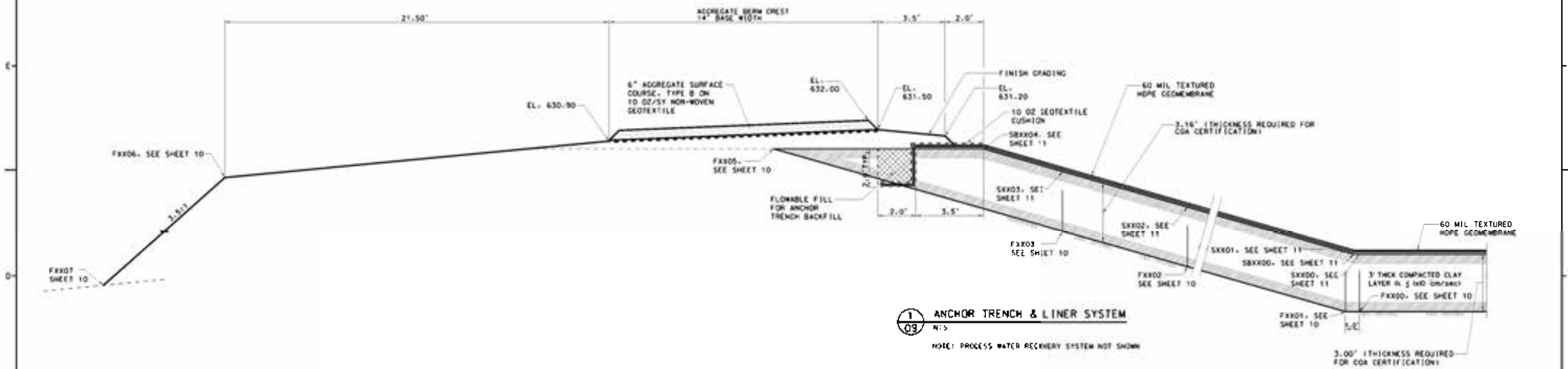

1
ANCHOR TRENCH & LINER SYSTEM
N:5

NOTE: PROCESS WATER RECOVERY SYSTEM NOT SHOWN

REVISIONS

NO.	DESCRIPTION	DATE	BY	CHKD.	APP. AUTHORITY	DESCRIPTION
1	AS SHOWN					

ANCHOR TRENCH AND LINER SYSTEM	
PCW MANAGEMENT FACILITY	
URS CORP.	
DATE: 12/10/08	SCALE: 1"=10'
PROJECT: C-10206	SHEET NO: 10

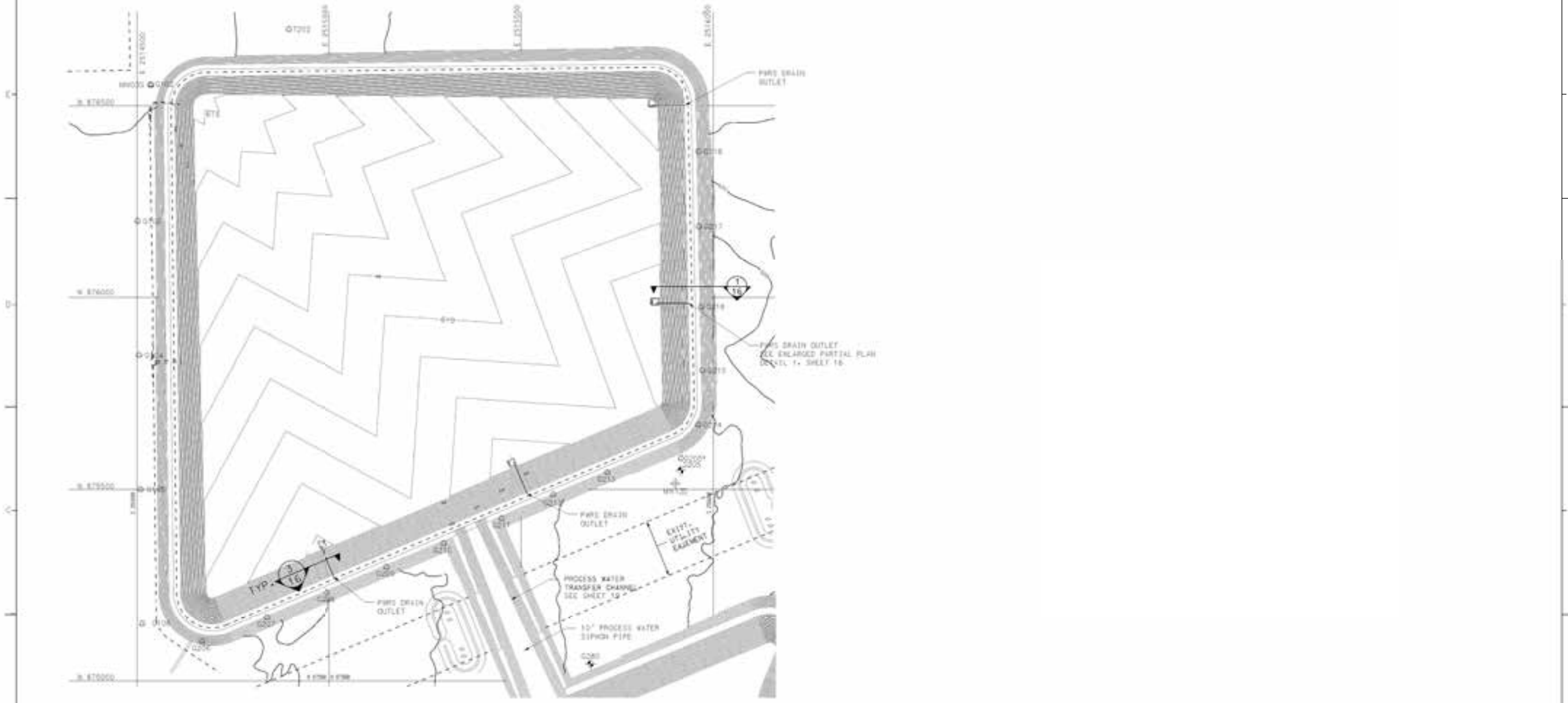

<p>REVISIONS</p> <table border="1"> <thead> <tr> <th>NO.</th> <th>DATE</th> <th>DESCRIPTION</th> </tr> </thead> <tbody> <tr> <td> </td> <td> </td> <td> </td> </tr> <tr> <td> </td> <td> </td> <td> </td> </tr> <tr> <td> </td> <td> </td> <td> </td> </tr> <tr> <td> </td> <td> </td> <td> </td> </tr> <tr> <td> </td> <td> </td> <td> </td> </tr> </tbody> </table>										NO.	DATE	DESCRIPTION																<p>PROJECT: CELL 01-PROCESS WATER RECOVERY SYSTEM</p> <p>DATE: 08/20/2014</p> <p>SCALE: 1" = 100'</p>	
NO.	DATE	DESCRIPTION																											
<p>CELL 01-PROCESS WATER RECOVERY SYSTEM</p> <p>DATE: 08/20/2014</p> <p>SCALE: 1" = 100'</p>																													

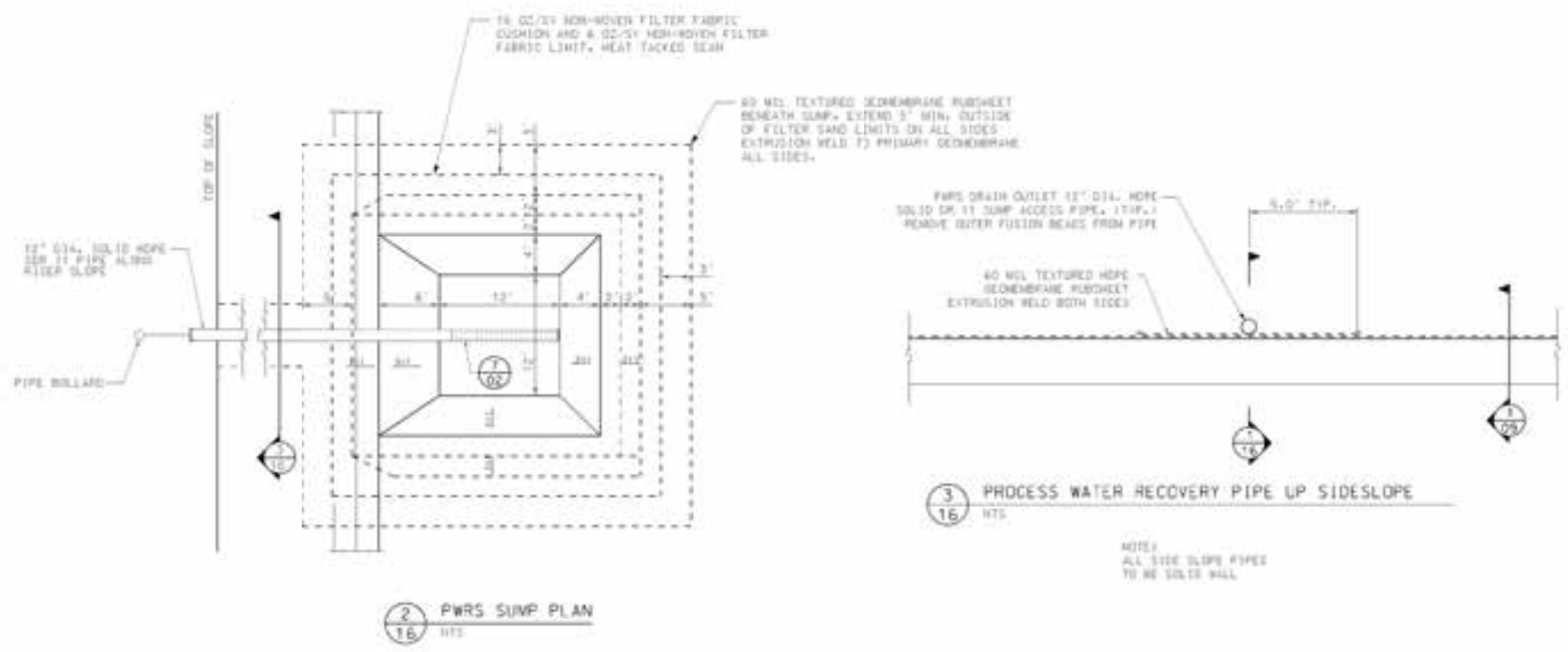
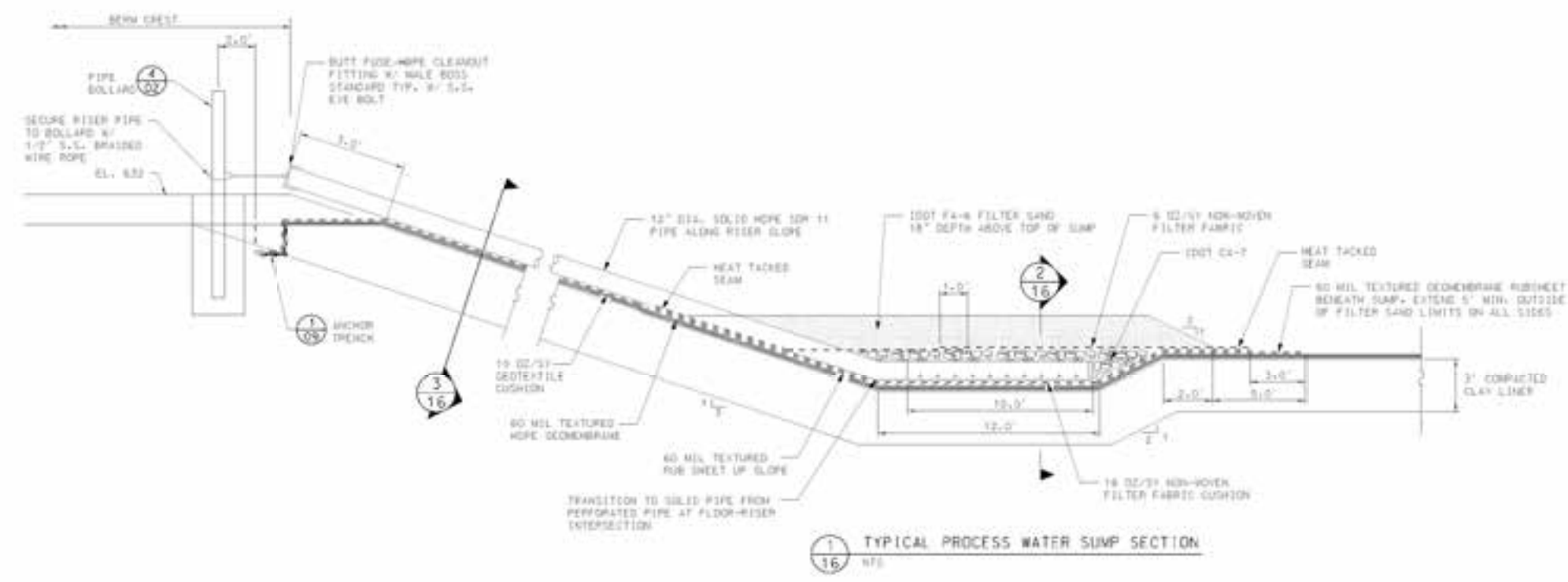

WELLS & LINES DEMONSTRATED
BY FIELD SURVEY AND/OR
EXISTING RECORDS. THE
LOCATION OF ANY UNDETECTABLE
WELLS OR LINES IS NOT
GUARANTEED BY THE
PROVIDER OF SUCH INFORMATION.

NO.	REVISION	DATE	BY	CHKD.	DESCRIPTION
1	ISSUED FOR PERMIT	08/13/20
2
3

CELL 01-PWS DRAIN DETAILS
PWS MANAGEMENT FACILITY
URS CORP.

DATE: 08/13/20
DRAWN BY: C-10206
CHECKED BY: ...

American Energy
General Contractor

90201-3

GYPHUM STACK CELL G1

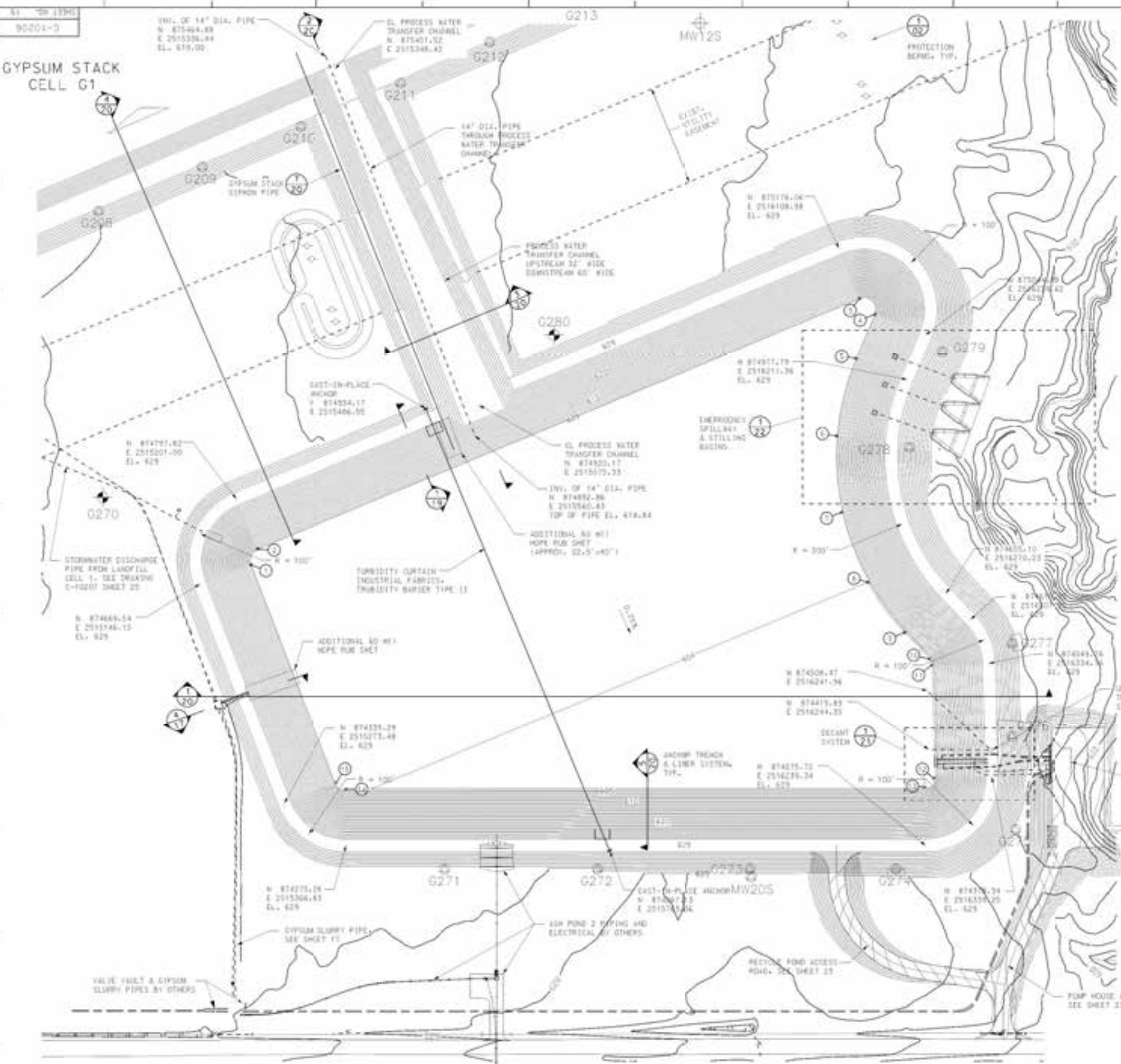

RECYCLE POND - INTERIOR TOE

POINT	N	E	ELEV.
1	874708.91	2515221.14	800.24
2	874725.71	2515241.70	800.00
3	875089.87	2516132.29	800.00
4	875089.25	2516135.88	804.50
5	875005.90	2516132.91	804.88
6	874928.21	2516101.54	804.91
7	874871.87	2516106.37	804.88
8	874717.50	2516125.93	804.29
9	874633.41	2516175.81	804.17
10	874558.24	2516246.12	804.22
11	874549.81	2516249.01	804.07
12	874577.99	2516248.77	802.44
13	874561.11	2516237.08	804.00
14	874559.91	2515566.81	804.25
15	874712.61	2515551.72	804.49

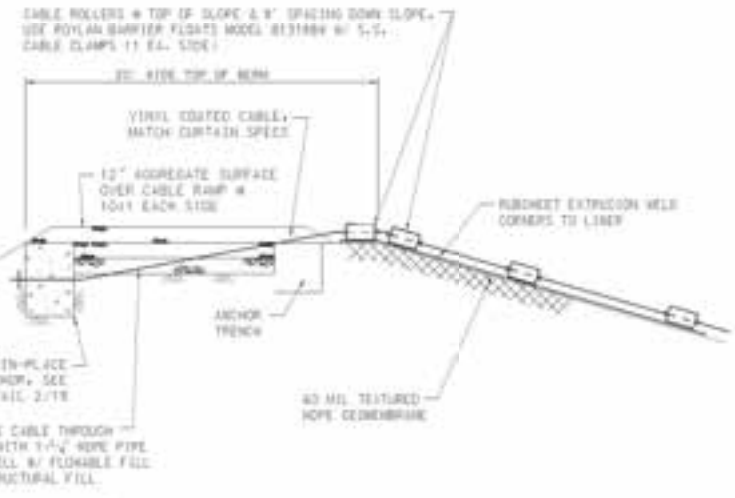

1 TURBIDITY CURTAIN ANCHOR/CONNECTION

NOTE: ALL CABLE CONNECTIONS SHALL BE 218 S.S. 437V A STRENGTH RATING GREATER THAN CABLE.

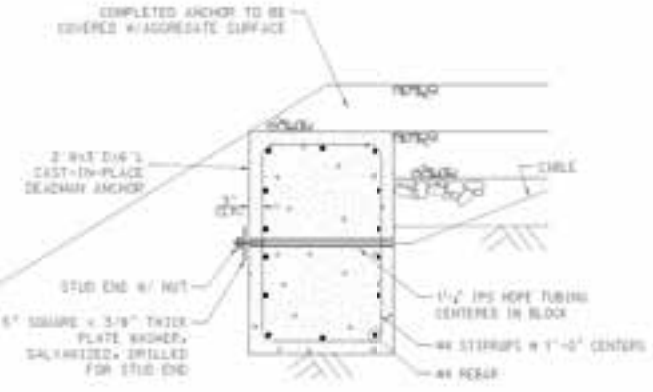

2 CAST-IN-PLACE ANCHOR

NO.	REVISION	DATE	BY	CHKD.	DESCRIPTION

PROJECT: RECYCLE POND PLAN & CONTROL DATA	
CLIENT: CCM MANAGEMENT FACILITY	
DRAWN: [Name]	
DATE: [Date]	SCALE: [Scale]
SHEET NO. 18	

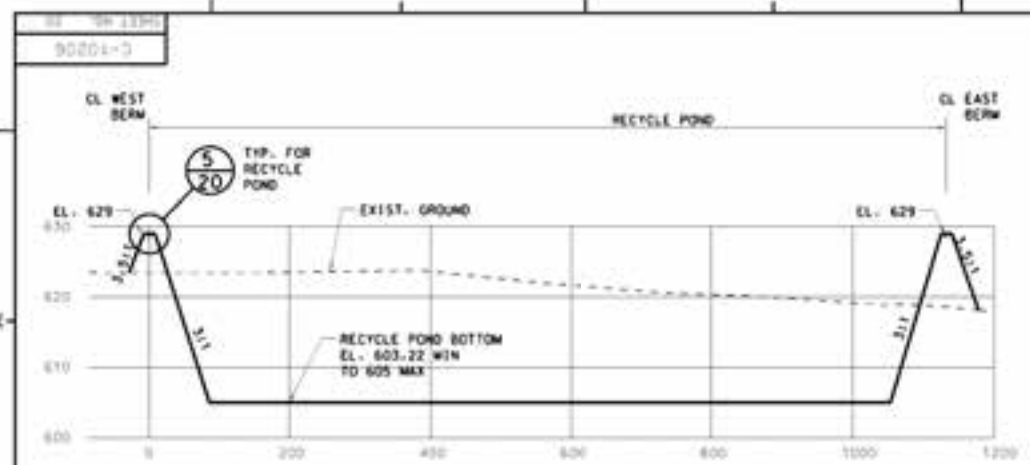

1 TYPICAL SECTION THROUGH RECYCLE POND
NTS

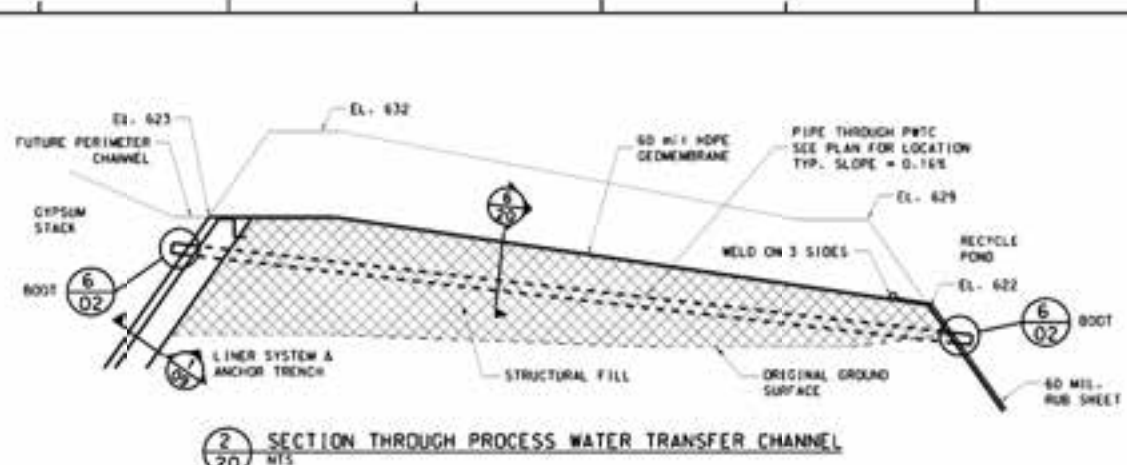

2 SECTION THROUGH PROCESS WATER TRANSFER CHANNEL
NTS

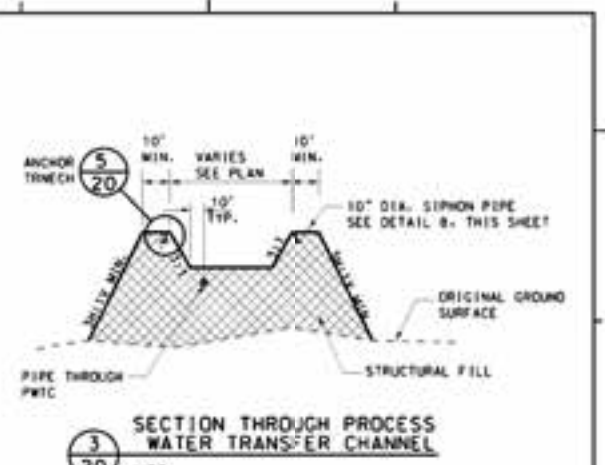

3 SECTION THROUGH PROCESS WATER TRANSFER CHANNEL
NTS

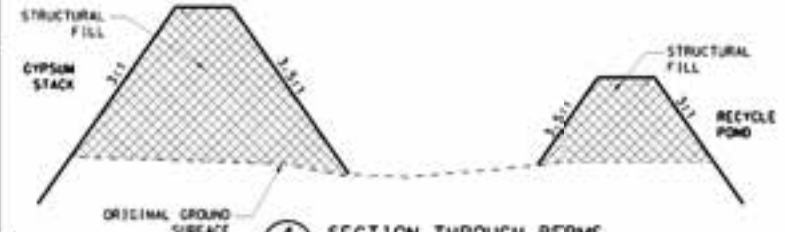

4 SECTION THROUGH BERMS
NTS

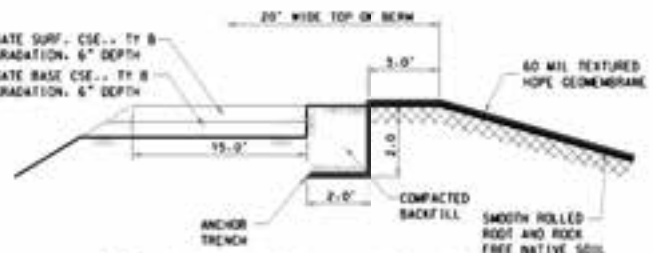

5 RECYCLE POND - LINER SYSTEM
NTS

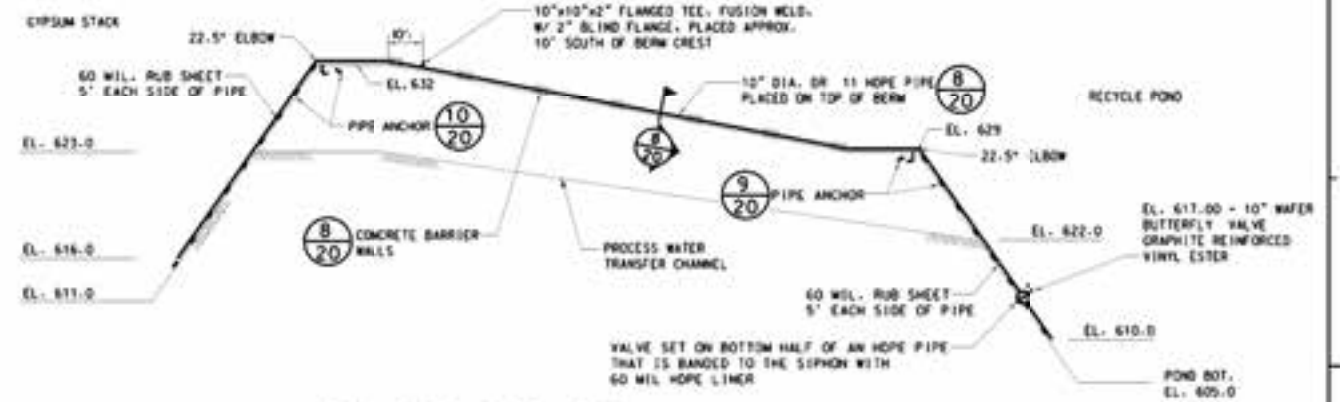

7 GYPSUM STACK SIPHON SYSTEM SECTION THROUGH PROCESS WATER TRANSFER CHANNEL
NTS

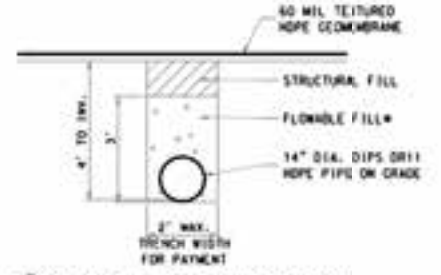

6 TYPICAL TRENCH SECTION
NTS

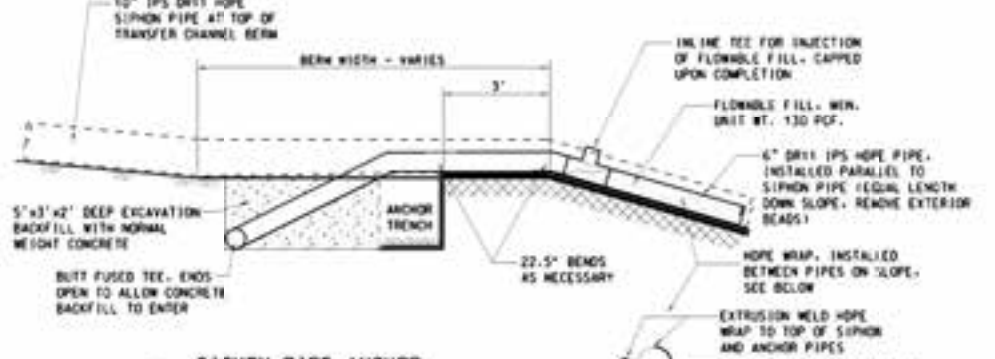

9 SIPHON PIPE ANCHOR AT RECYCLE POND BERM SECTION - NTS



8 SIPHON PIPE INSTALLATION SECTION - NTS

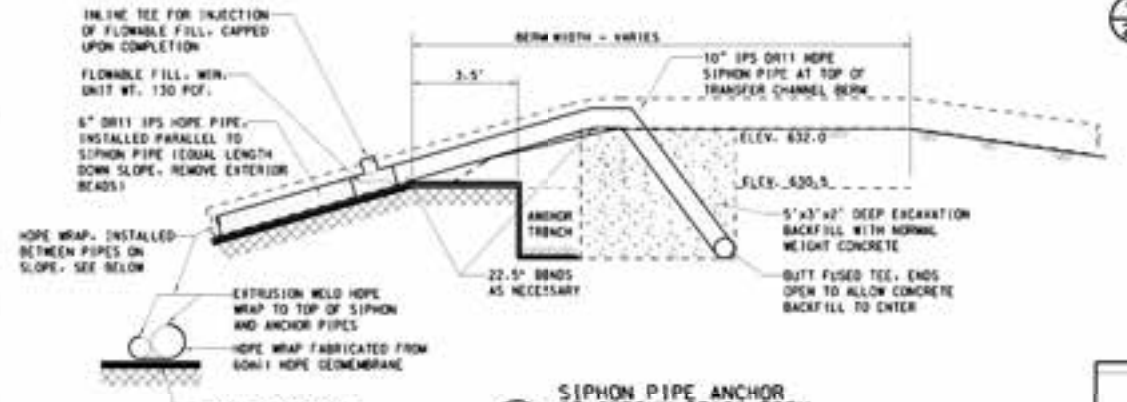

10 SIPHON PIPE ANCHOR AT GYPSUM STACK BERM SECTION - NTS

NO.	DESCRIPTION	DATE	BY	CHECKED	APPROVED	STATUS

PROJECT: RECYCLE POND - PROCESS WATER TRANSFER CHANNEL DETAILS

CLIENT: PCW MANAGEMENT FACILITY

DATE: 08/20/20

SCALE: AS SHOWN

PROJECT NO: C-10204

DRAWING NO: 0

AMERICAN ENERGY SERVICES
A Division of American Energy Services Group

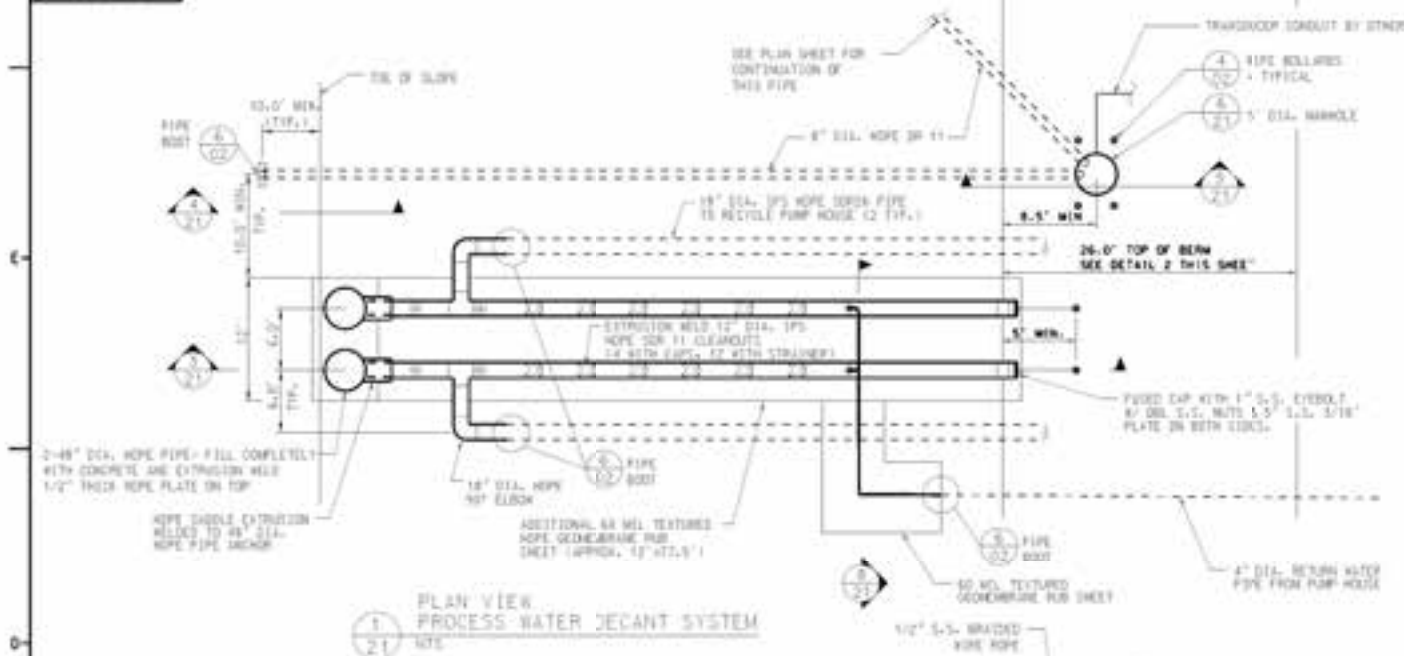

1 **PLAN VIEW
PROCESS WATER DECANT SYSTEM**
N.T.S.

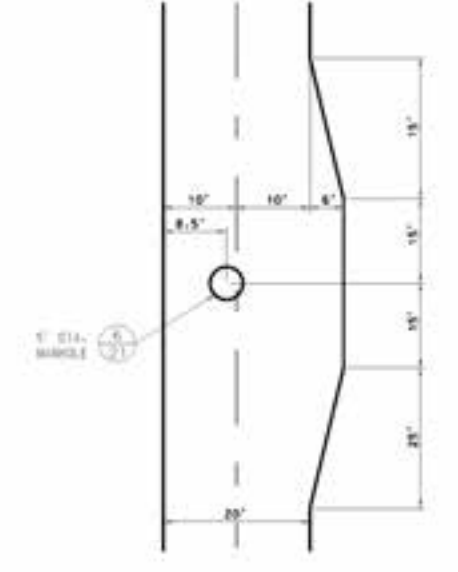

2 **BERM WIDENING AT MANHOLE**
N.T.S.

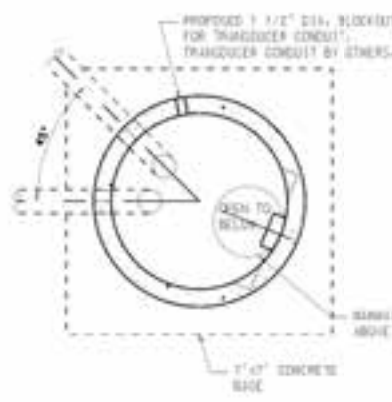

6 **MANHOLE PLAN**
N.T.S.

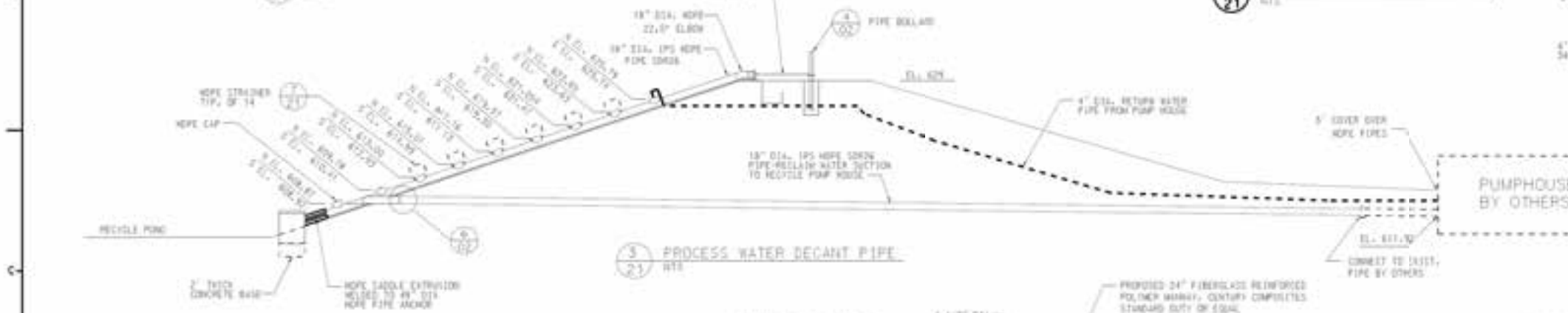

3 **PROCESS WATER DECANT PIPE**
N.T.S.

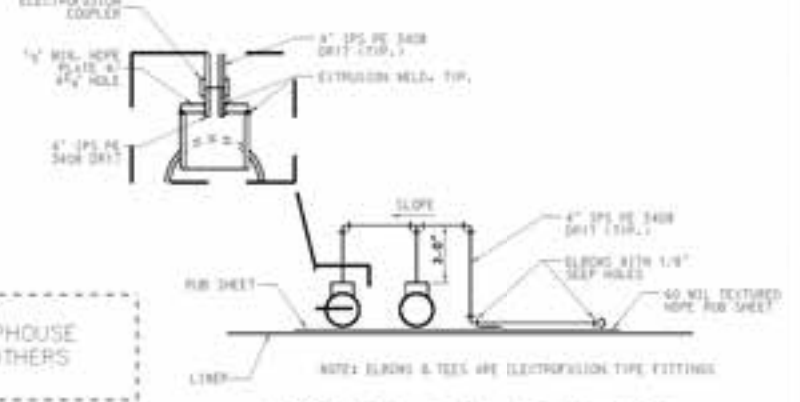

8 **RECIRCULATING LINE CONNECTION**
N.T.S.

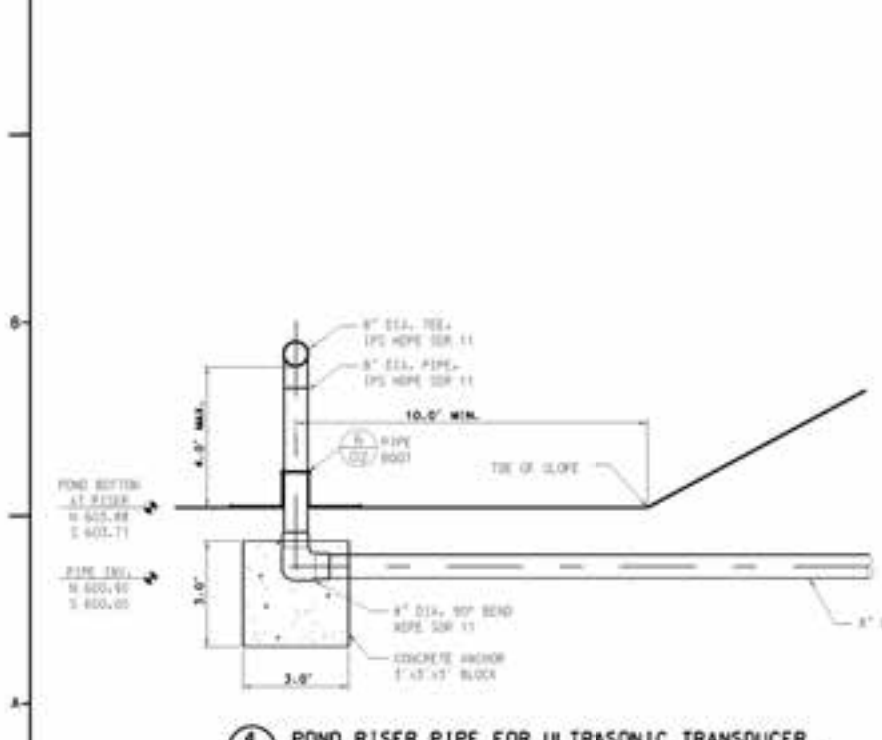

4 **POND RISER PIPE FOR ULTRASONIC TRANSDUCER**
N.T.S.

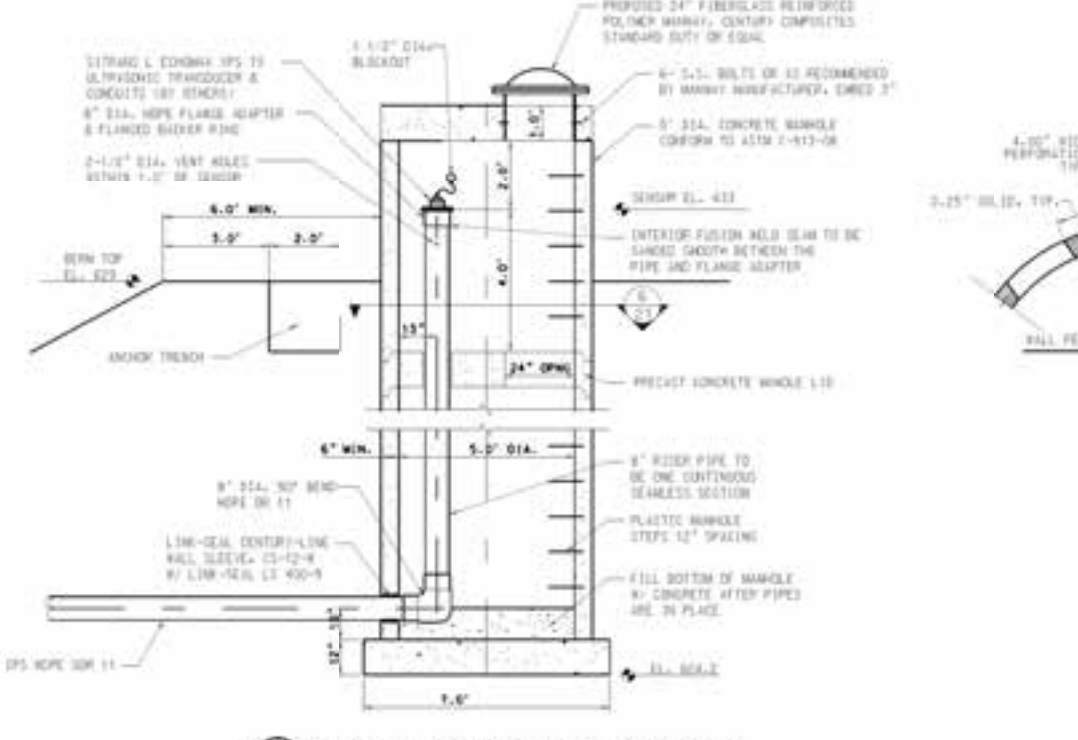

5 **MANHOLE FOR ULTRASONIC TRANSDUCER**
N.T.S.

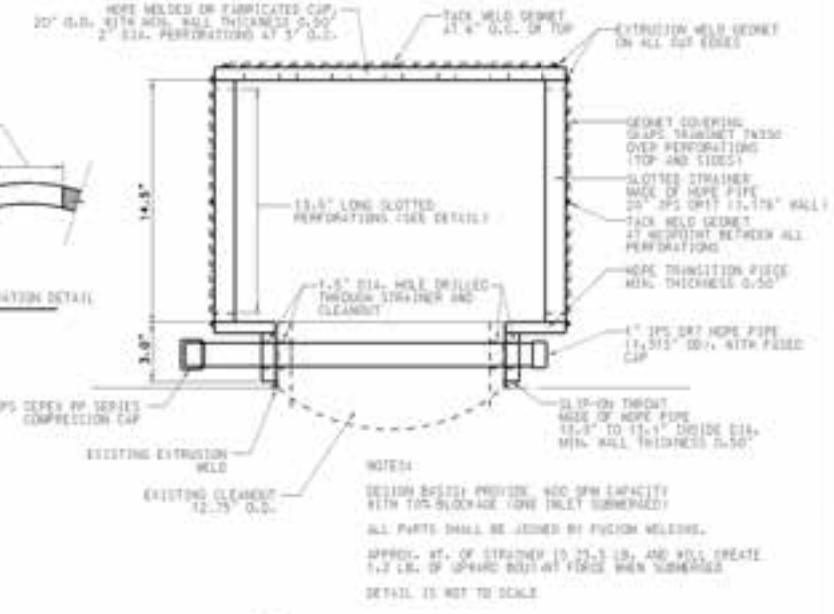

7 **HPDE STRAINER DETAIL**
N.T.S.

NO.	REVISIONS	DATE	BY	CHKD.	DESCRIPTION
1	ISSUED				
2	REVISED				
3	REVISED				
4	REVISED				

RECYCLE POND - PROCESS WATER
DECANT SECTIONS & DETAILS

PCW MANAGEMENT FACILITY

REVISED 06/03/08

C-1020W



1 STILLING BASIN PLAN AT EMERGENCY SPILLWAY
NTS

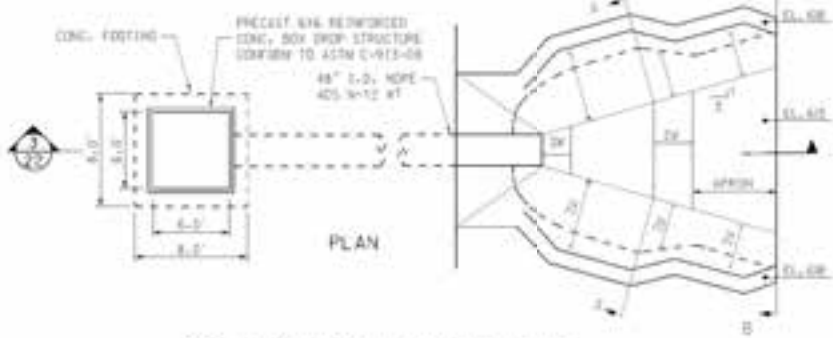

2 RIPRAP STILLING BASIN PLAN
NTS

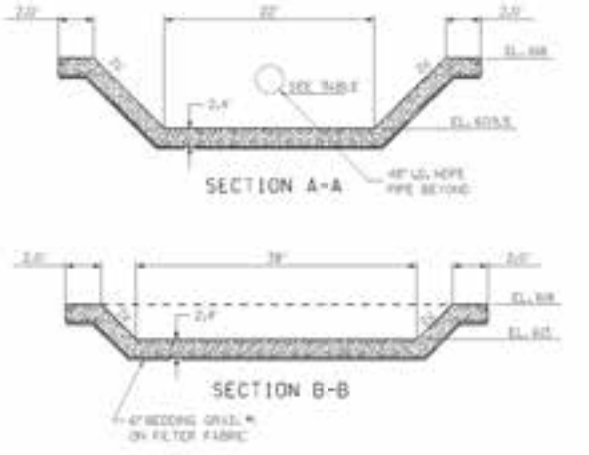

3 RIPRAP STILLING BASIN SECTION
NTS

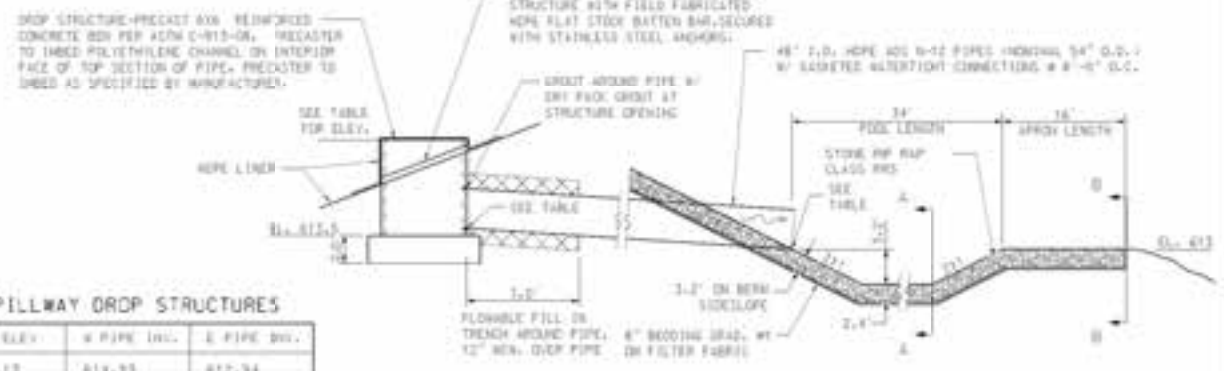

EMERGENCY SPILLWAY DROP STRUCTURES

STRUCTURE	TYP. ELEV.	W PIPE INCH.	L PIPE FEET.
NORTH	824.12	814.95	812.34
MIDDLE	824.15	814.95	813.00
SOUTH	824.11	814.03	813.06

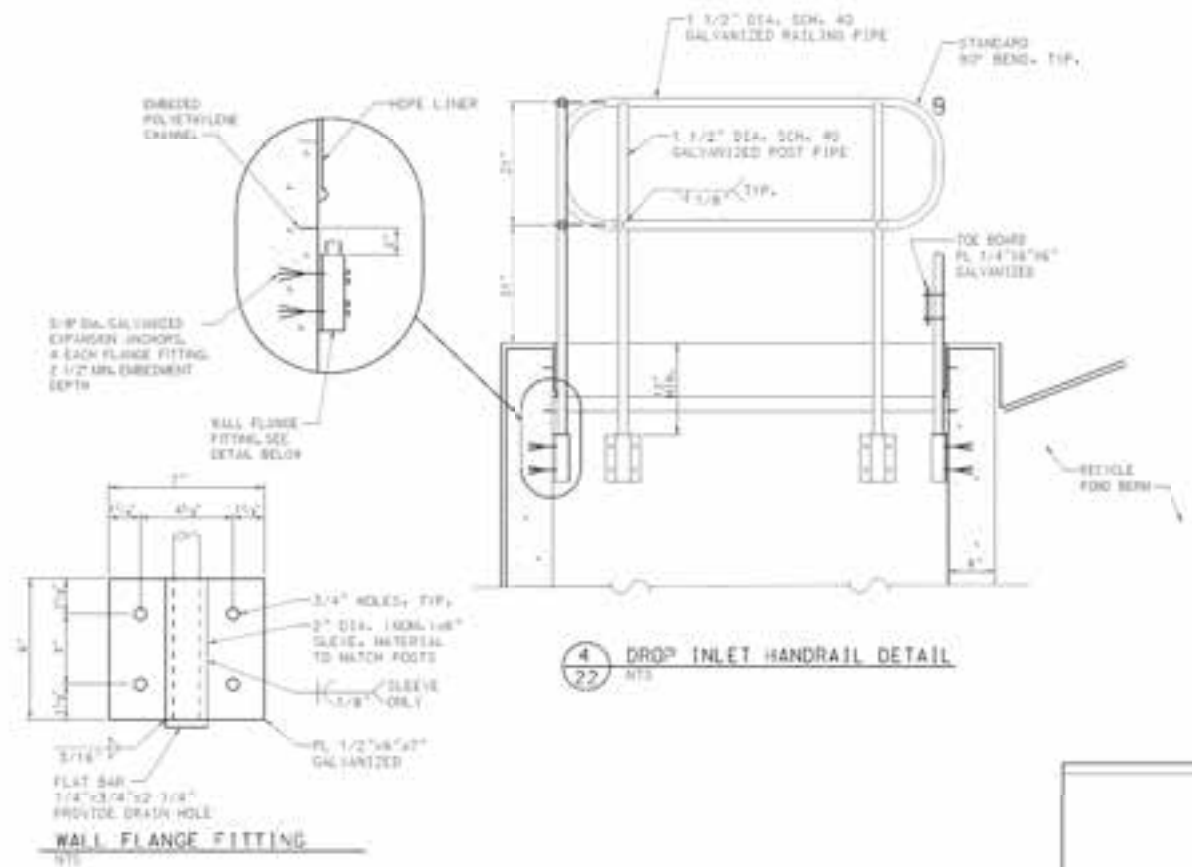

4 DROP INLET HANDRAIL DETAIL
NTS

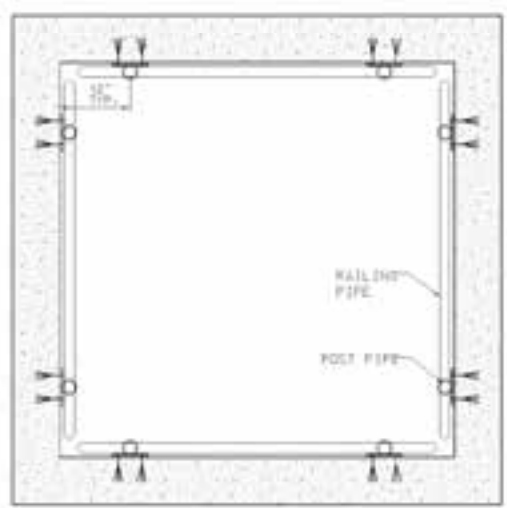

5 DROP INLET HANDRAIL PLAN
NTS

HANDRAIL NOTES

- HT-1 WELD ALL INTERSECTIONS OF RAILS AND POSTS, WELD JOINTS, AND GRIND SMOOTH TO A PLEASING APPEARANCE, TAKING CARE TO NOT REMOVE EXCESSIVE AMOUNT OF WELDED MATERIALS.
- HT-2 BUTT WELD END-TO-END JOINTS, OR USE WELDING CONNECTIONS.
- HT-3 CLEAN WELDED AREAS USING A RIFE BRUSH TO REMOVE SLAG AND LOOSE PARTICULATE, RIFE BRUSH DUST WITH A CLEAN DRY RAG AND CLEAN THE WELDED SURFACE IN ACCORDANCE WITH SSPC-SP 11.
- HT-4 TREAT ALL WELD ZONES WITH TWO COATS OF COLD GALVANIZING COMPOUND.
- HT-5 COAT THE WELDED HANDRAIL ASSEMBLY PER THE FOLLOWING:
 - 1 - 4 MIL COAT OF KYLON INDUSTRIAL GALVANIZED METAL PRIMER
 - 2 - 3 MIL COATS OF KYLON INDUSTRIAL RUST TONER DTM ALK-ID ENAMEL - COLOR: OMSA SAFETY YELLOW

NO.	REVISIONS	DATE	BY	CHKD.	DESCRIPTION
1	ISSUED FOR PERMIT	02/28/23
2
3
4
5

PROJECT	RECYCLE POND - EMERGENCY SPILLWAY SECTIONS & DETAILS
CLIENT	PCW MANAGEMENT FACILITY
DATE	02/28/23
DRAWN BY	...
CHECKED BY	...
SCALE	AS SHOWN
PROJECT NO.	C-10204
SHEET NO.	02

COFFEEN POWER STATION CLOSED ASH POND TOPO SURVEY

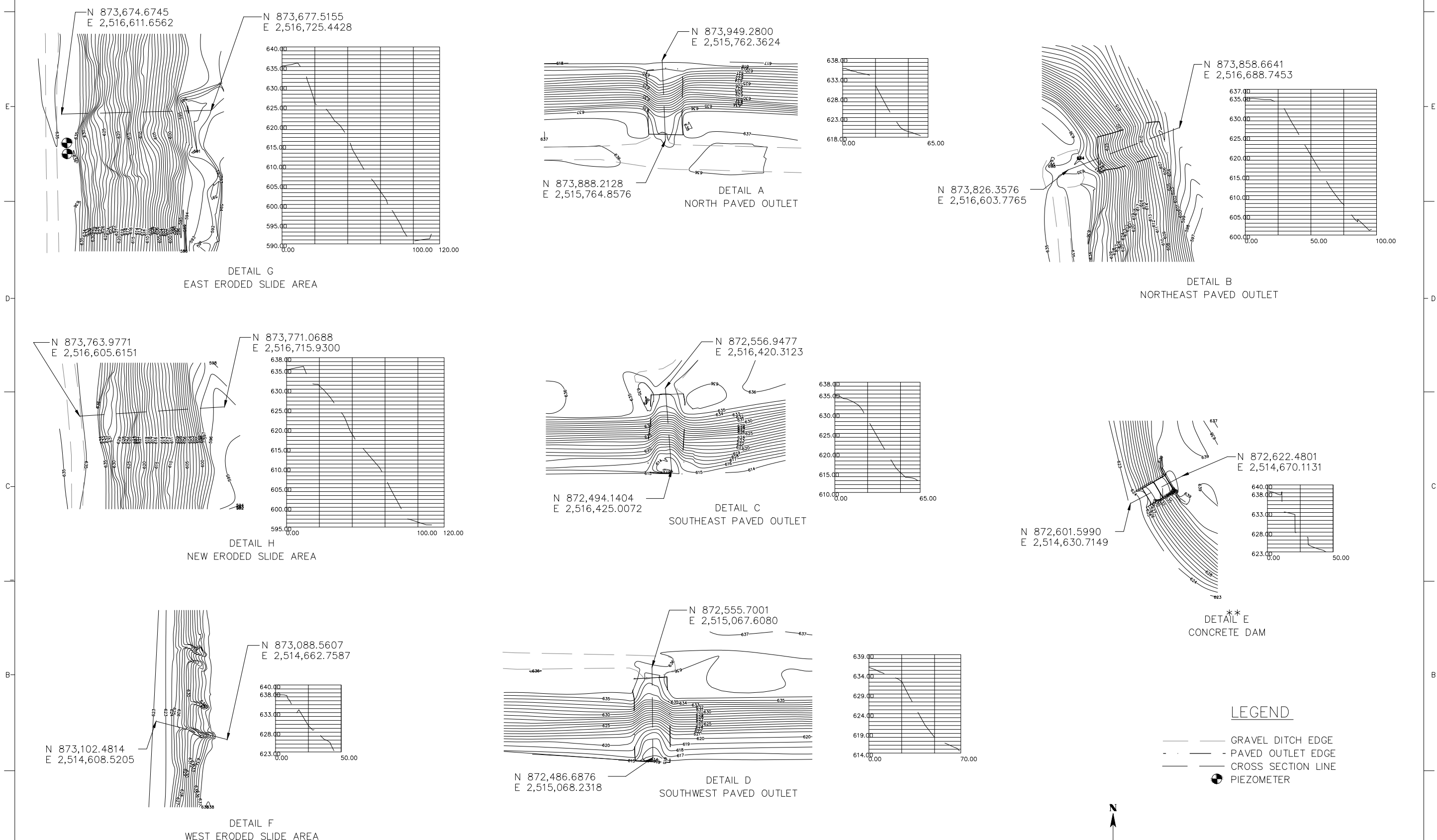

- LEGEND**
- GRAVEL DITCH EDGE
 - - - PAVED OUTLET EDGE
 - CROSS SECTION LINE
 - ⊙ PIEZOMETER

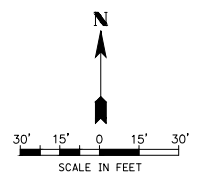

NOTICE OF LIMITED RESPONSIBILITY
THE RESPONSIBILITY OF THE UNDERSIGNED ENGINEER IS LIMITED TO THE DESIGN AND CONSTRUCTION OF THE PROJECT AS SHOWN ON THIS DRAWING. THE ENGINEER DOES NOT GUARANTEE THE ACCURACY OF THE DATA OR THE DESIGN. THE ENGINEER DOES NOT GUARANTEE THE ACCURACY OF THE DATA OR THE DESIGN. THE ENGINEER DOES NOT GUARANTEE THE ACCURACY OF THE DATA OR THE DESIGN.

AS BUILT

McDonough-Whitlow, P.C.
Consulting Engineers & Land Surveyors
138 East Wood Street
Hillsboro, IL 62049
Phone: 217.532.9233
Fax: 217.532.6300
PROFESSIONAL DESIGN NO. 184-002754

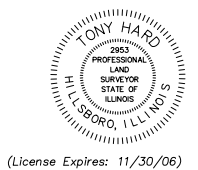

THIS IS TO CERTIFY TO AMEREN ENERGY THAT A TOPOGRAPHIC SURVEY SHOWN HEREON HAS BEEN PERFORMED BY ME OR UNDER MY SUPERVISION AND THIS PLAT IS A REPRESENTATION OF MY PROFESSIONAL OPINION OF SAID SURVEY.
ILLINOIS PROFESSIONAL LAND SURVEYOR NO. 035-2953 DATE
FIELD WORK FOR THIS SURVEY WAS COMPLETED ON MAY 28, 2009

NOTES		REFERENCE DRAWINGS		DRAWING RECORD				DESCRIPTION
REV.	DATE	PROJECT NO.	AMEREN SUPV ENGR	DRAFTING	ENGR APPROVAL	AMEREN OTHER		

SCALE	1" = 30'
PROJECT	COFFEEN POWER STATION ASH POND #2 DRAINAGE MODIFICATIONS
SITE	AMEREN CLOSED ASH POND
LOC. NO.	
CLASS	
DRAWING NO.	W1008
REV.	
SHEET NO.	2 OF 2





Appendix C: Coffeen Power Station Boring and Piezometer Locations

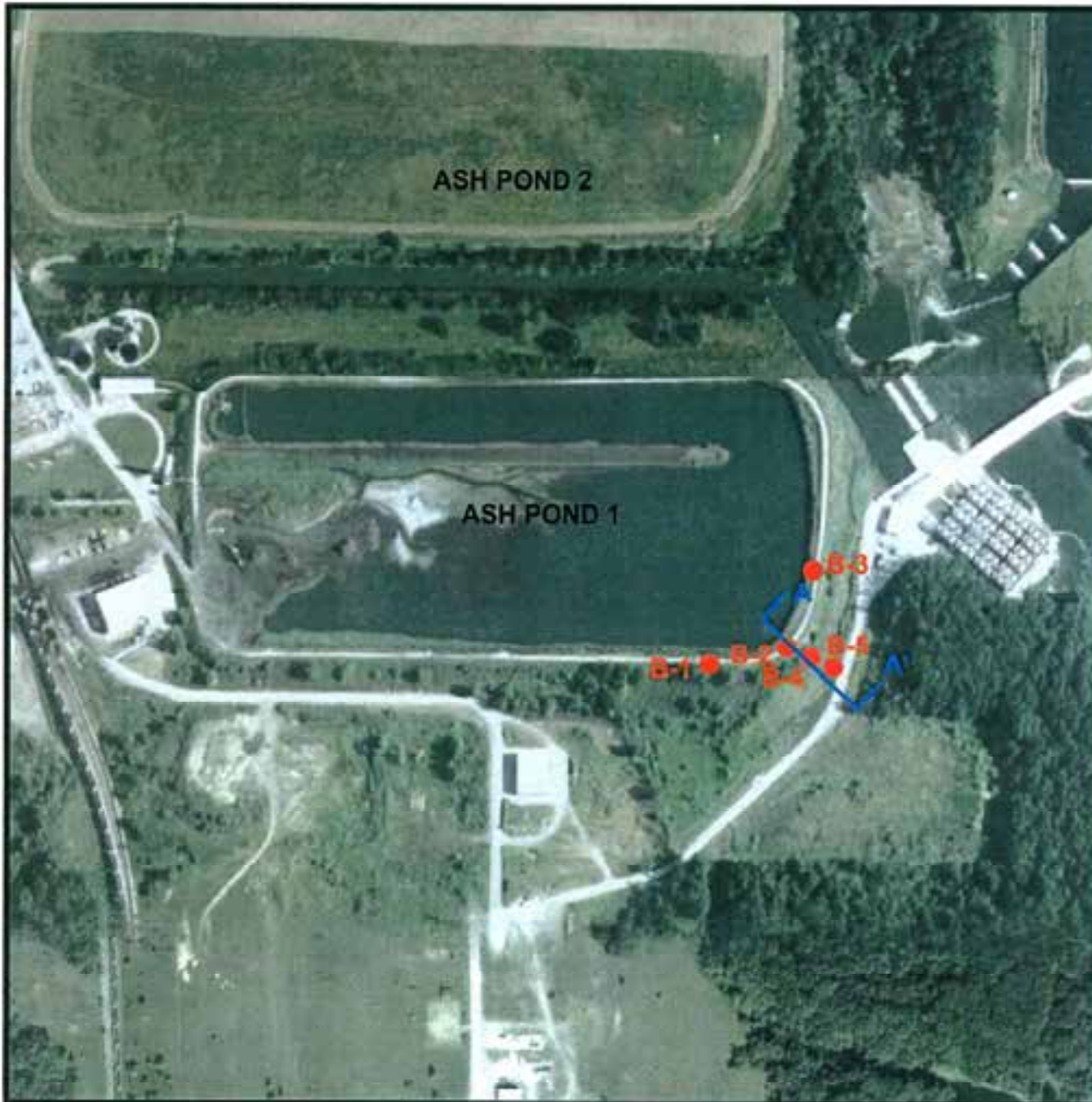

NOTES

1. Plan adapted from an aerial photograph courtesy of Google Earth.

LEGEND

- Boring Location
- Slope Stability Cross Section

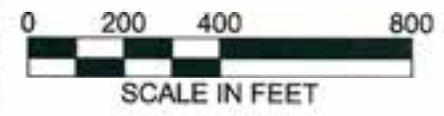

Drawn By: SLC	CK'd By: <i>SLC</i>	App'vd By: <i>SLC</i>
Date: 11-04-10	Date: <i>12/21/10</i>	Date: <i>1/4/11</i>



Coffeen Power Station
Coffeen, Illinois

**AERIAL PHOTOGRAPH OF SITE
AND BORING LOCATIONS**

Project Number J017150.01	PLATE 2
------------------------------	----------------

File: P:\PROJECTS\GEOTECH\60428794_DYNEGY\CCR\04\TASKS\00 PROGRAM TASKS\1.0 TASK 1 INITIAL UNIT ASSESSMENT\CCR FACT SHEETS\SITE MAPS\FIGURE 2A PIEZOMETER LOCATION PLAN (COFFEEN).DWG Last edited: NOV. 04. 15 @ 3:03 p.m. By: david_deguire



EXPLORATION METHOD
(B=BORING, C=CPT,
P=PIEZOMETER)

XXX-X###
ID NUMBER

STATION ABBREVIATION

SOURCE:
MAP PROVIDED BY GOOGLE EARTH PRO 2015

LEGEND

■ PIEZOMETER LOCATION

--- CCR UNIT BERM ALIGNMENT

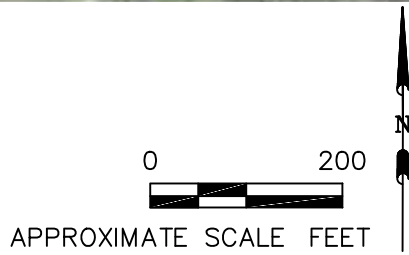

Illinois Power Generating Company	PROJECT NO. 60440742	
AECOM		
DRN. BY:djd October 2015 DSGN. BY:eg CHKD. BY:eg	Coffeen Ash Pond No.1 Piezometer Locations	FIG. NO. 2A

File: P:\PROJECTS\GEOTECH\60428794_DYNEGYCCR\04\TASKS\00 PROGRAM TASKS\1.0 TASK 1 INITIAL UNIT ASSESSMENT\CCR FACT SHEETS\SITE MAPS\FIGURE 2A PIEZOMETER LOCATION PLAN (COFFEEN).DWG Last edited: NOV. 04. 15 @ 3:03 p.m. by: david_dequire



COFFEEN ASH POND NO. 2

LEGEND

- AECOM PIEZOMETER LOCATION
- HISTORICAL PIEZOMETER LOCATION



CCR UNIT BERM ALIGNMENT



APPROXIMATE SCALE FEET



Illinois Power Generating Company	PROJECT NO. 60440742
-----------------------------------	-------------------------



DRN. BY:djd October 2015 DSGN. BY:eg CHKD. BY:eg	Coffeen Ash Pond No.2 Piezometer Locations	FIG. NO. 2B
--	---	----------------

SOURCE:
MAP PROVIDED BY GOOGLE EARTH PRO 2015



Appendix D: Project Specifications, Gypsum Stack and Recycle Pond Construction (Hanson 2008)

PROJECT SPECIFICATIONS
GYPSUM STACK AND RECYCLE POND CONSTRUCTION
GYPSUM MANAGEMENT FACILITY
COFFEEN POWER STATION
MONTGOMERY COUNTY, ILLINOIS

Prepared For:

AMEREN ENERGY GENERATING COMPANY

Prepared By:

HANSON PROFESSIONAL SERVICES INC.
1525 South Sixth Street
Springfield, Illinois 62703

January 2008

GYPSUM STACK AND RECYCLE POND CONSTRUCTION
GYPSUM MANAGEMENT FACILITY
COFFEEN POWER STATION
MONTGOMERY COUNTY, ILLINOIS

TABLE OF CONTENTS

	<u>Sheet No.</u>
<u>Division 1 – General Requirements</u>	
01356 - Storm Water Pollution Prevention Measures	01356-1 to 01356-3
<u>Division 2 – Site Work</u>	
02100 - Site Preparation	02100-2
02200 - Earthwork	02200-1 to 02200-12
02275 - Riprap	02275-1 to 02275-2
02315 - Granular Drainage Materials	02315-1 to 02315-8
02373 - Geotextiles	02373-1 to 02373-8
02376 - Geosynthetic Clay Liner	02376-1 to 02376-9
Attachment 1 – Bentomat® Certified Properties	End of Section
02640 - HDPE Piping	02640-1 to 02640-4
02800 - HDPE Geomembrane	02800-1 to 02800-12
02936 – Topsoil Seeding and Mulching	02936-1 to 02936-3
03100 – Concrete Formwork	03100-1 to 03100-5
03200 – Concrete Reinforcement	03200-1 to 03200-3
03300 – Cast-In-Place Concrete	03300-1 to 03300-6
03400 – Concrete Embedment Liner	03400-1 to 03400-4

DIVISION 1—GENERAL REQUIREMENTS
Section 01356 – Storm Water Pollution Prevention
Measures

PART 1. GENERAL

1.01 DESCRIPTION

- A. This section pertains to the construction and maintenance of temporary erosion control systems to control erosion and sediment damage to adjacent properties and water resources, and the removal of erosion control devices when they are no longer required.

1.02 RELATED SECTIONS

The following sections contain items which are related to the work in this section:

02936 - Topsoil, Seeding, and Mulching.

1.03 REFERENCES

The following reference, or cited portions thereof, governs the work:

Illinois Department of Transportation (IDOT): Standard Specifications for Road and Bridge Construction, adopted January 1, 2007.

1.04 SUBMITTALS

- A. Submittals shall follow the provisions of Section 01010.
- B. Preconstruction Submittals: A storm water best management practices (BMP) plan shall be submitted that includes the following items:
1. Site drawing showing anticipated locations of structural erosion controls, areas of disturbed soils, and drainage patterns;
 2. Inspection and record-keeping procedures; and
 3. Maintenance procedures for erosion controls.

PART 2. PRODUCTS

2.01 EROSION CONTROL SYSTEMS

Materials for erosion control systems shall be in accordance with Article 280.02 of the IDOT Standard Specifications.

PART 3. EXECUTION

3.01 EXAMINATION

The site shall be examined to determine the extent of work required.

3.02 PRECONSTRUCTION JOBSITE INSPECTION

- A. The person who shall be at the jobsite during construction and who shall be responsible for insuring that erosion control work is completed in a timely manner shall be identified at the preconstruction meeting.
- B. A jobsite inspection shall be conducted with the Owner's Representative to review and designate the locations and types of erosion protection to be placed. The inspection shall be scheduled at the preconstruction conference and carried out on the job site before beginning any work that will disturb existing drainage or potentially create erodible conditions.

3.03 CONSTRUCTION

- A. Temporary erosion control systems shall be constructed in accordance with IDOT Standard 280001 and Article 280.04 of the Standard Specifications and as directed by the Owner's Representative. Erosion control devices shall be in place and approved by the Owner's Representative prior to beginning other work.
- B. Incorporate permanent erosion control features into the project at the earliest practicable time to minimize the need for temporary erosion controls.

3.04 MAINTENANCE

- A. Temporary erosion control systems shall be maintained in accordance with Article 280.05 of the Standard Specifications, except that measurement and payment provisions shall not apply.
- B. Temporary erosion control systems for unprotected disturbed areas shall be cleaned of trapped sediment and repaired immediately prior to project close out.
- C. Temporary seeding shall be applied to all disturbed areas except the gypsum stack excavation and the future fill and topsoil stockpiles.

3.05 REMOVAL AND DISPOSAL

When the Owner's Representative deems that temporary erosion control systems are no longer needed, they shall be removed and properly disposed, and silt deposits shall be removed or regarded as directed by the Owner's Representative, and the area seeded. Non-biodegradable temporary erosion control materials shall be disposed of off site. Biodegradable erosion control devices may be disposed of in spoil areas designated by the Owner's Representative. All laws and regulations in disposing of the materials shall be obeyed.

END OF SECTION 01356

I:\05jobs\05s3004A\Gypsum Stacking\IDNR Dam Safety Permit Application\Specs\501356_Storm Water Pollution Prevention Measures.doc

PART 1. GENERAL

1.01 DESCRIPTION

This section pertains to stripping of topsoil and vegetation from areas of the site that are to be excavated.

1.02 RELATED SECTIONS

No related sections.

PART 2. PRODUCTS

No products used.

PART 3. EXECUTION

3.01 EXAMINATION

The Contractor shall examine the site to determine the extent of work required.

3.02 SITE PREPARATION - STRIPPING

- A. All vegetation and topsoil encountered within the Gypsum Stack grading limits shall be stripped. Topsoil shall be kept clean and free of all foreign material, and stored in separate stockpiles from vegetation and common excavations. Stockpiles shall be located as indicated on the drawings or as directed by the Owner's Representative.
- B. Payment for stripping shall be based upon removal of 24 inches of topsoil in areas that require stripping.

3.03 DISPOSAL

All materials resulting from site preparation operations shall be stockpiled in the designated spoil area. Contractor shall obey all laws and regulations when disposing of the materials.

END OF SECTION 02100

I:\03jobs\03s5010\Gypsum Stack\Specs\Gypsum Mangement Facility\Pre-Final Specs\S02100_Site Preparation.doc

PART 1. GENERAL

1.01 DESCRIPTION

This section pertains to excavation, fill, and backfill required for foundation preparation, construction of low-permeability soil layer, anchor trench construction, miscellaneous site grading and berm construction.

1.02 RELATED SECTIONS

- A. The following sections contain items which are related to the work in this section:
1. 01356 – Storm Water Pollution Prevention Measures
 2. 02100 - Site Preparation
 3. 02373 – Geotextiles
 4. 02936 - Topsoil, Seeding, and Mulching

1.03 REFERENCES

The following references, or cited portions thereof, govern the work:

1. Illinois Department of Transportation (IDOT): Standard Specifications for Road and Bridge Construction, adopted January 1, 2007
2. Department of Sustainable Natural Resources, Soil Survey Standard Test Method, Unified Soil Classification System: Field Method (USCS).

1.04 MEASUREMENT AND PAYMENT

- A. The Contractor shall be responsible for estimating the extent of excavation and fill required to complete the work, including, but not limited to, excavation to required elevations; loading, transporting, placing, and compacting low permeability soil; excavation and backfill of anchor trench; and miscellaneous site grading and berm construction. The Contractor shall include the dollar amount associated with all earthwork in his Lump Sum Bid amount.
- B. Removal and replacement of unsuitable foundation material and subgrade stabilization measures directed by the Owner's Representative will be paid for on a time and material basis.

1.06 COORDINATION

Existing utilities or other plant facilities shall not be interrupted, except when permitted in writing by the Owner's Representative and then only after acceptable

temporary services have been provided. A minimum 48-hour notice shall be provided prior to proceeding with an approved temporary interruption.

1.08 SUBMITTALS

A. Materials Handling Plan.

A materials handling plan shall be submitted for construction and protection of the low permeability soil liner. The plan shall describe the following:

1. Processing and placement of the low permeability soil type, model number, weight, and critical dimensions of equipment to be used for soil processing, compaction, scarification, and smooth rolling;
2. Method of protecting low permeability soil from changes in moisture content and freezing after placement.

B. Construction Access Ramp Layout.

Layout drawings shall be submitted showing alignment, profile, and typical section of the construction access ramps from the haul road into the bottom of the Gypsum Management Facility excavation. The minimum width of the ramp shall be 50 ft., and the longitudinal grade shall not exceed 8 percent.

PART 2. PRODUCTS

2.01 MATERIALS

A. Earth Fill Material

Earth Fill Material shall consist of a mixture of clay, silt, sand, and gravel-sized particles obtained from previously constructed subsoil stockpiles. These materials can be used separately or mixed as required for best results. When placed, Embankment Material shall have a USCS classification of SM, ML, or CL and shall be uniform. This material shall be free of ice, snow, organic matter, rubbish, and debris. Coarse-grained particles shall be well dispersed to prevent the development of segregated pockets or zones with insufficient fine material to fill the interstices.

B. Soil Liners

The Soil Liner for the Gypsum Management Facility is considered a Clay Liner, and shall be soil classification CL, CL-ML, or CH. The material shall be free of roots, debris, organic or frozen material, and shall have a maximum clod size no greater than the length of the compactor foot for the compaction equipment proposed by the Contractor. When compacted, the material shall have a hydraulic conductivity of less than 1×10^{-4} cm/sec.

C. Soil Stabilizers and Moisture Conditioning Agents

Additives to accelerate drying or to improve stability and workability of soil shall not be permitted unless approved in writing by the Owner's Representative.

2.02 EQUIPMENT

A. Compaction Equipment

1. Tamping foot rollers

Compaction equipment shall consist of tamping foot rollers which have a minimum weight of 40,000 pounds. At least one tamping foot shall be provided for each 110 square in. of drum surface. The length of each tamping foot, measured from the outside surface of the drum, shall be at least 1 in. longer than the loose lift thickness.

2. Steel-Wheeled Rollers

Equipment used to produce a smooth compacted surface shall be a smooth, non-vibratory steel wheeled roller weighing not less than 1,000 lb. per lineal ft.

B. Scarification Equipment

Discs, rotor tillers, or other equipment used to scarify the surface shall be capable of uniformly disturbing the upper 6 in. of surface to provide good bonding between lifts.

C. Mixing and Spreading Equipment

Discs, harrows, and motor graders or other similar equipment shall be available at the site for use in spreading, mixing, and drying Compacted Subsoil Stockpile Material.

PART 3. EXECUTION

3.01 PREPARATION

A. Control of Work

Benchmarks, monuments, and other reference points shall be maintained throughout the work area.

B. Utility Location

Before starting excavation, the location and extent of underground utilities in the work area shall be established.

3.02 EXCAVATION

A. General

Excavation consists of removal and redistribution of material encountered when establishing required grade and subgrade elevations. The Contractor shall be responsible for dewatering, protection, shoring, and disposal of excavated materials as necessary to complete the excavation.

B. Procedures

Excavation may be accomplished by any method and by use of any equipment that is suitable to the work, except that blasting will not be permitted. Based on previous construction experience at the site, it is recommended that excavation to the foundation grade be completed as far in advance of low permeability soil placement as possible to allow the foundation surface to dry and form a "crust" capable of sustaining compactive effort.

C. Overexcavation

All excavation shall be performed to the lines and grades indicated on the plans. Any overexcavation or excess excavation not requested by the Owner's Representative shall be at the expense of the Contractor.

D. Disposal of Excavated Materials

Contractor shall utilize excavated material as stockpile materials for future use as specified in paragraph E.

E. Stockpile Requirements

1. Excavated clay and silty clay materials are to be stockpiled in the short-term subsoil stockpile area.
2. Excess excavated materials are to be stockpile in the areas designated on the drawings.
3. Materials not suitable for use as fill or backfill shall be disposed of onsite in the locations specified by the Owner's Representative.
4. Spread fill material for use by others, topsoil, and low permeability soil are to be stockpiled in layers not to exceed 1 ft loose thickness.
5. Tops of stockpiles are to be graded to ensure positive drainage. Side slopes for stockpiles shall be no steeper than 3H:1V.
6. Perimeter ditches are to be excavated to intercept runoff flowing toward stockpile areas and to route it to outlet locations approved by the Owner's Representative.

3.03 SUBGRADE PREPARATION

- A. Areas to receive fill shall be proof rolled under the observation of the Owner's Representative. Soft, loose, weak, or wet materials shall be removed and replaced with compacted fill or stabilized with geotechnical fabric or geogrid as directed by the Owner's Representative. Joints, fractures, and moisture seeps shall be repaired, and local sand deposits, if present at foundation grade, shall be removed and backfilled with compacted fill material as directed by the Owner's Representative.
- B. The Owner's Representative may recommend additional drying time for soft, wet subgrade that has not been exposed long enough to permit "crust" formation. If approved by the Owner's Representative, the Contractor may install, at his own expense, geotechnical fabric or geogrid to stabilize the wet subgrade and expedite construction.
- C. No fill shall be placed until the subgrade has been examined and approved.

3.04 GENERAL FILL

- A. Placement
 - 1. Unless otherwise indicated on the plans, all fill shall be composed of Earth Fill Material.
 - 2. Fill materials used in embankment construction shall normally be placed in lanes parallel to the embankment axis and shall be placed in conformance with the lines, grades, and slopes as indicated on the plans. Placement of fill materials in lanes which are not parallel to the embankment will be allowed only where working room is too restricted for normal placement as determined by the Owner's Representative.
 - 3. Fill shall be spread in approximately flat layers in such a manner as to obtain lifts of relatively uniform thickness without spaces between successively deposited loads. Segregation shall be prevented during placing and spreading. Hauling equipment shall be routed across the fill in such a way as to promote uniform compaction and to prevent the formation of ruts.
 - 4. The maximum compacted thickness of each lift shall not exceed 8 in. where heavy compaction equipment will be used. The maximum compacted thickness shall not exceed 3 in. where power tampers or similar smaller equipment will be used. It may be necessary to reduce the thickness of lifts in order to obtain the required minimum density.
 - 5. Where compacted earth fill is to be placed against existing slopes, each lift shall be keyed into existing slope by removing existing slope material in steps as each new lift is placed.
 - 6. The surface of the fill shall be kept reasonably smooth. The fill surface shall be sloped transverse to the axis of the embankments to allow drainage. If the compacted surface is, in the opinion of the Owner's Representative, too smooth or too dry to bond properly with the

succeeding lift, it shall be roughened by scarifying, light discing, or other acceptable means, and it shall be sprinkled before the succeeding lift is placed thereon. If the surface becomes rutted or uneven subsequent to compaction, it shall be flattened and leveled before placing the next lift. This extra work shall be at the Contractor's expense.

7. Fill operations shall be suspended during periods of extended wet weather. Upon resuming operations, all fill materials that are excessively wet or soft shall be reprocessed in place or removed and stockpiled for reprocessing. The removal of soft material shall be carried to such depth as is necessary to expose firm materials. Fill shall not be placed on frozen surfaces.
8. When filling operations at any section will be suspended for any period in excess of 12 hours or in wet weather, the surface of the fill shall be rolled smooth to seal it against excessive absorption of moisture and to facilitate runoff. Prior to resuming fill placement and compaction, the fill surface shall be scarified and/or disc'd and moisture conditioned as required.
9. The Contractor will receive no additional compensation for any removal, reprocessing, stockpiling, recompaction, wasting, or similar operation related to suspensions or conditions due to weather or other causes unless caused by the Owner.
10. Earth fill access ramps shall not be constructed within the limits of the compacted embankments without prior approval. When such ramps are approved, they shall be constructed of low permeability soil (in-board of the perimeter berm) or compacted fill (out-board of the perimeter berm).

B. Compaction -

1. Fill materials shall be compacted to a dry density equal to or greater than the following:
 - a. The Gypsum Management Facility: 95 percent of the maximum dry density obtained from the Standard Proctor Test, ASTM D698.

In order to insure uniform coverage and to facilitate construction inspection and control, the compaction of each layer shall proceed in a systematic, orderly, and continuous manner. Rolling shall be parallel to the embankment axis, except where there is insufficient working room for such operations.

2. The moisture content of all earth fill materials shall be as uniform as practicable throughout each lift. Fill shall be compacted at a moisture content that is no more than 2 percent below and no more than 2 percent above optimum moisture content.
3. Moisture conditioning of fill materials shall be performed by discing, harrowing, plowing, blading, or other suitable means prior to excavation. Moisture conditioning where the fill is placed shall be limited to minor adjustments prior to compaction. Addition of moisture shall be by using a

- pressure spray bar mounted in front of or to one side of a water tanker so that water will not collect in the tracks of the truck.
4. Compaction of fill materials shall not commence if the moisture content is not within the specified limits. Any materials that are placed but not compacted prior to drying out or becoming too wet shall be removed and replaced or reprocessed at the Contractor's expense.
 5. No admixtures as drying agents or to improve the workability of the soil will be allowed.

3.05 SOIL LINERS

A. Sources

The Soil Liners for the Gypsum Management Facility shall be constructed from Soil Liner Material as described in paragraph 2.01(B) above.

B. Test Liner

A compacted low permeability soil test liner of the actual full scale liner shall be constructed in accordance with the following requirements:

1. Test liner will be constructed from the same soil material sources, to the same design specifications, and with similar equipment and procedures as are proposed for the full scale liner.
2. Test liner will be at least four times the width of the widest piece of equipment to be used.
3. Test liner will be no less than 100 ft long to allow equipment to reach normal operating speed before reaching a central 40-ft test area.
4. Test liner will be constructed with maximum 8-in. compacted lifts for a total liner thickness of 3 ft.
5. Test liner will be tested by the Owner's Testing Consultant as described below for each of the following physical properties:
 - a. Multiple two-stage Boutwell permeameter tests will be used on the test liner to determine the hydraulic conductivity. The two-stage field hydraulic conductivity test is a falling head infiltration test conducted in a cased borehole, typically 4 in. in diameter. The test is cited in the U.S. EPA Technical Guidance Document: Quality Assurance and Quality Control for Waste Containment Facilities, September 1993 (EPA/600/R-93/182).
 - b. Undisturbed samples (Shelby tubes) will be tested in the laboratory for hydraulic conductivity to determine if there is a statistical correlation to the field testing results.
 - c. Other engineering parameters including, but not limited to, particle size analysis, liquid limits, plasticity, water content, and in-place density that are needed to evaluate the full scale liner will be determined.

6. Additional test fills will be constructed for each new soil type or for each change in equipment or procedures.

C. Full Scale Liner Construction:

1. Full scale liner construction shall not be commenced until the results of the in-place compaction testing and Boutwell permeameter tests on the test liner confirm that the construction procedures and specified compaction requirements produce a in-situ hydraulic conductivities as specified in Section 2.01(B) above.
2. The liner shall be constructed according to the placement and compaction requirements for general fill, except the material shall be compacted to a density of no less than 95 percent of maximum dry density at a moisture content between 100 percent and 105 percent of optimum. The same compaction procedures, such as number of passes, speed, and compaction equipment used on construction of the test liner shall be used. Grade stakes shall not be driven into the clay liner.
3. The completed liner shall be smooth rolled to limit moisture loss and promote run-off of surface water. Moisture content shall be maintained within the specified range and erosion or other damage that occurs in the soil liner shall be repaired as directed by the Owner's Representative until the geosynthetic liner is placed.
4. Repair of any rutting or other damage caused by the installation of the geosynthetic liner will be paid for on a time and material basis.
5. Voids created in the clay barrier layer during construction (including, but not limited to, penetrations for test samples, and other penetrations necessary for construction) shall be repaired by removing material that does not meet the requirements for low permeability soil, placing low permeability soil backfill, granular or pelletized bentonite, or a mixture of bentonite and low permeability soil in lifts no thicker than 2 in. and tamping each lift with a steel rod. Each lift shall be tamped a minimum of 25 times altering the location of the rod within the void for each blow. Other ruts and depressions in the surface of the lifts shall be scarified, filled, and then compacted to grade.

3.06 CUSHION DIRT

Cushion Dirt to be placed beneath the upper High Density Polyethylene (HDPE) Geomembrane is to be placed to the specifications for General Fill in Section 3.04 above, except fill materials for Cushion Dirt shall be compacted to a dry density equal to or greater than 90 percent of the maximum dry density obtained from the Standard Proctor Test, ASTM D698.

3.07 ANCHOR TRENCH CONSTRUCTION

A. Gypsum Management Facility

1. A ledge at the bottom of the anchor trench elevation shall be excavated. Low permeability soil shall be placed and compacted on the ledge as shown on the anchor trench details in the plans.
2. The anchor trench shall be excavated to the depth and width shown on the anchor trench details. The front edge of the trench shall be rounded to eliminate any sharp corners that could cause excessive stress to the geosynthetic liners. Loose soil shall be removed or compacted into the floor of the trench.
3. Subsequent to Geosynthetic Clay Liner (GCL), Bottom HDPE Geomembrane and Geotextile Cushion installation, it shall be verified that the liners cover the entire trench floor, but do not extend up the back of the trench wall. After the liner installation in the trench has been inspected and approved by the Owner's Representative, the trench shall be backfilled with 1 ft. of low permeability soil. The backfill shall be deposited and compacted according to the requirements for general fill in such a manner as to prevent damage to the GCL and liner materials.
4. Subsequent to installation of separation geotextile on top of drainage layer, it shall be verified that the fabric extends across the top of the initial 1 ft layer of trench backfill, but does not extend up the back of the trench wall. After the fabric installation in the trench has been inspected and approved by the Owner's Representative, the trench shall be backfilled with 1 ft of low permeability soil. The backfill shall be deposited and compacted according to the requirements for general fill in such a manner as to prevent damage to the geotextile fabric.
5. Subsequent to installation of the upper HDPE Geomembrane, verify that the liner extends across the top of the initial 1 ft layer of trench backfill, but does not extend up the back of the trench wall. After the liner installation in the trench has been inspected and approved by the Owner's Representative, backfill the remainder of the trench to the top of the low permeability soil layer. Deposit and compact the backfill according to the requirements for general fill in such a manner as to prevent damage to the HDPE Geomembrane.

3.08 TESTING

- A. Construction Quality Assurance (CQA) compaction and permeability tests will be made by the Owner's Testing Consultant during the progress of the work as indicated in Appendix 2. The Contractor shall cooperate with the Testing Consultant and allow such tests to be performed.

- B. If tests indicate that an area of fill or low permeability soil liner does not meet the specified requirements, additional tests shall be performed to determine the extent of non-compliance. The Contractor shall moisture condition and recompact that area until a passing test result is obtained.

3.08 FINISH GRADING

All excavated and filled areas shall be fine graded and leveled to provide a smooth finish free of debris, foreign matter, objectionable stones, clods, lumps, pockets, or high spots, properly drained and true to indicated elevations. Finish grading shall be only near completion of work or when requested. Any portions of the berm damaged by construction shall be restored. The berm ditch shall be finished to design grade, and the ditch side slopes shaped and trimmed to provide a uniform ditch cross section.

3.09 CONSTRUCTION TOLERANCES

- A. The foundation grade and finished earthwork grades shall be no more than 0.4 ft below and not above plan grade.
- B. The minimum thickness of low permeability soil layer shall be 3 ft.

END OF SECTION 02200

I:\05jobs\05s3004A\Gypsum Stacking\IDNR Dam Safety Permit Application\Specs\S02200_Earthwork.doc

PART 1. GENERAL

1.01 DESCRIPTION

This section pertains to the placement of riprap for erosion control.

1.02 RELATED SECTIONS

The following section contains items which are related to the work in this section:

02200 - Earthwork

1.03 REFERENCES

Specified references or cited portions thereof, current at date of bidding documents unless otherwise specified, govern the work.

- A. Illinois Department of Transportation (IDOT): Standard Specifications for Road and Bridge Construction, adopted January 1, 2007.

1.04 SUBMITTALS

Product Data: Provide quarry name and material type prior to delivery.

PART 2. PRODUCTS

2.01 MATERIALS

- A. Stone Riprap and Bedding materials according to Article 1005.01 of the Illinois Standard Specifications for Road and Bridge Construction.
- B. Filter Fabric material for Stone Riprap according to Article 1080.03, with an AOS (Apparent Opening Size) as indicated on the plans.
- C. Supplier shall be listed on the current IDOT Approved Aggregate Source List.
- D. Gradation as indicated in the drawings. Quality shall be Class A.

PART 3. EXECUTION

3.01 CONSTRUCTION REQUIREMENTS

- A. Stone Riprap and Bedding shall be installed in accordance with Section 281 of the Illinois Standard Specifications for Road and Bridge Construction for the placement of Stone Riprap. Measurement and payment provisions of Section 281 shall not apply.
- B. Filter Fabric for Stone Riprap shall be installed in accordance with Section 282 of the Illinois Standard Specifications for Road and Bridge Construction.
- C. The Owner's Representative shall be allowed to visually inspect Riprap for compliance with specifications prior to placement.

END OF SECTION 02275

DIVISION 2 – SITEWORK
Section 02315 – Granular Materials

PART 1. GENERAL

1.01 DESCRIPTION

A. Gypsum Management Facility

This section pertains to the following:

1. Furnishing and placing granular drainage materials for the drainage layer and leachate collection system.
2. Furnishing and placing coarse aggregate for encasement of the ring drain collection piping.
3. Furnishing and installing materials for roadbed construction related to the Gypsum Management Facility access roads and the McKinley Road relocation.
4. Recycle Pond Drain.

1.02 RELATED SECTIONS

The following sections contain items which are related to the work in this section:

1. 02300 - Earthwork
2. 02373 – Geotextiles
3. 02640 - HDPE Piping

1.03 REFERENCES

The following references, or cited portions thereof, govern the work:

1. Illinois Department of Transportation (IDOT): Standard Specifications for Road and Bridge Construction, adopted January 1, 2007.
2. American Society for Testing and Materials (ASTM):
 - a. ASTM D 75 (2003) Practice for Sampling Aggregates.
 - b. ASTM D 422 (1963; R 2002) Test Method for Particle-Size Analysis of Soils.
 - c. ASTM D 2434 (1968, R 2000) Test Method for Permeability of Granular Soils (Constant Head).
 - d. ASTM D 3042 (2003) Test Method for Insoluble Residue in Carbonate Aggregates.
 - e. ASTM C 1260 (2005) Standard Test Method for Potential Alkali Reactivity of Aggregates (Mortar-Bar Method).

3. American Geological Institute (AGI). Geoscience Handbook AGI Data Sheets, 4th Edition.

1.04 MEASUREMENT AND PAYMENT

The Contractor shall be responsible for estimating the extent of granular materials required to complete the work including, but not limited to, construction of drainage layer, encasement of leachate collection piping, and road-bed construction. The Contractor shall include the dollar amount associated with furnishing and placing all granular materials in his Lump Sum Bid amount.

1.05 COORDINATION

- A. The geosynthetic liner shall be covered with granular materials as soon as practicable after a section of liner has been approved by the Owner's Representative.

1.06 SUBMITTALS

- A. Product Data:
 1. Aggregate source list: Submit a list of proposed aggregate sources.
 2. Shipping Tickets: Submit shipping tickets for the granular materials delivered to the site. Shipping tickets shall be according to paragraph 1004.01f of the IDOT Standard Specifications.
- B. Test Reports.
 1. Submit results of grain size analysis (ASTM D422) and hydraulic conductivity testing (ASTM D2434) for gradations established by the Contractor that provide the specified hydraulic conductivity. Test results are required for each proposed source and gradation. Submit test results for each source demonstrating compliance with reactivity, soundness, and abrasion requirements specified herein.
- C. Samples:
 1. Submit one sample per source for each gradation proposed for use on the project. Samples shall be at least one pound and shall be obtained and shipped according to ASTM D75. Submit samples at least 15 days prior to starting construction of the drainage layer and coarse aggregate encasement for leachate piping.

1.07 STORAGE AND HANDLING

- A. Storage and handling of granular materials shall be according to paragraph 1004.01e of the IDOT Standard Specifications.

1.01

PART 2. PRODUCTS

2.01 MATERIALS

A. General

1. Unless otherwise approved by the Owner's Representative, granular materials shall be obtained from sources listed on the current IDOT Approved Aggregate Source List (www.dot.il.gov/materials/approvedaggregatesources.pdf).
2. Coarse Granular materials shall meet the Description of Gravel, as described in Section 1004.01(a)(1) of the IDOT Standard Specifications, and shall be spherical to sub-discoidal, sub-rounded to well rounded particles as defined by AGI Data Sheet, 4th Edition, Sheet 8.4 – Comparison Charts for Estimating Roundness and Sphericity.
3. Granular materials shall experience no more than 15 percent carbonate loss per ASTM D3042.
4. Granular materials shall be free of deleterious material, and shall meet the Na₂SO₄ soundness and Los Angeles Abrasion Specifications for Class B quality aggregate per paragraph 1004.01 of the IDOT Standard Specifications.
5. All material shall pass the 2 in. sieve, and no greater than 5 percent shall be retained on the No. 200 sieve.
6. Granular materials shall be innocuous to alkali-silica reactivity, and shall exhibit internal expansions of less than 0.10 percent at 16 days after casting as determined by ASTM C 1260.

B. Gypsum Management Facility Granular Materials

1. Granular Materials for Drainage Layer

Gradation for granular material for drainage layer shall be as required to provide a minimum hydraulic conductivity (ASTM D2434) of 1×10^{-3} cm/sec.

2. Coarse Aggregate around Ring Drain Collection Piping

Coarse Aggregate used to encase the ring drain collection piping shall be IDOT Gradation CA 7 material as outlined in Article 1004.01 of the IDOT Standard Specifications for Road and Bridge Construction.

3. Filter Sand

Filter Sand used for protective cover over the ring drain collection system shall be IDOT Gradation FA 1, Class B or better according to Article 1003 of the IDOT Standard Specifications for Road and Bridge Construction.

4. Aggregate Base Course, Type B

Aggregate Base Course, Type B used for base material for all new access roads and shall be IDOT Gradation CA 2, in accordance with Section 1004.04 of the IDOT Standard Specifications for Road and Bridge Construction. The material shall originate from an IDOT approved source. The Na_2SO_4 soundness and Los Angeles Abrasion Specifications for Class B quality aggregate per paragraph 1004.01 of the IDOT Standard Specifications shall not apply.

5. Aggregate Surface Course, Type B

Aggregate Surface Course, Type B used for surface material for all new access roads and the McKinley Road relocation shall be IDOT Gradation CA 6, in accordance with Section 1004.04 of the IDOT Standard Specifications for Road and Bridge Construction. The material shall originate from an IDOT approved source. The Na_2SO_4 soundness and Los Angeles Abrasion Specifications for Class B quality aggregate per paragraph 1004.01 of the IDOT Standard Specifications shall not apply.

2.02 EQUIPMENT

Equipment for spreading and compacting granular materials shall be low ground pressure equipment to prevent damage to the underlying geosynthetic liners.

PART 3. EXECUTION

3.01 PROTECTION OF GEOSYNTHETICS

- A. Protection of the geosynthetic liners is critically important. Approved geosynthetic liner shall be covered by granular material as soon as practicable. Granular material shall be placed to a minimum thickness of 1 ft before any heavy equipment or loaded trucks are allowed on the lined area.
- B. No equipment will be permitted directly on the geosynthetic liner.
- C. Any damage to the geosynthetic liner system shall be repaired, as directed by the Owner's Representative, at the expense of the Contractor.

3.02 GRANULAR DRAINAGE LAYER (GYPSUM MANAGEMENT FACILITY)

A. Placement on Cell Floor

- 1. The granular material shall be back-dumped on the geotextile cushion fabric in a sequence of operations beginning at the perimeter of the liner on the cell floor.
- 2. Placement of material on the fabric shall be accomplished by spreading dumped material off of previously placed material with a bulldozer blade or endloader, in such a manner as to prevent tearing or shoving of the cloth. Dumping of material directly on the fabric will only be permitted to establish an initial working platform. No vehicles or construction equipment shall be allowed on the fabric prior to placement of the granular blanket to a minimum thickness of 1 ft.

B. Placement on Cell Side Slopes

- 1. Placement of granular material on cell side slopes shall be accomplished using methods and equipment similar to that specified for placement of material on cell floor.
- 2. The Contractor may place gypsum underlain with separation geotextile fabric to buttress the granular material on the slope:
 - a. The Construction Quality Assurance (CQA) survey to certify thickness of drainage material shall be completed within the footprint of the gypsum stack before gypsum placement.

- b. Separation geotextile fabric shall extend beyond the toe of gypsum buttress a sufficient distance to prevent contamination of the granular drainage layer. See Sections 02373 and 02320 for construction of separation geotextile fabric and gypsum, respectively.

3.04 COARSE AGGREGATE FOR ENCASEMENT OF RING DRAIN COLLECTION PIPING (GYPSUM MANAGEMENT FACILITY)

- A. The geotextile filter fabric for encasement of leachate collection piping shall be placed on the approved cushion geotextile fabric according to Section 02373 – Geotextiles.
- B. The coarse aggregate shall be placed on the encasement fabric to the width shown on the plans to the level of the bottom of the ring drain collection piping.
- C. Course aggregate shall be placed and tamped along the pipe during pipe installation. The coarse aggregate shall be placed longitudinally along the pipe in lifts not to exceed 8 in. thick to a height of at least the center of the pipe. The aggregate shall be maintained at equal elevation on each side of the pipe, and the first lift of material shall be mechanically tamped to ensure that the space under the pipe is completely filled. The top of pipe shall not be covered until the CQA survey certifies leachate piping grade has been completed.
- C. After the CQA survey has been completed, coarse aggregate material shall continue to be placed in lifts not to exceed 8 in. thick, as specified in the previous paragraph until the minimum cover height shown in the plans is attained.
- D. The running of trucks or heavy equipment over leachate piping shall be avoided until there is at least a 12 in. cover of Filter Sand over the completed geotextile envelop. Temporary ramps no steeper than 10H:1V transverse to the piping shall be provided for temporary equipment crossings until the first lift of gypsum is placed.

3.03 ROADWAY CONSTRUCTION

- A. Prepare the roadway subgrade as shown on the plans, in accordance with Section 02200 – Earthwork.
- B. Furnish Geotechnical Fabric for Ground Stabilization in accordance with Section 02373 – Geotextiles.
- C. Furnish Aggregate Base Course, Type B in accordance with Article 351 of the IDOT Standard Specifications for Road and Bridge Construction.

- D. Furnish Aggregate Surface Course, Type B in accordance with Article 402 of the IDOT Standard Specifications for Road and Bridge Construction.

3.04 TESTING

- A. CQA gradation and permeability tests will be made by the Owner's Testing Consultant during the progress of the work as indicated in Appendix 2. The Contractor shall cooperate with the Testing Consultant and allow such tests to be performed.
- B. If tests indicate that an area of granular material or coarse aggregate does not meet the specified requirements, then the Contractor shall remove the material and replace it with suitable material.

3.05 FINISH GRADING

The granular drainage layer shall be fine graded to provide a smooth finish before a CQA survey of the completed portion of the drainage layer is requested. Ruts or erosion damage shall be repaired before placement of the separation geotextile fabric.

3.06 CONSTRUCTION TOLERANCES

The minimum thickness of drainage layer shall be 1 ft.

END OF SECTION 02315

PART 1. GENERAL

1.01 DESCRIPTION

This section pertains to furnishing and installing geotextile fabrics on prepared surfaces.

1.02 RELATED SECTIONS

The following sections contain items which are related to the work in this section:

1. 02300 - Earthwork
2. 02315 - Granular Materials
3. 02800 – HDPE Geomembrane

1.03 REFERENCES

The following references, or cited portions thereof, govern the work:

1. Illinois Department of Transportation (IDOT): Standard Specifications for Road and Bridge Construction, adopted January 1, 2007.
2. American Society for Testing and Materials (ASTM):
 - a. ASTM 3776 (1996; R 2002) Standard Test Method for Mass per Unit Area (Weight) of Fabric;
 - b. ASTM D 3786 (2001) Test Method for Hydraulic Bursting Strength of Textile Fabrics – Diaphragm Bursting Strength Tester Method;
 - c. ASTM D 4533 (2004) Test Method for Trapezoid Tearing Strength of Geotextiles;
 - d. ASTM D 4632 (1991; R 2003) Test Method for Grab Breaking Load and Elongation of Geotextiles;
 - e. ASTM D 4751 (2004) Test Method for Determining Apparent Opening Size of Geotextile;
 - f. ASTM D 4833 (2000) Test Method for Index Puncture Resistance of Geotextiles, Geomembranes, and Related Products;
 - g. ASTM D 4873 (2002) Guide for Identification, Storage, and Handling of Geosynthetic Rolls;
 - h. ASTM D 4884 (1996; R 2003) Test Method for Strength of Sewn or Thermally Bonded Seams of Geotextiles;
 - i. ASTM D5261-92(2003) Standard Test Method for Measuring Mass per Unit Area of Geotextiles

- j. ASTM D6241-04 Standard Test Method for the Static Puncture Strength of Geotextiles and Geotextile-Related Products Using a 50-mm Probe

1.04 MEASUREMENT AND PAYMENT

- A. The Contractor shall be responsible for estimating the extent of geotextile fabric required to complete the work including fabric for laps, anchorage, repairs, and samples for Construction Quality Assurance (CQA) testing. The Contractor shall include the dollar amount associated with all geotextile construction in his Lump Sum Bid amount, except as specified in paragraph B.
- B. Geotextile fabric for ground stabilization, when directed by the Owner's Representative, will be paid for on a time and materials basis.
- C. No additional payment will be made for geotextile fabric for ground stabilization installed at the Contractor's discretion.

1.05 SUBMITTALS

A. Product Data

- 1. The manufacturer's list of guaranteed properties for each geotextile fabric or geogrid proposed for use on the project shall be submitted.
- 2. The manufacturer's installation guidelines shall be submitted.

B. Samples

Samples of geotextile fabrics shall be submitted for CQA prequalification testing. Sample size and sampling frequency are specified in Appendix 2.

C. Inventory

A copy of the roll inventory that identifies, as a minimum, manufacturer or supplier, product or style number, roll number, width, and length of roll as identified on the roll label shall be submitted.

1.06 STORAGE AND HANDLING

Geotextiles shall be stored and handled according to ASTM D4873.

PART 2. PRODUCTS

2.01 MATERIALS

A. Geotextile Fabric for Liner System

Geotextile fabrics for use in the cell liner system shall consist of non-woven filaments of polypropylene, polyester, or polyethylene. Stabilizers and/or inhibitors shall be added to the base polymer if necessary to make the filaments resistant to deterioration caused by ultraviolet light and heat exposure. Reclaimed or recycled fibers or polymer shall not be added to the formulation. Non-woven fabric may be needle-punched, heat-bonded, or a combination thereof. The filaments shall be dimensionally stable (i.e., filaments shall maintain their relative position with respect to each other) and resistant to delamination. The edges of the geotextile shall be finished to prevent the outer fiber from pulling away from the geotextile. The filaments shall be free from any chemical treatment or coating that might significantly reduce porosity and permeability.

Fabric shall have the following physical properties:

Physical Properties⁽¹⁾	4 oz. (Separation)	6 oz. (PWRS)	16 oz. (CA Envelope)
Mass/Unit Area (oz./yd ²) ASTM D5261	4.0	6.0	16.0
Grab Tensile Strength (lb.) ASTM D4632	115	160	380
Grab Elongation (%) ASTM D4632	50	50	50
Puncture Strength (lb.) ASTM D4833	65	85	240
Puncture (CBR) Strength (lb.) ASTM D6241	310	410	1025
Mullen Burst Strength (psi) ASTM D3786	210	280	750
Trapezoidal Tear Strength (lb.) ASTM D4533	50	60	150
Width (ft.)	15	15	15
Apparent Opening Size (AOS) Max. US Std. Sieve No. ASTM D4751	70	70	100
UV Resistance ⁽²⁾ (%) ASTM D4355	70	70	70
Roll Width (ft.)	15	15	15

Notes:

- (1) All Values listed are Minimum Average Roll Values (MARV) unless otherwise noted, calculated as the typical minus two standard deviations.
- (2) UV Resistance is a minimum value and not a MARV. Evaluation to be on 2.0 inch strip tensile specimens after 500 hours exposure.

A. Cushion Geotextile Fabric.

Cushion geotextile fabric shall consist of non-woven filaments of polypropylene, polyester, or polyethylene. Stabilizers and/or inhibitors shall be added to the base polymer if necessary to make the filaments resistant to deterioration caused by ultraviolet light and heat exposure. Reclaimed or recycled fibers or polymer shall not be added to the formulation. Non-woven fabric may be needle-punched, heat-bonded, or a combination thereof. The filaments shall be dimensionally stable (i.e., filaments shall maintain their relative position with respect to each other) and resistant to delamination. The edges of the geotextile shall be finished to prevent the outer fiber from pulling away from the geotextile. The filaments shall be free from any chemical treatment or coating that might significantly reduce porosity and permeability.

Fabric shall have the following physical properties:

Physical Properties⁽¹⁾	10 oz. (Cushion)
Mass per unit area (oz/yd ²) ASTM D5261	10
Grab Tensile Strength (lb.) ASTM D4632	230
Grab Tensile Elongation (%) ASTM D4632	50
Trapezoidal Tear Strength (lb.) ASTM D4533	95
Puncture (CBR) Strength (lb.) ASTM D6241	700
Puncture (CBR) Elongation (in.) ASTM D6241	1.5
UV Resistance ⁽²⁾ (%) ASTM D4355	70
Apparent Opening Size (Max.) (AOS) Sieve No. - ASTM D4751	---
Roll Width (ft.)	15

Notes:

- (1) All Values listed are Minimum Average Roll Values (MARV) unless otherwise noted, calculated as the typical minus two standard deviations.
- (2) UV Resistance is a minimum value and not a MARV. Evaluation to be on 2.0 inch strip tensile specimens after 500 hours exposure.

B. Geotechnical Fabric for Ground Stabilization

Geotechnical fabric for ground stabilization shall conform to Article 1080.02 of the IDOT Standard Specifications for Road and Bridge Construction.

C. Thread for Seams

High strength thread should be used such that seam test should conform to ASTM D4884. The thread shall meet the chemical, ultraviolet, and physical requirements of the geotextile, and the color shall be different from that of the geotextile.

D. Securing Devices

Pins, staples, and other devices that project through the geotextile fabric are not permitted for fabrics installed above the geomembrane. Sandbags, stone, or other appropriate means approved by the Owner's Representative shall be used to prevent movement of the geotextile.

2.02 EQUIPMENT

- A. Equipment for spreading and compacting granular materials shall be low ground pressure equipment to prevent damage to the underlying geosynthetic liners.

PART 3. EXECUTION

3.01 SAMPLES FOR CQA TESTING

- A. Geotextile fabric samples shall be obtained, identified and packaged from rolls designated by the Owner's Representative according to ASTM D4873.
- B. Samples shall be 3 ft. wide by the full roll width.

3.02 BASE PREPARATION

- A. Surface on which the geotextile will be placed shall be prepared to a relatively smooth surface condition, and shall be free from obstruction, debris, depressions, erosion features, or any irregularities that would prevent continuous, intimate contact of the geotextile with the entire surface. Rills, gullies, and ruts must be graded out of the surface before geotextile placement. Areas on which geotextile are to be placed shall be graded and/or dressed in accordance with Section 02200 – Earthwork and Section 02315 – Granular Drainage Materials. Immediately prior to placing the geotextile, the prepared base will be inspected by the Owner's Representative, and no material shall be placed thereon until that area has been approved.
- B. Geotextile cushion fabric will be installed directly on the geosynthetic liner. Jointly inspect the liner with the Owner's Representative before commencing fabric installation each day. Notify the Owner's Representative promptly of any damage or defects observed in the liner as fabric installation progresses. Do not place fabric in the damaged or defective area until the liner has been repaired and

approved by the Owner's Representative. Submit a daily inspection report identifying the area of fabric placement and certifying that there were no visible defects in the area of fabric placement.

- C. Do not run heavy vehicle traffic directly on the geosynthetic liner or cushion geotextile. Use vehicles and equipment as specified in paragraph 2.02 to transport and deploy fabric on the liner. Operate the equipment with care, and place protective cover over the geomembrane, if necessary, to avoid damaging the liner. Route traffic and personnel over installed cushion fabric and use the installed fabric as a working platform to the greatest extent possible.

3.03 INSTALLATION

A. General Requirements:

- 1. Geotextile fabric shall be unrolled and laid out following these requirements to the greatest extent practical:
 - a. Orient panels with the longest dimension parallel to the slope.
 - b. Minimize the number of seams in corners and odd-shaped areas.
 - c. Extend panels on slopes a minimum of 5 ft onto a horizontal surface.

Geotextile panels shall be unrolled using methods that will not damage the fabric and will protect underlying surface from damage. While unrolling, the geotextile fabric shall be visually inspected for imperfections and faulty or suspect areas marked. Ballast shall be placed on fabric to prevent wind uplift. Expansion and contraction should be allowed for by leaving slack.

Heavy vehicle traffic shall not be run directly on geotextile fabric. Fabric in areas of heavy traffic shall be protected with protective cover over the fabric.

2. Laps

Individual panels of geotextile fabric shall be lapped according to manufacturer's instructions and as specified herein. Provide a minimum overlap of 3 in. unless otherwise specified herein or in the plans. Shingle overlaps so that water or other material cannot run down the slope between the two layers of fabric.

3. Field Seams

Continuously sew all laps on slopes steeper than 10H:1V. This requirement does not apply to the heavy geotextile fabric for envelopment of coarse aggregate around leachate piping.

4. Defects and Repairs

Examine the installed geotextile fabric for defects, holes discontinuous seams, puckered or separated laps, etc. Repair defective laps and seams. Patch holes and defects according to manufacturer's recommendations and as directed by the Owner's Representative. Do not cover suspect or patched areas until they have been inspected and approved by the Owner's Representative.

B. Geotextile Fabric for Separation

1. Use low ground pressure equipment to avoid rutting the granular material.
2. Horizontal seams (parallel to top of slope) will be permitted on cell side slopes to facilitate staged construction of the drainage layer on the side slope.
3. Extend separation geotextile fabric into and across the bottom of the anchor trench and complete backfill of the trench according to Section 02200.

C. Geotextile Fabric for Coarse Aggregate Envelope

1. Geotextile for coarse aggregate envelope will be installed directly on the cushion fabric. Remove any foreign materials from the cushion fabric within the footprint of the coarse aggregate leachate piping encasement before installing the geotextile envelope. Place sufficient width to completely envelop the coarse aggregate and provide a longitudinal lap of at least 6 in.
2. After the coarse aggregate encasement has been completed, according to Section 02315, wrap the geotextile around the mounded aggregate, and cover the lap with at least 6 in. of material before permitting vehicle or equipment on the fabric.
3. Any ballast material other than coarse aggregate, according to Section 02315, that is placed within the envelope will require removal during coarse aggregate construction.

D. Geotechnical Fabric for Ground Stabilization

1. Install Geotechnical Fabric for Ground Stabilization in accordance with Section 210 of the IDOT Standard Specifications for Road and Bridge Construction.

2. If approved by the Owner's Representative, the Contractor may, at his own expense, install geotextile or geogrid for ground stabilization outside the limits designated by the Owner's Representative.
3. Submit as-built drawings that clearly delineate limits and type of ground stabilization.

3.04 PROTECTION

- A. Protect installed fabric until it is covered by at least 1 ft. of overlying material.
- B. Any damage to the geotextile during its installation or during placement of overlying materials shall be replaced by the Contractor at no cost to the Owner. Unless otherwise noted, the work shall be scheduled so that the covering of the geotextile with a layer of the specified material is accomplished within 14 calendar days after placement of the geotextile. Failure to comply shall require replacement of geotextile. The geotextile shall be protected from damage prior to and during the placement of overlying materials. Before placement of overlying materials, the Contractor shall demonstrate that the placement technique will not cause damage to the geotextile.

3.05 TESTING AND INSPECTION

A. Prequalification Testing

Geotextiles are subject to CQA testing by the Owner's Testing Consultant to verify conformance with the manufacturer's list of guaranteed properties according to Appendix 2. The Contractor shall provide samples as specified herein. If tests indicate nonconformance to the list of guaranteed properties, provide additional samples as directed by the Owner's Representative to determine the extent of the non-conformance. Any fabric that does not conform to the list of guaranteed properties shall be removed from the site.

- B. Installed fabric shall be inspected by the Owner's Representative. No material shall be placed on the fabric, other than ballast, until the installation has been approved by the Owner's Representative. Ballast shall not obscure seams or significant length of unseamed laps. The Owner's Representative may require removal of ballast to inspect suspect areas.
- C. If the Owner's Representative suspects that completed work has been damaged by construction methods that do not conform to the specifications, he may require removal of completed work to verify the integrity of the underlying materials. The Contractor shall bear the cost of removal and subsequent repair as directed by the Owner's Representative.

END OF SECTION 02373

DIVISION 2 - SITEWORK

Section 02376 – Geosynthetic Clay Liner

PART 1. GENERAL

1.01 DESCRIPTION

- A. This section covers furnishing and installation of a reinforced needlepunched Geosynthetic Clay Liner (GCL) at the Gypsum Management Facility and the CCB Management Facility.
- B. The work includes furnishing all equipment and materials, providing all labor, supervision, administration and management necessary to perform the work as specified herein and as shown on the plans.

1.02 RELATED SECTIONS

None.

1.03 REFERENCES

The following references, or cited portions thereof, govern the work

- 1. American Society for Testing and Materials (ASTM):
 - a. ASTM D 4632 (1991; R 2003), Standard Test Method for Grab Breaking Load and Elongation of Geotextiles;
 - b. ASTM D 4643 (2000), Test Method for Determination of Water (Moisture) Content of Soil by the Microwave Oven Method;
 - c. ASTM D 5084 (2003), Test Method for Measurement of Hydraulic Conductivity of Saturated Porous Materials Using a Flexible Wall Permeameter;
 - d. ASTM D 5261 (1992; R 2003), Test Method for Measuring Mass Per Unit Area of Geotextiles;
 - e. ASTM D 5321 (2002), Test Method for Determining the Coefficient of Soil and Geosynthetic or Geosynthetic and Geosynthetic Friction by the Direct Shear Method;
 - f. ASTM D 5887 (2004), Test Method for Measurement of Index Flux Through Saturated Geosynthetic Clay Liner Specimens Using a Flexible Wall Permeameter;
 - g. ASTM D 5888 (1995; R 2002), Practice for Storage and Handling of Geosynthetic Clay Liners;
 - h. ASTM D 5889 (1997; R 2003), Practice for Quality Control of Geosynthetic Clay Liners;

- i. ASTM D 5890 (2002), Test Method for Swell Index of Clay Mineral Component of Geosynthetic Clay Liners;
- j. ASTM D 5891 (2002), Test Method for Fluid Loss of Clay Component of Geosynthetic Clay Liners.

1.04 SUBMITTALS

- A. With the bid, the Contractor shall furnish the following information:
 1. Conceptual description of the proposed plan for placement of the GCL panels over the areas of installation.
 2. GCL Manufacturer's Quality Control (MQC) Plan for documenting compliance with Sections 2.01 and 2.02 of these specifications.
 3. GCL manufacturer's historical data for reinforced GCL of a) 10,000-hour creep shear testing per Section 2.01 D, and b) seam flow data at 2 psi confining pressure per Section 2.01 E.
 4. A copy of GCL manufacturer's International Standards Organization (ISO) Quality Certificate of Registration.
 5. Statement of experience from the proposed GCL supplier.
 6. Statement of experience from the proposed GCL installer.
- B. At the Owner Representative's or Owner's request, the Contractor shall furnish:
 1. A representative sample of the GCLs.
 2. A project reference list for the GCL(s) consisting of the principal details of at least ten projects totaling at least 10 million sq. ft (100,000 sq. meters) in size.
- C. Upon shipment, the Contractor shall furnish:
 1. The GCL manufacturer's Quality Assurance/Quality Control (QA/QC) certifications to verify that the materials supplied for the project are in accordance with the requirements of this specification.
 2. Inventory of materials received.
- D. As installation proceeds, the Contractor shall submit certificates of subgrade acceptance, signed by the Contractor and Construction Quality Assurance (CQA) Inspector (see Sections 1.06 and 3.03) for each area that is covered by the GCL.
- E. Warranty

After construction, the contractor shall submit material and installation warranty certificates.

1.05 QUALIFICATIONS

- A. GCL Manufacturer must have produced at least 10 million sq. ft. (1 million sq. meters) of GCL, with at least 8 million sq. ft. (800,000 sq. meters) installed.
- B. The GCL Installer must either have installed at least 1 million sq. ft. (100,000 sq. meters) of GCL, **or** must provide to the Engineer satisfactory evidence, through similar experience in the installation of other types of geosynthetics, that the GCL will be installed in a competent, professional manner.

1.06 CONSTRUCTION QUALITY ASSURANCE (CQA)

- A. The Owner shall provide a third-party inspector for CQA of the GCL installation. The inspector shall be an individual or company who is independent from the manufacturer and installer and who shall be responsible for monitoring and documenting activities, related to the CQA of the GCL throughout installation.
- B. Testing of the GCL as necessary to support the CQA effort shall be performed by a third party laboratory retained by the Owner and independent from the GCL manufacturer and installer.

WARRANTY

The geomembrane material shall be warranted, on a pro-rata basis against manufacturer's defects for a period of five (5) years from the date of liner installation. The installation shall be warranted against defects in workmanship for a period of (1) year from the date of liner completion.

PART 2. PRODUCTS

2.01 MATERIALS

- A. Acceptable products for the GCL are GCL Bentomat[®] SDN, as manufactured by CETCO, 1350 West Shure Drive, Arlington Heights, Illinois 60004 USA (847-392-5800), or an engineer-approved reinforced needlepunched GCL material equal to Bentomat SDN.
- B. The delineation of areas to receive GCL shall be agreed by the Installer and the Engineer prior to installation.
- C. The GCL and its components shall have the properties shown in the GCL Certified Properties table at the end of this section.
- D. The reinforced GCL shall have 10,000 hour test data for large-scale constant-load (creep) shear testing for related products under hydrated conditions. The

displacement shall be 0.13 in. (3.3 mm) or less at a constant shear load of 250 psf (12 kPa) and a normal load of 500 psf (24 kPa).

- E. The reinforced GCL shall have seam test data from an independent laboratory showing that the seam flow with a grooved cut in one of the nonwoven geotextiles is less than $1 \times 10^{-8} \text{ m}^3/\text{m}^2/\text{s}$ at 2 psi hydraulic pressure.
- F. The minimum acceptable dimensions of full-size GCL panels shall be 150 ft. (45.7 m) in length. Short rolls [(those manufactured to a length greater than 70 ft. (21 meters) but less than a full-length roll)] may be supplied at a rate no greater than three (3) per truckload or three (3) rolls every 36,000 sq. ft. (3,500 sq. meters) of GCL, whichever is less.
- G. A 6-inch (150 mm) overlap guideline shall be imprinted on both edges of the upper geotextile component of the GCL as a means for providing quality assurance of the overlap dimension. Lines shall be printed in easily visible, non-toxic ink.

2.02 PRODUCT QUALITY DOCUMENTATION

The GCL manufacturer shall provide the Contractor or other designated party with manufacturing QA/QC certifications for each shipment of GCL. The certifications shall be signed by a responsible party employed by the GCL manufacturer and shall include:

- A. Certificates of analysis for the bentonite clay used in GCL production demonstrating compliance with the swell index and fluid loss parameters shown in the GCL Certified Properties tables.
- B. Manufacturer's test data for finished GCL product(s) of bentonite mass/area, GCL tensile strength and GCL peel strength (reinforced only) demonstrating compliance with the index parameters shown in the GCL Certified Properties tables.
- C. GCL lot and roll numbers supplied for the project (with corresponding shipping information).

2.03 PRODUCT LABELING

- A. Prior to shipment, the GCL manufacturer shall label each roll, identifying:
 - 1. Product identification information (Manufacturer's name and address, brand product code).
 - 2. Lot number and roll number.
 - 3. Roll length, width and weight.

2.04 PACKAGING

- A. The GCL shall be wound around a rigid core whose diameter is sufficient to facilitate handling. The core is not necessarily intended to support the roll for lifting but should be sufficiently strong to prevent collapse during transit.
- B. All rolls shall be labeled and bagged in packaging that is resistant to photodegradation by ultraviolet (UV) light.

2.05 ACCESSORY BENTONITE

- A. The granular bentonite sealing clay used for overlap seaming, penetration sealing and repairs shall be made from the same natural sodium bentonite as used in the GCL and shall be as recommended by the GCL manufacturer. Seaming of GCLs shall be conducted in accordance with the manufacturer's guidelines for each particular GCL. Please refer to the installation guidelines for Bentomat /Claymax GCLs.

PART 3. EXECUTION

3.01 SHIPPING AND HANDLING

- A. The rolls of GCL shall be packaged and shipped by appropriate means to prevent damage to the material and to facilitate off-loading.
- B. The Installation Supervisor shall be present during delivery and unloading of the GCL. A visual inspection of each roll should be made during unloading to identify if any packaging has been damaged. Rolls with damaged packaging should be marked and set aside for further inspection. The packaging should be repaired prior to being placed in storage. The Installation Supervisor shall prepare and submit an inventory that includes lot and roll number for materials received.
- C. The Installer is responsible for unloading the GCL. The Owner will make available equipment and operators employed at the site to assist with unloading. The Installer shall coordinate with the Owner to determine equipment availability and should contact the Manufacturer prior to shipment to ascertain the appropriateness of the proposed unloading methods and equipment.

3.02 STORAGE

- A. Storage of the GCL rolls shall be the responsibility of the Installer. A dedicated storage area shall be provided by the Owner at the job site. Submit storage area requirements (size and preferred location) with bid documents.

- B. Rolls should be stored in a manner that prevents sliding or rolling from the stacks and may be accomplished by the use of chock blocks. Rolls should be stacked at a height no higher than that at which the lifting apparatus can be safely handled (typically no higher than four).
- C. All stored GCL materials and the accessory bentonite must be covered with a plastic sheet or tarpaulin until their installation.
- D. The integrity and legibility of the labels shall be preserved during storage.

3.03 EARTHWORK

- A. The low permeability soil layer upon which the GCL is installed shall be prepared and compacted prior to installation. The surface shall be smooth, firm, and unyielding, and free of:
 - 1. Vegetation.
 - 2. Construction debris.
 - 3. Sticks.
 - 4. Sharp rocks.
 - 5. Void spaces.
 - 6. Ice.
 - 7. Abrupt elevation changes.
 - 8. Standing water.
 - 9. Cracks larger than 0.25 in. (6 mm) in width.
 - 10. Any other foreign matter that could contact the GCL.
- B. Immediately prior to GCL deployment, the low permeability soil layer shall be final-graded by the contractor to fill in all voids or cracks and then smooth-rolled to provide the best practicable surface for the GCL. At completion of this activity, no wheel ruts, footprints or other irregularities shall exist in the subgrade. Furthermore, all protrusions extending more than 0.5 in. (12 mm) from the surface shall either be removed, crushed or pushed into the surface with a smooth-drum compactor.
- C. On a continuing basis, the project CQA inspector shall certify acceptance of the subgrade before GCL placement.
- D. It shall be the Installer's responsibility thereafter to indicate to the Owner's Representative any change in the condition of the low permeability soil layer that could cause the subgrade to be out of compliance with any of the requirements listed in this Section. The Installation Supervisor shall certify in the daily report that no GCL was placed over visibly defective low permeability soil surface.
- E. At the top of sloped areas of the job site, an anchor trench for the GCL shall be excavated by the contractor in accordance with the project plans. The trench shall

be excavated and approved by the CQA Inspector prior to GCL placement. No loose soil shall be allowed at the bottom of the trench and no sharp corners or protrusions shall exist anywhere within the trench.

3.04 GCL PLACEMENT

- A. GCL rolls shall be delivered to the working area of the site in their original packaging. Immediately prior to deployment, the packaging shall be carefully removed without damaging the GCL. The orientation of the GCL (i.e., which side faces up) shall be in accordance with the Owner Representative's recommendations.
- B. Equipment which could damage the GCL, shall not be allowed to travel directly on it. If the installation equipment causes rutting of the subgrade, the subgrade must be restored to its originally accepted condition before placement continues.
- C. Care must be taken to minimize the extent to which the GCL is dragged across the subgrade in order to avoid damage to the bottom surface of the GCL. A temporary geosynthetic subgrade covering commonly known as a slip sheet or rub sheet may be used to reduce friction damage during placement.
- D. The GCL panels shall be placed parallel to the direction of the slope.
- E. All GCL panels shall lie flat on the underlying surface, with no wrinkles or folds, especially at the exposed edges of the panels.
- F. Only as much GCL shall be deployed as can be covered at the end of the working day with soil, a geomembrane, or a temporary waterproof tarpaulin. The GCL shall not be left uncovered overnight. If the GCL is hydrated when no confining stress is present, the Installer shall remove and replace the hydrated material as directed by the Owner Representative.

3.05 ANCHORAGE

- A. As directed by the project drawings and specifications, the end of the GCL roll shall be placed in an anchor trench at the top of the slope. The front edge of the trench shall be rounded so as to eliminate any sharp corners. Loose soil shall be removed from the floor of the trench. The GCL shall cover the entire trench floor, but shall not extend up the rear trench wall.

3.06 SEAMING

- A. The GCL seams shall be constructed by overlapping their adjacent edges according to the manufacturer's recommendations. Care should be taken to ensure that the overlap zone is not contaminated with loose soil or other debris.

- B. The minimum dimension of the longitudinal overlap should be 6 in. (150 mm) for Bentomat SDN. If the GCL is manufactured with a grooved cut in the nonwoven geotextile that allows bentonite to freely extrude into the longitudinal overlap then no bentonite-enhanced seam is required for this overlap. If the GCL does not have a grooved cut in one of the nonwoven geotextiles in the longitudinal overlap, then bentonite-enhanced seams are required as described below.
- C. End-of-roll overlapped seams shall be constructed with a minimum overlap of 24 in. (600 mm) for Bentomat SDN. Seams at the ends of the panels should be constructed such that they are shingled in the direction of the grade to prevent the potential for runoff flow to enter the overlap zone. End-of-roll overlapped seams for all reinforced GCL seams require bentonite-enhanced seams as described below.
- D. Bentonite-enhanced seams shall be constructed between the overlapping adjacent panels as follows. The underlying edge of the longitudinal overlap is exposed and then a continuous bead of granular sodium bentonite is applied along a zone defined by the edge of the underlying panel and the 6-inch (150 mm) line. The granular bentonite shall be applied at a minimum application rate of one quarter pound per lineal ft. (0.4 kg/m). A similar bead of granular sodium bentonite is applied at the end-of-roll overlap.

3.07 DETAIL WORK

- A. There shall be no penetrations through the GCL.
- B. Cutting the GCL should be performed using a sharp utility knife. Frequent blade changes are recommended to avoid damage to the geotextile components of the GCL during the cutting process.

3.08 DAMAGE REPAIR

- A. If the GCL is damaged (torn, punctured, perforated, etc.) during installation, it may be possible, if approved by the Owner's Representative, to repair it by cutting a patch to fit over the damaged area. The patch shall be obtained from a new GCL roll and shall be cut to size such that a minimum overlap of 12 in. (300 mm) is achieved around all of the damaged area. Granular bentonite or bentonite mastic shall be applied around the damaged area prior to placement of the patch. It may be desirable to use an adhesive to affix the patch in place so that it is not displaced during cover placement. Patching shall be observed and approved by the Owner's Representative.

GCL CERTIFIED PROPERTIES

MATERIAL PROPERTY	TEST METHOD	TEST FREQUENCY ft ² (m ²)	REQUIRED VALUES
Bentonite Swell Index ¹	ASTM D 5890	1 per 50 tonnes	24 mL/2g min.
Bentonite Fluid Loss ¹	ASTM D 5891	1 per 50 tonnes	18 mL max.
Bentonite Mass/Area ²	ASTM D 5993	40,000 ft ² (4,000 m ²)	0.75 lb/ft ² (3.6 kg/m ²) min
GCL Grab Strength ³	ASTM D 6768	200,000 ft ² (20,000 m ²)	30 lbs/in (53 N/cm) MARV
GCL Peel Strength ³	ASTM D 6496	40,000 ft ² (4,000 m ²)	2.5 lbs/in (4.4 N/cm) min
GCL Index Flux ⁴	ASTM D 5887	Weekly	1 x 10 ⁻⁸ m ³ /m ² /sec max
GCL Hydraulic Conductivity ⁴	ASTM D 5887	Weekly	5 x 10 ⁻⁹ cm/sec max
GCL Hydrated Internal Shear Strength ⁵	ASTM D 5321 ASTM D 6243	Periodic	500 psf (24 kPa) typ @ 200 psf

Notes

¹ Bentonite property tests performed at a bentonite processing facility before shipment to the manufacturer's production facilities.

² Bentonite mass/area reported at 0 percent moisture content.

³ All tensile strength testing is performed in the machine direction using ASTM D 6768. All peel strength testing is performed using ASTM D 6496. Upon request, tensile and peel results can be reported per modified ASTM D 4632 using 4 inch grips.

⁴ Index flux and permeability testing with deaired distilled/deionized water at 80 psi (551kPa) cell pressure, 77 psi (531 kPa) headwater pressure and 75 psi (517 kPa) tailwater pressure. Reported value is equivalent to 925 gal/acre/day. This flux value is equivalent to a permeability of 5x10⁻⁹ cm/sec for typical GCL thickness. Actual flux values vary with field condition pressures. The last 20 weekly values prior the end of the production date of the supplied GCL may be provided.

⁵ Peak values measured at 200 psf (10 kPa) normal stress for a specimen hydrated for 48 hours. Site-specific materials, GCL products, and test conditions must be used to verify internal and interface strength of the proposed design.

END OF SECTION 02376

02376-9

DIVISION 2 - SITE WORK
Section 02640 – HDPE Piping

PART 1. GENERAL

1.01 DESCRIPTION

This section pertains to construction of the HDPE (High Density Polyethylene) Piping at the Gypsum Management Facility and the CCB Management Facility.

1.02 RELATED SECTIONS

None.

1.03 REFERENCES

The following references, or cited portions thereof, govern the work

A. American Society of Testing and Materials:

1. ASTM D 2683 (2004); Specification for Socket-Type Polyethylene Fittings for Outside Diameter-Controlled Polyethylene Pipe and Tubing.
2. ASTM D 3261 (2003); Specification for Butt Heat Fusion Polyethylene (PE) Plastic Fittings for Polyethylene (PE) Plastic Pipe and Tubing.
3. ASTM D 3350 (2005); Specification for Polyethylene Plastics Pipe and Fittings Materials.
4. ASTM F 412 (2001a); Terminology Relating to Plastic Piping System.
5. ASTM F 1055 (1998); Specification for Electrofusion Type Polyethylene Fittings for Outside Diameter Controlled Polyethylene Pipe and Tubing.
6. ASTM F 1056 (2004); Specification for Socket Fusion Tools for Use in Socket Fusion Joining Polyethylene Pipe or Tubing and Fittings.

1.04 SUBMITTALS

A. Qualifications

Submit qualifications of the Welding Supervisor who will be responsible for construction quality control of the pipe joining process.

B. Material Certifications

Submit manufacturer certifications that the pipe provided complies with the requirements herein.

C. Product Data

1. Submit product data and operating instructions for pipe joining equipment.
2. Submit pipe manufacturer's recommended procedures for storing, handling, and installing pipe and fittings.

1.05 QUALIFICATIONS

- A. The Contractor or Subcontractor performing the work under this section shall have in his employ a Welding Supervisor who has completed a minimum of 1,000 ft of pipe joining work using the type of equipment proposed for use in this work. The Welding Supervisor shall be on site at all times during pipe line installation, and shall provide direct supervision over other employees.

1.06 WARRANTY

- A. The pipe and fittings shall be warranted, on a pro-rata basis, against manufacturer's defects for a period of five (5) years from the date of pipe installation. The installation shall be warranted against defects in workmanship for a period of one (1) year from the date of completion of the leachate collection piping system.

PART 2. PRODUCTS

2.01 MATERIALS

A. Pipe

1. Pipe material shall be High Density Polyethylene (HDPE) PE 3408, according to ASTM F412, with a cell class designation of 345464C, according to ASTM D3350. Iron pipe size (IPS) and standard dimension ratio (SDR) shall be as indicated in the plans.
2. Size and spacing of holes in perforated pipe shall be as indicated in the plans.

B. Fittings

1. Fittings shall be made of the same material, and shall have a pressure rating no less than 160 psi. Butt fusion, socket, or electrofusion fittings, according to ASTM D3261, ASTM D2683, and ASTM F1055, respectively, are acceptable.

2.02 EQUIPMENT

02640-2

A. Butt Fusion Machine

The butt fusion machine shall include the following features:

1. Facer with rotating planer block design.
2. Heater faces coated by the manufacturer to prevent molten plastic from adhering to the heater face.
3. Hydraulic-operated jaws suitable for use with the pipe sizes indicated in the plans.

B. Socket Fusion Equipment

Socket fusion heating tools and depth gauges shall be of the same manufacturer, unless they are all marked F1056, indicating compliance with ASTM F1056.

- C. All equipment shall conform to any requirements specified in the pipe and socket manufacturer's installation instructions, and shall be approved by the Owner's Representative.

PART 3. EXECUTION

3.01 MATERIAL DELIVERY, STORAGE, AND HANDLING

- A. HDPE pipe and fittings shall be packaged and shipped by appropriate means to prevent damage to the material and to facilitate off-loading. The Owner will provide an on-site storage site. Storage site requirements (size and preferred location) shall be submitted with the bid documents.
- B. Storage and handling shall be according to manufacturer's recommendations.

3.02 BASE PREPARATION

All HDPE piping shall be installed on a layer of coarse aggregate placed by the Contractor in accordance with the plans. The grade of the coarse aggregate base shall be verified before installing the piping.

3.03 INSTALLATION

All pipe and fittings shall be installed according to the manufacturer's recommendations. Removal of weld beads is not required. Contractor shall place coarse aggregate along the pipe to provide lateral stability. Welds shall not be obscured until they have been approved by the Owner's Representative, the top of pipe shall not be covered until the Construction Quality Assurance (CQA) survey has been completed to verify conformance with specified tolerances.

3.04 INSPECTIONS

- A. The Owner's Representative shall be visually inspect pipe materials to verify that each pipe material is properly stamped (by the manufacturer) for ASTM acceptance before installation. Defective or damaged materials shall be removed from the site.
- B. Each weld and connection shall be visually inspected by the Owner's Representative. Defective welds shall be repaired as directed by the Owner's Representative and according to manufacturer's recommendations. Welds and connections shall not be covered until they have been approved by the Owner's Representative.

3.05 TOLERANCES

- A. HDPE piping shall be located within 0.5 ft. of plan location, and elevation shall be within 0.1 ft. of plan elevation with no adverse slopes.

END OF SECTION 02936

PART 1. GENERAL

1.01 DESCRIPTION

- A. This section includes manufacturing, furnishing, and installing High Density Polyethylene (HDPE) Geomembranes for the Gypsum Management Facility and the Gypsum Management Facility Recycle Pond.
- B. The work includes furnishing all equipment and materials and providing all labor, supervision, administration and management necessary to perform the work as shown on the plans.

1.02 RELATED SECTIONS

- A. The following sections contain items which are related to the work in this section:
 - 1. 02373 – Geotextiles
 - 2. 02376 – Geosynthetic Clay Liner

1.03 REFERENCES

- A. The following references, or cited portions thereof, govern the work:
 - 1. American Society for Testing and Materials (ASTM):
 - a. D 638, Standard Test Method for Tensile Properties of Plastics.
 - b. D 751, Standard Test Methods for Coated Fabrics.
 - c. D 792, Standard Test Methods for Density and Specific Gravity (Relative Density) of Plastics by Displacement.
 - d. D 1004, Standard Test Method for Initial Tear Resistance of Plastic Film and Sheeting.
 - e. D 1204, Standard Test Method for Linear Dimensional Changes of Non Rigid Thermoplastic Sheeting or Film at Elevated Temperature.
 - f. D 1238, Standard Test Method for Flow Rates of Thermoplastics by Extrusion Plastometer.
 - g. D 1505, Standard Test Method for Density of Plastics by Density-Gradient Technique.
 - h. D 1603, Standard Test Method for Carbon Black in Olefin Plastics.
 - i. D 3895, Test Method for Oxidative Induction Time of Polyolefins by Thermal Analysis.
 - j. D 4218, Test Method for Determination of Carbon Black Content in Polyethylene Compounds by the Muffle-Furnace Technique.

02800-1

- k. D 4437, Standard Practice for Determining the Integrity of Field Seams Used in Joining Flexible Polymeric Sheet Geomembranes.
- l. D 4833, Test Method for Index Puncture Resistance of Geotextiles, Geomembranes and Related Products.
- m. D 5199, Standard Test Method for Measuring Nominal Thickness of Smooth Geomembranes.
- n. D 5397, Standard Test Method for Evaluation of Stress Crack Resistance of Polyolefins using Notched Constant Tensile Load Test.
- o. D 5596, Standard Practice for Microscopical Examination of Pigment Dispersion in Plastic Compounds.
- p. D 5641, Standard Practice for Geomembrane Seam Evaluation by Vacuum Chamber.
- q. D 5721, Practice for Air-Oven Aging of Polyolefin Geomembranes.
- r. D 5820, Test Method for Air Testing.
- s. D 5885, Test Method for Oxidative Induction Time of Polyolefin Geosynthetics by High Pressure Differential Scanning Calorimetry.
- t. D 5994, Standard Test Method for Measuring Nominal Thickness of Textured Geomembranes
- u. D 6365, Standard Practice for the Nondestructive Testing of Geomembrane Seams using The Spark Test

2. Geosynthetic Research Institute (GRI):

- a. GRI GM 6, Pressurized Air Channel Test for Dual Seamed Geomembranes
- b. GRI GM 9, Cold Weather Seaming of Geomembranes
- c. GRI GM 10, Specification for Stress Crack Resistance of HDPE Geomembrane Sheet
- d. GRI GM 13, Test Properties, Testing Frequency and Recommended Warranty for High Density Polyethylene (HDPE) Smooth and Textured Geomembranes
- e. GRI GM 14, Test Frequencies for Destructive Seam Testing

1.04 SUBMITTALS

- A. Submit the following to the Engineer or Owner, for review and approval, within a reasonable time so as to expedite shipment or installation of the Geomembrane:
 - 1. Documentation of manufacturer's qualifications as specified in subsection 1.05A of this Section.
 - 2. Manufacturer's Quality Control program manual or descriptive documentation.
 - 3. A material properties sheet, including at a minimum all properties specified in GRI GM 13, including test methods used.
 - 4. Sample of the material.

02800-2

5. Documentation of Installer's qualifications, as specified below and in subsection 1.05B of this Section.
 - a. Submit a list of at least ten completed facilities. For each name and type of facility; its location; the date of installation; number of contact at the facility; type and thickness of geomembrane and; surface area of the installed geomembrane.
 - b. Submit resumes or qualifications of the Installation Supervisor, Master Seamer and Technicians to be assigned to this project.
 - c. Quality Control Program.
6. Example Material Warranty and Liner Installation Warranty complying with subsections 1.07 and 1.08 of this Section.
7. Resin Supplier's name, resin production plant identification, resin brand name and number, production date of the resin, resin Manufacturer's quality control certificates, and certification that the properties of the resin meet the requirements

B. Shop Drawings

1. Submit copies of shop drawings for engineer's approval within a reasonable time so as not to delay the start of geomembrane installation. Shop drawings shall show the proposed panel layout identifying seams and details. Seams should generally follow direction of the slope. Butt seams or roll-end seams should not occur on a slope unless approved by the Owner's Representative. Butt seams on a slope, if allowed, should be staggered.
2. Placement of geomembrane will not be allowed to proceed until Owner's Representative has received and approved the shop drawings.

C. Additional Submittals (In-Progress and at Completion)

1. Manufacturer's warranty (refer to subsection 1.08).
2. Geomembrane installation warranty (refer to subsection 1.09).
3. Daily written acceptance of subgrade surface (refer to subsection 3.01.C).
4. Low-temperature seaming procedures if applicable (refer to subsection 3.03.A)
5. Prequalification test seam samples (refer to subsection 3.05.A.6).
6. Field seam non-destructive test results (refer to subsection 3.05.B.1).
7. Field seam destructive test results (refer to subsection 3.05.C.6).
8. Daily field installation reports (refer to subsection 3.05.G).
9. Installation record drawing, as discussed in subsection 3.05.G).

1.05 QUALITY CONTROL

A. Manufacturer's Qualifications:

The manufacturer of geomembrane of the type specified or similar product shall have at least five years experience in the manufacture of such geomembrane. In addition, the geomembrane manufacturer shall have manufactured at least

10,000,000 sq. ft. of the specified type of geomembrane or similar product during the last five years.

B. Installer's Qualifications:

- 1 The Geomembrane Installer shall be the Manufacturer, approved Manufacturer's Installer or a contractor approved by the Owner's Representative to install the geomembrane.
- 2 The Geomembrane Installer shall have at least three years experience in the installation of the specified geomembrane or similar. The Geomembrane Installer shall have installed at least 10 projects involving a total of 5,000,000 sq. ft. of the specified type of geomembrane or similar during the last three years.
- 3 Installation shall be performed under the direction of a field Installation Supervisor who shall be responsible throughout the geomembrane installation, for geomembrane panel layout, seaming, patching, testing, repairs, and all other activities of the Geomembrane Installer. The Field Installation Supervisor shall have installed or supervised the installation and seaming of a minimum of 10 projects involving a total of 5,000,000 sq. ft. of geomembrane of the type specified or similar product.
- 4 Seaming shall be performed under the direction of a Master Seamer (who may also be the Field Installation Supervisor or Crew Foreman) who has seamed a minimum of 3,000,000 sq. ft. of geomembrane of the type specified or similar product, using the same type of seaming apparatus to be used in the current project. The Field Installation Supervisor and/or Master Seamer shall be present whenever seaming, patching, other welding operations, and testing is performed.
- 5 All seaming, patching, other welding operations, and testing shall be performed by qualified technicians employed by the Geomembrane Installer.

1.06 DELIVERY, STORAGE AND HANDLING

- A. Each roll of geomembrane delivered to the site shall be labeled by the manufacturer. The label shall be firmly affixed and shall clearly state the manufacturer's name, product identification, material thickness, roll number, roll dimensions and roll weight.
- B. Geomembrane shall be protected from mud, dirt, dust, puncture, cutting or any other damaging or deleterious conditions.
- C. Rolls shall be stored away from high traffic areas. Continuously and uniformly support rolls on a smooth, level prepared surface.
- D. Rolls shall not be stacked more than three high.

1.07 PROJECT CONDITIONS

Geomembrane shall not be installed in the presence of standing water, while precipitation is occurring, during excessive winds, or when material temperatures are outside the limits specified in Section 3.03.

1.08 MATERIAL WARRANTY

As required by specification, or as required in GRI GM 13 (attachment A)

1.09 GEOMEMBRANE INSTALLATION WARRANTY

The Geomembrane Installer shall guarantee the geomembrane installation against defects in the installation and workmanship for 1 year commencing with the date of final acceptance.

1.10 GEOMEMBRANE PRE-CONSTRUCTION MEETING

- A. Geomembrane Pre-Construction Meeting shall be held at the site prior to installation of the geomembrane. At a minimum, the meeting shall be attended by the Geomembrane Installer, Owner, Owner's representative (Engineer and/or CQA Firm), and the General Contractor.
- B. Topics for this meeting shall include:
 - 1. Responsibilities of each party.
 - 2. Lines of authority and communication. Resolution of any project document ambiguity.
 - 3. Methods for documenting, reporting and distributing documents and reports.
 - 4. Procedures for packaging and storing archive samples.
 - 5. Review of time schedule for all installation and testing.
 - 6. Review of panel layout and numbering systems for panels and seams including details for marking on geomembrane.
 - 7. Procedures and responsibilities for preparation and submission of as-built panel and seam drawings.
 - 8. Temperature and weather limitations. Installation procedures for adverse weather conditions. Defining acceptable subgrade, geomembrane, or ambient moisture and temperature conditions for working during liner installation.
 - 9. Subgrade conditions, dewatering responsibilities and subgrade maintenance plan.
 - 10. Deployment techniques including allowable subgrade for the geomembrane.
 - 11. Plan for controlling expansion/contraction and wrinkling of the geomembrane.
 - 12. Covering of the geomembrane and cover soil placement.
 - 13. Measurement and payment schedules.
 - 14. Health and safety.
- C. The meeting shall be documented by the Owner's Representative and minutes shall be transmitted to all parties.

PART 2. PRODUCTS

2.01 SOURCE QUALITY CONTROL

Manufacturing Quality Control

- A. The test methods and frequencies used by the manufacturer for quality control/quality assurance of the above geomembrane prior to delivery, shall be in accordance with GRI GM 13, or modified as required for project specific conditions.
- B. The manufacturer's geomembrane quality control certifications, including results of quality control testing of the products, as specified in subsection 2.01.C of this Section, must be supplied to the Owner's Representative. The certification shall be signed by a responsible party employed by the manufacturer, such as the QA/QC Manager, Production Manager, or Technical Services Manager. Certifications shall include lot and roll numbers and corresponding shipping information.
- C. The Manufacturer will provide Certification that the geomembrane and welding rod supplied for the project have the same base resin and material properties.

2.02 GEOMEMBRANE

- A. The geomembrane shall consist of new, first quality products designed and manufactured specifically for the purpose of this work which shall have been satisfactorily demonstrated by prior testing to be suitable and durable for such purposes. The geomembrane rolls shall be seamless, high density polyethylene (HDPE- Density >0.94g/cm) containing no plasticizers, fillers or extenders and shall be free of holes, blisters or contaminants, and leak free verified by 100% in line spark or equivalent testing. The geomembrane shall be supplied as a continuous sheet with no factory seams in rolls. The geomembrane will meet the property requirements as shown in Table A. (GRI GM 13)
- B. Material shall be reviewed for conformance to the project specifications by the Owner's Representative
- C. The geomembrane seams shall meet the property requirements as shown in Table 2, (Attachment B).

PART 3. EXECUTION

3.01 SUBGRADE PREPARATION

- A. Geomembrane installed over geosynthetic clay liner (GCL).

The area of GCL to be covered with geomembrane shall be jointly inspected daily with the Owner's Representative before commencing geomembrane installation for the day, and the condition of the GCL shall be continuously observed as geomembrane installation progresses. Rocks, stones, sticks, sharp objects and debris of any kind shall be removed from the surface of the GCL. The Owner's Representative shall be notified of any discontinuities, premature hydration, or

otherwise defective GCL. Geomembrane shall not be placed over suspect areas until they have been repaired to the satisfaction of the Owner's Representative. The Installation Supervisor shall certify daily in writing that the GCL surface was acceptable at the time of geomembrane installation.

B. Geomembrane installed over cushion dirt.

The area of cushion dirt to be covered with geomembrane shall be prepared in accordance with the Section 02200 – Earthwork. The surface shall be smooth and free of ruts and holes, rocks, stones, sticks, sharp objects and debris of any kind.

C. The Geomembrane installer shall provide daily written acceptance for the surface to be covered by the geomembrane in that day's operations. The surface shall be maintained in a manner, during geomembrane installation, to ensure subgrade suitability.

D. All subgrade damaged by construction equipment and deemed unsuitable by the Owner's Representative for geomembrane deployment shall be repaired prior to placement of the geomembrane. All repairs shall be reviewed by the Owner's Representative and approved by the Geomembrane Installer. This damage, repair, and the responsibilities of the contractor and Geomembrane Installer shall be defined in the preconstruction meeting.

3.02 GEOMEMBRANE PLACEMENT

A. No geomembrane shall be deployed until the applicable certifications and quality control certificates listed in subsection 1.04 of this Section are submitted to and approved by the Owner's Representative. Should geomembrane material be deployed prior to approval by the Owner's Representative it will be at the sole risk of the Geomembrane Installer and/or Contractor. If the material does not meet project specifications it shall be removed from the work area at no cost to the owner.

B. The geomembrane shall be installed to the limits shown on the project drawings and essentially as shown on approved panel layout drawings.

C. No geomembrane material shall be unrolled and deployed if the material temperatures are lower than 0 degrees C (32 degrees F). Temperature limitations should be defined in the preconstruction meeting. Typically, only the quantity of geomembrane that will be anchored and seamed together in one day should be deployed.

D. No vehicular traffic shall travel on the geomembrane other than an approved low ground pressure All Terrain Vehicle or equivalent.

E. Sand bags or equivalent ballast shall be used as necessary to temporarily hold the geomembrane material in position under the foreseeable and reasonably - expected wind conditions. Sand bag material shall be sufficiently close-knit to prevent soil fines from working through the bags and discharging on the geomembrane.

F. Geomembrane placement shall not be done if moisture prevents proper subgrade preparation, panel placement, or panel seaming. Moisture limitations

02800-7

- should be defined in the preconstruction meeting.
- G. Damaged panels or portions of the damaged panels which have been rejected shall be marked and their removal from the work area recorded.
 - H. The geomembrane shall not be allowed to "bridge over" voids or low areas in the subgrade. In these areas, the subgrade shall be prepared to allow the geomembrane to rest in intimate contact with the subgrade.
 - I. Wrinkles caused by panel placement or thermal expansion should be minimized in accordance with section 1.10 B. 11.
 - J. Considerations on Site Geometry: In general, seams shall be oriented parallel to the line of the maximum slope. In corners and odd shaped geometric locations, the total length of field seams shall be minimized. Seams shall not be located at low points in the subgrade.
 - K. Overlapping: The panels shall be overlapped prior to seaming to whatever extent is necessary to effect a good weld and allow for proper testing. In no case shall this overlap be less than 75mm (3 in.).

3.03 SEAMING PROCEDURES

- A. Cold weather installations should follow guidelines as outlined in GRI GM9.
- B. No geomembrane material shall be seamed when liner temperatures are less than 0 degrees C (32 degrees F).
- C. No geomembrane material shall be seamed when the sheet temperature is above 75 degrees C (170 degrees F) as measured by an infrared thermometer or surface thermocouple.
- D. Seaming shall primarily be performed using automatic fusion welding equipment and techniques. Extrusion welding shall be used where fusion welding is not possible such as at pipe penetrations, patches, repairs and short (less than a roll width) runs of seams.
- E. Fishmouths or excessive wrinkles at the seam overlaps, shall be minimized and when necessary cut along the ridge of the wrinkles back into the panel so as to effect a flat overlap. The cut shall be terminated with a keyhole cut (nominal 10 mm (1/2 in) diameter hole) so as to minimize crack/tear propagation. The overlay shall subsequently be seamed. The key hole cut shall be patched with an oval or round patch of the same base geomembrane material extending a minimum of 150 mm (6 in.) beyond the cut in all directions.

3.04 PIPE AND STRUCTURE PENETRATION SEALING SYSTEM

- A. Provide penetration sealing system as shown in the Project Drawings.
- B. Penetrations shall be constructed from the base geomembrane material, flat stock, prefabricated boots and accessories as shown on the Project Drawings. The prefabricated or field fabricated assembly shall be field welded to the geomembrane as shown on the Project Drawings so as to prevent leakage. This assembly shall be tested as outlined in section 3.05.B. Alternatively, where field non destructive testing can not be performed, attachments will be field spark tested by standard holiday leak detectors in accordance with ASTM 6365 Spark testing should be done in areas where both air pressure testing and vacuum testing are not possible.
 - 1. Equipment for Spark testing shall be comprised of but not limited to: A

02800-8

hand held holiday spark tester and conductive wand that generates a high voltage.

2. The testing activities shall be performed by the Geomembrane Installer by placing an electrically conductive tape or wire beneath the seam prior to welding. A trial seam containing a non welded segment shall be subject to a calibration test to ensure that such a defect (non welded segment) will be identified under the planned machine settings and procedures. Upon completion of the weld, enable the spark tester and hold approximately 25mm (1 in) above the weld moving slowly over the entire length of the weld in accordance with ASTM 6365. If there is no spark the weld is considered to be leak free.
3. A spark indicates a hole in the seam. The faulty area shall be located, repaired and retested by the Geomembrane Installer.
4. Care should be taken if flammable gases are present in the area to be tested.

3.05 FIELD QUALITY CONTROL

The Owner's Representative shall be notified prior to all pre qualification and production welding and testing, or as agreed upon in the pre construction meeting.

A. Prequalification Test Seams

1. Test seams shall be prepared and tested by the Geomembrane Installer to verify that seaming parameters (speed, temperature and pressure of welding equipment) are adequate.
2. Test seams shall be made by each welding technician and tested in accordance with ASTM D 4437 at the beginning of each seaming period. Test seaming shall be performed under the same conditions and with the same equipment and operator combination as production seaming. The test seam shall be approximately 3.3 meters (10 feet) long for fusion welding and 1 meter (3 feet) long for extrusion welding with the seam centered lengthwise. At a minimum, tests seams should be made by each technician 1 time every 4-6 hours; additional tests may be required with changes in environmental conditions.
3. Two 25 mm (1 in) wide specimens shall be die-cut by the Geomembrane Installer from each end of the test seam. These specimens shall be tested by the Geomembrane Installer using a field tensiometer testing both tracks for peel strength and also for shear strength. Each specimen shall fail in the parent material and not in the weld, "Film Tear Bond"(F.T.D. failure). Seam separation equal to or greater than 10% of the track width shall be considered a failing test.
4. The minimum acceptable seam strength values to be obtained for all specimens tested are listed in Subsection 3.05.C.4 of this Section. All four specimens shall pass for the test seam to be a passing seam.
5. If a test seam fails, an additional test seam shall be immediately conducted. If the additional test seam fails, the seaming apparatus shall be rejected and not used for production seaming until the deficiencies are

02800-9

corrected and a successful test seam can be produced.

6. A sample from each test seam shall be labeled. The label shall indicate the date, geomembrane temperature, number of the seaming unit, technician performing the test seam and pass or fail description. The sample shall then be given to the Owner's Representative for archiving.

B. Field Seam Non-destructive Testing

1. All field seams shall be non-destructively tested by the Geomembrane Installer over the full seam length before the seams are covered. Each seam shall be numbered or otherwise designated. The location, date, test unit, name of tester and outcome of all non-destructive testing shall be recorded and submitted to the Owner's Representative.
2. Testing should be done as the seaming work progresses, not at the completion of all field seaming. All defects found during testing shall be numbered and marked immediately after detection. All defects found should be repaired, retested and remarked to indicate acceptable completion of the repair.
3. Non-destructive testing shall be performed using vacuum box, air pressure or spark testing equipment.
4. Non-destructive tests shall be performed by experienced technicians familiar with the specified test methods. The Geomembrane Installer shall demonstrate to the Owner's Representative all test methods to verify the test procedures are valid.
5. Extrusion seams shall be vacuum box tested by the Geomembrane Installer in accordance with ASTM D 4437 and ASTM D 5641 with the following equipment and procedures:
 - a. Equipment for testing extrusion seams shall be comprised of but not limited to: a vacuum box assembly consisting of a rigid housing, a transparent viewing window, a soft rubber gasket attached to the base, port hole or valve assembly and a vacuum gauge; a vacuum pump assembly equipped with a pressure controller and pipe connections; a rubber pressure/vacuum hose with fittings and connections; a plastic bucket; wide paint brush or mop; and a soapy solution.
 - b. The vacuum pump shall be charged and the tank pressure adjusted to approximately 35 kPa (5 psig).
 - c. The Geomembrane Installer shall create a leak tight seal between the gasket and geomembrane interface by wetting a strip of geomembrane approximately 0.3m (12 in) by 1.2m (48 in) (length and width of box) with a soapy solution, placing the box over the wetted area, and then compressing the box against the geomembrane. The Geomembrane Installer shall then close the bleed valve, open the vacuum valve, maintain initial pressure of approximately 35 kPa (5 psig) for approximately 5 seconds. The geomembrane should be continuously examined through the viewing window for the presence of soap bubbles, indicating a leak. If no bubbles appear after 5 seconds, the area shall be

- considered leak free. The box shall be depressurized and moved over the next adjoining area with an appropriate overlap and the process repeated.
- d. All areas where soap bubbles appear shall be marked, repaired and then retested.
 - e. At locations where seams cannot be non destructively tested, such as pipe penetrations, alternate nondestructive spark testing (as outlined in section 3.04.B) or equivalent should be substituted.
 - f. All seams that are vacuum tested shall be marked with the date tested, the name of the technician performing the test and the results of the test.
6. Double Fusion seams with an enclosed channel shall be air pressure tested by the Geomembrane Installer in accordance with ASTM D 5820 and ASTM D 4437 and the following equipment and procedures:
- a. Equipment for testing double fusion seams shall be comprised of but not limited to: an air pump equipped with a pressure gauge capable of generating and sustaining a pressure of 210 kPa (30 psig), mounted on a cushion to protect the geomembrane; and a manometer equipped with a sharp hollow needle or other approved pressure feed device.
 - b. The Testing activities shall be performed by the Geomembrane Installer. Both ends of the seam to be tested shall be sealed and a needle or other approved pressure feed device inserted into the tunnel created by the double wedge fusion weld. The air pump shall be adjusted to a pressure of 210 kPa (30 psig), and the valve closed,. Allow 2 minutes for the injected air to come to equilibrium in the channel, and sustain pressure for 5 minutes. If pressure loss does not exceed 28 kPa (4 psig) after this five minute period the seam shall be considered leak tight. Release pressure from the opposite end verifying pressure drop on needle to ensure testing of the entire seam. The needle or other approved pressure feed device shall be removed and the feed hole sealed.
 - c. If loss of pressure exceeds 28 kPa (4 psig) during the testing period or pressure does not stabilize, the faulty area shall be located, repaired and retested by the Geomembrane Installer.
 - d. Results of the pressure testing shall be recorded on the liner at the seam tested and on a pressure testing record.

C. Destructive Field Seam Testing

1. One destructive test sample per 150 linear m (500 linear ft) seam length or another predetermined length in accordance with GRI GM 14 shall be taken by the Geomembrane Installer from a location specified by the Owner's Representative. The Geomembrane Installer shall not be informed in advance of the sample location. In order to obtain test results prior to completion of geomembrane installation, samples shall be cut by the Geomembrane Installer as directed by the Owner's Representative as seaming progresses.

02800-11

2. All field samples shall be marked with their sample number and seam number. The sample number, date, time, location, and seam number shall be recorded. The Geomembrane Installer shall repair all holes in the geomembrane resulting from obtaining the seam samples. All patches shall be vacuum box tested or spark tested. If a patch cannot be permanently installed over the test location the same day of sample collection, a temporary patch shall be tack welded or hot air welded over the opening until a permanent patch can be affixed.
3. The destructive sample size shall be 300 mm (12 in) wide by 1 m (36 in) long with the seam centered lengthwise. The sample shall be cut into three equal sections and distributed as follows: one section given to the Owner's Representative as an archive sample; one section given to the Owner's Representative for laboratory testing as specified in paragraph 5 below; and one section retained by the Geomembrane Installer for field testing as specified in paragraph 4 below.
4. For field testing, the Geomembrane Installer shall cut 10 identical 25 mm (1 in) wide replicate specimens from his sample. The Geomembrane Installer shall test five specimens for seam shear strength and five for peel strength. Peel tests will be performed on both inside and outside weld tracks. To be acceptable, 4 of 5 test specimens must pass the stated criteria in section 2.02 with less than 10% separation. If 4 of 5 specimens pass, the sample qualifies for testing by the testing laboratory if required.
5. If independent seam testing is required by the specifications it shall be conducted in accordance with ASTM 5820 or ASTM D4437 or GRI GM 6.
6. Reports of the results of examinations and testing shall be prepared and submitted to the Owner's Representative.
7. For field seams, if a laboratory test fails, that shall be considered as an indicator of the possible inadequacy of the entire seamed length corresponding to the test sample. Additional destructive test portions shall then be taken by the Geomembrane Installer at locations indicated by the Engineer, typically 3 m (10 ft) on either side of the failed sample and laboratory seam tests shall be performed. Passing tests shall be an indicator of adequate seams. Failing tests shall be an indicator of non-adequate seams and all seams represented by the destructive test location shall be repaired with a cap-strip extrusion welded to all sides of the capped area. All cap-strip seams shall be non-destructively vacuum box tested until adequacy of the seams is achieved. Cap strip seams exceeding 50 M in length (150 FT) shall be destructively tested.

D. Identification of Defects

1. Panels and seams shall be inspected by the Installer and Owner's Representative during and after panel deployment to identify all defects, including holes, blisters, undispersed raw materials and signs of contamination by foreign matter.

E. Evaluation of Defects: Each suspect location on the liner (both in geomembrane
02800-12

seam and non-seam areas) shall be non-destructively tested using one of the methods described in Section 3.05.B. Each location which fails non-destructive testing shall be marked, numbered, measured and posted on the daily "installation" drawings and subsequently repaired.

1. If a destructive sample fails the field or laboratory test, the Geomembrane Installer shall repair the seam between the two nearest passed locations on both sides of the failed destructive sample location.
 2. Defective seams, tears or holes shall be repaired by reseaming or applying a extrusion welded cap strip.
 3. Reseaming may consist of either:
 - a. Removing the defective weld area and rewelding the parent material using the original welding equipment; or
 - b. Reseaming by extrusion welding along the overlap at the outside seam edge left by the fusion welding process.
 4. Blisters, larger holes, and contamination by foreign matter shall be repaired by patches and/or extrusion weld beads as required. Each patch shall extend a minimum of 150 mm (6 in) beyond all edges of the defects.
 5. All repairs shall be measured, located and recorded.
- F. Verification of Repairs on Seams: Each repair shall be non-destructively tested using either vacuum box or spark testing methods. Tests which pass the non-destructive test shall be taken as an indication of a successful repair. Failed tests shall be reseamed and retested until a passing test results. The number, date, location, technician and test outcome of each patch shall be recorded.
- G. Daily Field Installation Reports: At the beginning of each day's work, the Installer shall provide the Engineer with daily reports for all work accomplished on the previous work day. Reports shall include the following:
1. Total amount and location of geomembrane placed;
 2. Total length and location of seams completed, name of technicians doing seaming and welding unit numbers;
 3. Drawings of the previous day's installed geomembrane showing panel numbers, seam numbers and locations of non-destructive and destructive testing;
 4. Results of pre-qualification test seams;
 5. Results of non-destructive testing; and
 6. Results of vacuum testing of repairs.
- H. Destructive test results shall be reported prior to covering of liner or within 48 hours.

3.06 LINER ACCEPTANCE

- A. Geomembrane liner will be accepted by the Owner's Representative when:
1. The entire installation is finished or an agreed upon subsection of the installation is finished;

2. All Installer's QC documentation is completed and submitted to the owner
3. Verification of the adequacy of all field seams and repairs and associated geomembrane testing is complete.

3.07 ANCHOR TRENCH

- A. Construct as specified on the project drawings.

3.08 DISPOSAL OF SCRAP MATERIALS

- A. On completion of installation, the Geomembrane Installer shall dispose of all trash and scrap material in a location approved by the Owner, remove equipment used in connection with the work herein, and shall leave the premises in a neat acceptable manner. No scrap material shall be allowed to remain on the geomembrane surface.

PART 4. GRI GM13 SPECIFICATIONS

Geosynthetics Research Institute (GRI) Test Method GM13 – “Test Methods, Test Properties and Testing Frequency for High Density Polyethylene (HDPE) Smooth and Textured Geomembranes”, Revision 8, Dated July 10, 2006.

ATTACHMENT A:

Minimum Average Weld Properties for Smooth and Textured HDPE Geomembranes (English units)								
Property	Test Method	30 mil	40 mil	50 mil	60 mil	80 mil	100 mil	120 mil
Peel strength (fusion & extrusion) lb/in.	ASTM 4437	39	52	65	78	104	130	156
Shear strength (fusion & extrusion) lb/in.	ASTM 4437	60	80	100	120	160	200	239

END OF SECTION 02800

DIVISION 2 - SITE WORK

Section 02936 - Topsoil, Seeding, and Mulching

PART 1. GENERAL

1.01 DESCRIPTION

This section pertains to seeding and placing mulch or erosion control blanket over seeded areas.

1.02 RELATED SECTIONS

A. Specified elsewhere:

1. 02200 - Earthwork

1.03 REFERENCES

The following reference or cited portions thereof, current at date of bidding documents unless otherwise specified, governs the work.

- A. Illinois Department of Transportation (IDOT): Standard Specifications for Road and Bridge Construction, adopted January 1, 2007.

1.04 SPECIFICATIONS

- A. Work shall conform to the applicable requirements of Sections 250 and 251 of Standard Specifications for Road and Bridge Construction and to the requirements hereinafter specified.
- B. Exceptions: All references in the IDOT specifications to methods of measurement and payment shall not apply.

1.05 WARRANTY

- A. Warranty for one (1) year plus one growing season from date of substantial completion shall be provided.

PART 2. PRODUCTS

2.01 MATERIALS

- A. Seed: Seed shall conform to Article 1081.04 of the IDOT Standard Specifications. The composition of the Ameren Energy Resources Generating hay seeding mix shall

be as follows:

<u>Seed Type</u>	<u>Pounds/Acre</u>
Vernal Alfalfa	12
Wrangler Alfalfa	8
Medium Red Clover	6
Timothy	4

- B. Mulch Material and Erosion Control Blanket: Mulch material shall conform to Article 1081.06 and the excelsior blanket/knitted straw mat shall conform to Article 1081.10 of the IDOT Standard Specifications.
- C. Fertilizer and agricultural ground limestone will not be permitted.

PART 3. EXECUTION

3.01 CONSTRUCTION

- A. Seed bed preparation and seeding methods shall conform to Section 250 of the IDOT Specifications. Seeding of areas disturbed by construction activities after September 30, 2008 may be deferred until Spring 2009.
- B. Seed shall be applied to the perimeter berm ditch, to disturbed portions of the perimeter berm, and to all disturbed earth surfaces outside of the existing perimeter berm. IDOT seeding mixture 7 shall be used on stockpiles. IDOT seeding mixture 1A shall be used on the gypsum stack perimeter earthen berm, the recycle pond dam embankment and on slopes that are 4H:1V or steeper. The Ameren hay seed mix shall be used on slopes flatter than 4H:1V.
- C. Application rates for IDOT seed mixtures shall be as specified in Section 250 of the IDOT Specifications. The application rate for the Ameren Energy Resources Generating's seed mix shall be as specified in the Ameren Energy Resources Generating's hay seeding mix.
- D. Seeded areas shall be mulched in accordance with Article 251.03. The Contractor may use either Method 2 or Method 3.

3.02 MAINTENANCE OF COMPLETED WORK

- A. All areas seeded by the Contractor shall be maintained by the Contractor during the period between completion of such work and final completion and acceptance of the Contractor's work by the Owner. This maintenance shall be such that the completed work, at time of acceptance, complies in all respects with the requirements herein specified.

- B. The areas seeded will be required to germinate. If the seed does not germinate, the Contractor will be required to regrade and reseed at no additional cost.

END OF SECTION 02936

DIVISION 3 - CONCRETE

Section 03100 - Concrete Formwork

PART 1. GENERAL

1.01 WORK INCLUDES

- A. The complete installation of the formwork for cast-in-place concrete, with shoring, bracing and anchorage, openings for other work, form accessories, form stripping.

1.02 RELATED SECTIONS

- A. Section 03200 - Concrete Reinforcement.
- B. Section 03300 - Cast-In-Place Concrete.
- C. Section 03400 - Concrete Embedment Liner.

1.03 REFERENCES

- A. ACI 347 - Recommended Practice For Concrete Formwork.
- B. ACI 301 - Specifications For Structural Concrete For Buildings.

1.04 DESIGN REQUIREMENTS

- A. Design, engineer and construct formwork, shoring and bracing to conform to design and code requirements; resultant concrete to conform to required shape, line and dimension.

1.05 QUALITY ASSURANCE

- A. Perform Work in accordance with ACI 347 and 301.

1.06 REGULATORY REQUIREMENTS

- A. Conform to applicable code for design, fabrication, erection and removal of formwork.

1.07 DELIVERY, STORAGE, AND HANDLING

- A. Store off ground in ventilated and protected manner to prevent deterioration from moisture.

1.08 COORDINATION

- A. Coordinate this Section with other Sections of work which require attachment of components of formwork.
- B. If formwork is placed which results in insufficient concrete cover over reinforcement, request instructions from Owner's Representative before proceeding.

PART 2. PRODUCTS

2.01 WOOD FORM MATERIALS

- A. Softwood Plywood: 3/4 in. PS 1-83 "B-B" (concrete form) plywood, Class I, exterior grade or better, mill-oiled and edge sealed with each piece bearing legible inspection trademark.
- B. Architectural Plywood: 3/4 in. PS 1-83 "B-B" plyform, Class I, with High Density smooth overlay, 1 surface, edge sealed with each piece bearing legible inspection trademark.

2.02 MANUFACTURERS - PREFABRICATED FORMS

- A. Weyerhaeuser Concrete Form.
- B. Georgia Pacific, G-P Exterior Soft Wood Plywood Product.
- C. Plywood and Door Corporation's Finn-Form.

2.03 PREFABRICATED FORMS

- A. Preformed Steel Forms: Minimum 16 gage matched, tight fitting, stiffened to support weight of concrete without deflection detrimental to tolerances and appearance of finished surfaces.
- B. Glass Fiber Fabric Reinforced Plastic Forms: Matched, tight fitting, stiffened to support weight of concrete without deflection detrimental to tolerances and appearance of finished concrete surfaces.

2.04 FORMWORK ACCESSORIES

- A. Form Ties: Snap-off type, galvanized metal, adjustable length, 1 in. back break dimension, free of defects that could leave holes larger than 1 in. in concrete surface; Dayton-Sure Grip snap-in-form ties, as manufactured by Dayton Superior

Corp., Symons Ties as manufactured by Symons Corporation, Snap-Tys as manufactured by Richmond Corporation. Ties shall be removed after forms are removed, and holes filled with mortar that matches the adjacent surfaces.

- B. Form Release Agent: Colorless mineral oil which will not stain concrete, or absorb moisture; by Magic Kote manufactured by Symons Manufacturing Co., Form Coat manufactured by Concrete Services Co., Formcel manufactured by Lambert Corp.
- C. Corners: Chamfered, wood strip type; 3/4 x 3/4 in. size on all exterior corners, 3 x 3 in. size where shown on the drawings; maximum possible lengths.
- D. Nails, Spikes, Lag Bolts, Through Bolts, Anchorages: Sized as required, of sufficient strength and character to maintain formwork in place while placing concrete.
- E. Concrete Embedment Liner, where required, shall be installed in accordance with Section 03400 – Concrete Embedment Liner.

PART 3. EXECUTION

3.01 EXAMINATION

- A. Verify lines, levels and centers before proceeding with formwork. Ensure that dimensions agree with drawings.

3.02 EARTH FORMS

- A. Earth forms are not permitted, except for footings.

3.03 ERECTION - FORMWORK

- A. Erect formwork, shoring and bracing to achieve design requirements, in accordance with requirements of ACI 301. Metal forms shall be installed in strict accordance with manufacturer's directions and specifications.
- B. Provide bracing to ensure stability of formwork. Shore or strengthen formwork subject to overstressing by construction loads.
- C. Arrange and assemble formwork to permit dismantling and stripping. Do not damage concrete during stripping. Permit removal of remaining principal shores.
- D. Align joints and make watertight. Keep form joints to a minimum.
- E. Obtain approval before framing openings in structural members which are not indicated on drawings.

3.04 APPLICATION - FORM RELEASE AGENT

- A. Apply form release agent on formwork in accordance with manufacturer's recommendations.
- B. Apply prior to placement of reinforcing steel, anchoring devices, and embedded items.
- C. Do not apply form release agent where concrete surfaces will receive special finishes or applied coverings which are affected by agent.

3.05 INSERTS, EMBEDDED PARTS, AND OPENINGS

- A. Provide formed openings where required for items to be embedded in or passing through concrete work.
- B. Locate and set in place items which will be cast directly into concrete.
- C. Coordinate work of other Sections in forming and placing openings, slots, reglets, recesses, chases, sleeves, bolts, anchors, and other inserts.
- D. Install accessories in accordance with manufacturer's instructions, straight, level, and plumb. Ensure items are not disturbed during concrete placement.
- E. Provide temporary ports or openings in formwork where required to facilitate cleaning and inspection. Locate openings at bottom of forms to allow flushing water to drain.
- F. Close temporary openings with tight fitting panels, flush with inside face of forms, and neatly fitted so joints will not be apparent in exposed concrete surfaces.

3.06 FORM CLEANING

- A. Clean and remove foreign matter within forms as erection proceeds.
- B. Clean formed cavities of debris prior to placing concrete.
- C. Flush with water or use compressed air to remove remaining foreign matter. Ensure that water and debris drain to exterior through clean-out ports.
- D. During cold weather, remove ice and snow from within forms. Do not use de-icing salts or water to clean out forms. Use compressed air or other means to remove foreign matter.

3.07 FORMWORK TOLERANCES

- A. Construct formwork to maintain tolerances required by ACI 301.

3.08 FIELD QUALITY CONTROL

- A. Inspect erected formwork, shoring, and bracing to ensure that work is in accordance with formwork design, and that supports, fastenings, wedges, ties, and items are secure.
- B. Do not reuse wood formwork more than three times for concrete surfaces to be exposed to view. Do no patch formwork.

3.09 FORM REMOVAL

- A. Do not remove forms or bracing until concrete has gained sufficient strength to carry its own weight and imposed loads.
- B. Loosen forms carefully. Do not wedge pry bars, hammers, or tools against finished concrete surfaces scheduled for exposure to view.
- C. Store removed forms in manner that surfaces to be in contact with fresh concrete will not be damaged. Discard damaged forms.

END OF SECTION 03100

DIVISION 3 - CONCRETE
Section 03200 - Concrete Reinforcement

PART 1. GENERAL

1.01 WORK INCLUDES

- A. The complete installation of the reinforcing steel bars and accessories for cast-in-place concrete.

1.02 RELATED SECTIONS

- A. Section 03100 - Concrete Formwork.
- B. Section 03300 - Cast-in-Place Concrete.

1.03 REFERENCES

- A. ACI 301 - Structural Concrete for Buildings.
- B. ACI 318 - Building Code Requirements For Reinforced Concrete.
- C. ACI SP-66 - American Concrete Institute - Detailing Manual.
- D. ASTM A615 - Deformed and Plain Billet Steel Bars for Concrete Reinforcement.
- E. CRSI - Concrete Reinforcing Steel Institute Manual of Practice.

1.04 SUBMITTALS

- A. Submit under provisions of Section 01010.
- B. Shop Drawings: Indicate bar sizes, spacings, locations, and quantities of reinforcing steel, and bending and cutting schedules. Contract drawings shall not be reproduced as the basis for shop drawings.
- C. Manufacturer's Certificate: Certify that products meet or exceed specified requirements.

1.05 QUALITY ASSURANCE

- A. Perform Work in accordance with CRSI Manual of Standard Practice.
- B. Submit certified copies of mill test report of reinforcement materials analysis.

03200-1

1.06 COORDINATION

- A. Coordinate with placement of formwork, formed openings and other work.

PART 2. PRODUCTS

2.01 REINFORCEMENT

- A. Reinforcing Steel: ASTM A615, 60 ksi yield grade; deformed billet steel bars.

2.02 ACCESSORY MATERIALS

- A. Tie Wire: Minimum 16 gage, annealed steel wire, epoxy coated when used with epoxy-coated reinforcement.
- B. Chairs, Bolsters, Bar Supports, Spacers: Sized and shaped for strength and support of reinforcement during concrete placement conditions.
- C. Special Chairs, Bolsters, Bar Supports, Spacers Adjacent to Weather Exposed Concrete Surfaces: Plastic coated steel type; size and shape as required.

2.03 FABRICATION

- A. Fabricate concrete reinforcing in accordance with CRSI Manual of Standard Practice and ACI SP-66.
- B. Splice reinforcement on at locations indicated on drawings. Indicate location of splices on shop drawings.

PART 3. EXECUTION

3.01 PLACEMENT

- A. Place, support and secure reinforcement against displacement. Do not deviate from required position. Clean reinforcement of foreign particles or coatings.
- B. Accommodate placement of formed openings.
- C. Conform to ACI 318 code for concrete cover over reinforcement.

3.02 FIELD QUALITY CONTROL

- A. Contractor shall notify the Owner's Representative at least 24 hrs. in advance of concrete placement. Placement of reinforcing shall occur in such sequence that the Owner's Representative has sufficient time to inspect the correctness of the reinforcing within the placement area. The Owner's Representative retains the right to require necessary revisions be made before concrete is placed.

END OF SECTION 03200

DIVISION 3 - CONCRETE
Section 03300 - Cast-In-Place Concrete

PART 1. GENERAL

1.01 WORK INCLUDES

- A. The complete installation of cast-in-place concrete structures, including joint sealants.

1.02 RELATED SECTIONS

- A. Section 03100 - Concrete Formwork: Formwork and accessories.
- B. Section 03200 - Concrete Reinforcement.
- C. Section 03400 – Concrete Embedment Liner

1.03 REFERENCES

- A. ACI 301 – Structural Concrete for Buildings.
- B. ACI 302 - Guide for Concrete Floor and Slab Construction.
- C. ACI 304 - Recommended Practice for Measuring, Mixing, Transporting and Placing Concrete.
- D. ACI 305R - Hot Weather Concreting.
- E. ACI 306R - Cold Weather Concreting.
- F. ACI 308 - Standard Practice for Curing Concrete.
- G. ACI 318 - Building Code Requirements for Reinforced Concrete.
- H. ASTM C31 - Concrete Test Specimens.
- I. ASTM C33 - Concrete Aggregates.
- J. ASTM C94 - Ready-Mixed Concrete.
- K. ASTM C150 - Portland Cement.
- L. ASTM C260 - Air Entraining Admixtures for Concrete.

03300-1

M. ASTM C494 - Chemical Admixtures for Concrete.

1.04 SUBMITTALS

A. Product Data: Provide data on joint devices, attachment accessories, admixtures.

1.05 QUALITY ASSURANCE

A. Perform Work in accordance with ACI 301.

B. Acquire cement and aggregate from same source for all work.

C. Conform to ACI 305R when concreting during hot weather.

D. Conform to ACI 306R when concreting during cold weather.

1.06 COORDINATION

A. Coordinate this Section with other Sections which require embedment of components in cast-in-place concrete.

1.07 PRODUCT DATA

A. Submit proposed mix design to Owner's Representative for review prior to commencement of work. Identify source and provide material certificates for cement, fine and coarse aggregates. Provide recent laboratory gradation for fine and coarse aggregates and mix design information in accordance with ACI 301.

B. Submit Construction joint plan.

PART 2. PRODUCTS

2.01 CONCRETE MATERIALS

A. Cement: ASTM C150, Type I - Normal Portland Type, Gray Color.

B. Fine and Coarse Aggregates: ASTM C33.

C. Water: Potable.

2.02 ADMIXTURES

A. Air Entrainment: ASTM C260.

- B. Chemical: ASTM C494. Maximum 0.05% Chloride Ion Contents.
- C. The use of calcium chloride in any concrete is not permitted.

2.03 ACCESSORIES

- A. Non-Shrink Grout: Premixed compound consisting of non-metallic aggregate, cement, water reducing and plasticizing agents; capable of developing minimum compressive strength of 2,400 psi in 48 hours and 7,000 psi in 28 days.
- B. Curing Compound: Dress and Seal No. 18 by L&M Construction Chemicals, MB-429 by Master Builders, or Sikagard Cure/Hard by the Sika Corporation.
- C. Epoxy Grouted Adhesive Anchors: Hilti, Red Head, Simpson, or Rawl.

2.04 CONCRETE MIX

- A. Mix concrete in accordance with ACI 304. Deliver concrete in accordance with ASTM C94.
- B. Select proportions for normal weight concrete in accordance with ACI 301.
- C. Provide normal weight concrete of the following characteristics:
 - 1. Compressive strength at 28 days: 4,000 psi.
 - 2. Slump: 4 in. - A tolerance of up to 1 in. above the maximum shall be allowed for one batch in any five consecutive batches tested.
 - 3. Water/cement ratios: 0.4 (max).
- D. Use accelerating admixtures in cold weather only when approved by Owner's Representative. Use of admixtures will not relax cold weather placement requirements.
- E. Use set-retarding admixtures during hot weather only when approved by Owner's Representative.
- F. Water-reducing admixtures may be used in all concrete except footings and in strict compliance with the manufacturer's directions.
- G. Add air-entraining agent to concrete mix for air content of 6% (\pm 1%).

PART 3. EXECUTION

3.01 EXAMINATION

- A. Verify requirements for concrete cover over reinforcement.
- B. Verify that anchors, seats, plates, reinforcement and other items to be cast into concrete are accurately placed, positioned securely, and will not cause hardship in placing concrete.

3.02 PLACING CONCRETE

- A. Place concrete in accordance with ACI 301.
- B. Notify Owner's Representative minimum of 24 hours prior to commencement of operations.
- C. Ensure reinforcement, inserts, and embedded parts are not disturbed during concrete placement.
- D. Maintain records of concrete placement. Record date, location, quantity, air temperature, and test samples taken.
- E. Place concrete continuously between predetermined expansion, control, and construction joints.
- F. When air temperature is between 80°F and 90°F, reduce the mixing and delivery time specified in ASTM C94 from 1-1/2 hours to 75 minutes. When the air temperature is above 90°F, reduce the mixing and delivery time to 60 minutes.
- G. Cold weather concreting. Comply with ACI 306 except as follows:
 - 1. In freezing weather, provide suitable means for maintaining concrete temperature at a minimum of 70°F for three days, or 50°F for five days after placing.
 - 2. Cooling of concrete to outside temperature: Not faster than 1° per hour for first day and 2° per hour thereafter until outside temperature is reached.
 - 3. Maximum temperature of concrete produced with heated aggregated, heated water, or both, at any time during its production or transportation: 90°F.
 - 4. Do not mix chemicals or other foreign materials in concrete to prevent freezing or to accelerate hardening of concrete, unless approved in writing by Owner's Representative.

- H. Hot weather concreting. Comply with ACI 305R.
 - 1. ACI recommendations shall be observed when any combination of high air temperature, low relative humidity and wind velocity tend to impair the quality of fresh or hardened concrete.
 - 2. Retarding and water reducing admixtures shall be approved in writing for each concrete mix design prior to placement.

3.03 CONCRETE FINISHING

- A. Provide exterior concrete formed surfaces to be left exposed with smooth rubbed finish in accord with ACI 301. All other formed surfaces shall have fins, projections and offsets removed.
- B. Provide Class A tolerances to exterior concrete slabs according to ACI 301.
 - 1. Broom finish all exterior slabs. Broom out all tool marks.
- C. Pitch slabs to drain.

3.04 CURING AND PROTECTION

- A. Immediately after placement, protect concrete from premature drying, excessively hot or cold temperatures, and mechanical injury.
- B. Maintain concrete with minimal moisture loss at relatively constant temperature for a period necessary for hydration of cement and hardening of concrete in accordance with ACI 308.
- C. Cure and protect finished concrete slabs in accordance with ACI 308.

3.05 FIELD QUALITY CONTROL

- A. Field inspection and testing will be performed in accordance with ACI 301 and under provisions of Section 01010, paragraph 8.0.
- B. Testing firm will take cylinders, perform slump and air entrainment tests in accordance with ACI 301.
- C. Provide free access to Work and cooperate with appointed firm.
- D. Submit proposed concrete mix design to Owner's Representative firm for review 14 days prior to commencement of Work.

- E. Testing frequency shall be as specified in Section 01010, paragraph 8, except that one additional test cylinder will be taken during cold weather concreting, cured on job site under same conditions as concrete it represents.

3.06 PATCHING

- A. Defective Concrete: Concrete not conforming to required lines, details, dimensions, tolerances or specified requirements.
- B. Repair or replacement of defective concrete will be determined by Owner's Representative and performed by the Contractor at no additional cost to the project.
- C. Do not patch, fill, touch-up, repair, or replace exposed concrete except upon express direction of Owner's Representative for each individual area.

END OF SECTION 03300

DIVISION 3 - CONCRETE

Section 03400 - Concrete Embedment Liner

PART 1. GENERAL

1.01 WORK INCLUDES

- A. Specifications and guidelines for manufacturing and installing high-density polyethylene embedment liners.

1.02 RELATED SECTIONS

- A. Section 03100 - Concrete Formwork.
- B. Section 03300 - Cast-in-Place Concrete.

1.03 REFERENCES

A. American Society for Testing and Materials (ASTM)

1. D 1505 Test Method for Density of Plastics by the Density-Gradient Technique
2. D 1603 Test Method for Carbon Black in Olefin Plastics
3. D 5199 Standard Test Method for Measuring Nominal Thickness of Geotextiles and Geomembranes
4. D 5596 Standard Test Method for Microscopic Evaluation of the Dispersion of Carbon Black in Polyolefin Geosynthetics
5. D 6693 Standard Test Method for Determining Tensile Properties of Nonreinforced Polyethylene and Nonreinforced Flexible Polypropylene Geomembranes
6. D 1204 Standard Test Method for Linear Dimensional Changes of Nongrid Thermoplastic Sheeting or Film at Elevated Temperature
7. D 696 Standard Test Method for Coefficient of Linear Thermal Expansion of Plastics Between -30°C and 30°C With a Vitreous Silica Dilatometer
8. D 746 Standard Test Method for Brittleness Temperature of Plastics and Elastomers by Impact
9. D 570 Standard Test Method for Water Absorption of Plastics
10. E 96 Standard Test Method for Water Vapor Transmission of Material

1.04 SUBMITTALS

- A. All work for and in connection with the installation of the lining, field seaming and welding joints shall be completed in strict conformity with all applicable instructions and recommendations of the liner manufacturer.

03200-1

- B. Included with the shipment of liner, submit certified test reports that the liner and material are manufactured in accordance with standards specified herein.

1.05 QUALIFICATIONS

- A. The HDPE liner specified in this section shall be furnished by a manufacturer who is fully experienced, reputable and qualified in the manufacturing of the materials. The manufacturer must at least 10 years of manufacturing experience.
- B. Locking devices must be extruded to the sheet as a one step process.
- C. Liner shall be GSE StudLiner as manufactured by GSE Lining Technology, Inc.
- D. Liner shall be 8 feet in width.
- E. Liner shall demonstrate a minimum pull-out strength of 14,000 psf.

1.06 COORDINATION

- A. Coordinate with placement of formwork, formed openings and other work.

PART 2. PRODUCTS

2.01 ROLL DIMENSIONS

- A. Embedment sheets shall be produced in rolls that are 8.0 ft (2.4 m) in width and a thickness range of 80 mils (2.0 mm) to 200 mils (5.0 mm) in thickness. Roll lengths vary according to thickness.
- B. Locking studs of the same material as that of the liner shall be integrally extruded with the sheet. Stud spacing shall be on approximate 1.25 in (30 mm) centers, such that there are approximately 110 studs per square foot (1200 per square meter).

2.02 MATERIAL PROPERTIES

- A. The material used in the embedment liner and in all welding strips shall be made from 97-98% virgin high density polyethylene and 1.5-3% carbon black or pigmentation for the purpose of an otherwise specified color.
- B. Plasticizer shall not be added to the resin formulation.

- C. Embedment sheet and welding strips shall be free of holes, pinholes, bubbles, blisters, excessive contamination by foreign matter, and nicks and cuts on roll edges.
- D. The HDPE cap strips shall be made from HDPE, have good impact resistance and have an elongation sufficient to bridge up to 1/4 inch settling cracks.
- E. Cap strips shall be approximately 4 inches wide or greater and shall be equivalent to that of the liner.
- F. Material shall maintain a repairable state through it's lifecycle by methods approved and recommended by the manufacturer.
- G. Embedment sheets shall have the following physical properties when tested in accordance with Table 1.
- H. Raw resin shall have the following properties when tested in accordance with Table 2.

Table 1: Material Properties

Property	Test Method	Nominal Value				Testing Frequency
Thickness, mm (mil)	ASTM D 5199	2.00 (80)	3.00 (120)	4.00 (160)	5.00 (200)	Every 5 th roll
Density, g/cm ³	ASTM D 1505	0.94	0.94	0.94	0.94	1/100,000 ft ²
Tensile Properties	ASTM D 6693					
Strength@Yield, lb/in ² (MPa)	Type IV, Dumbbell	2,200 (14.5)	2,200 (14.5)	2,200 (14.5)	2,200 (14.5)	1/100,000 ft ²
Elongation @ Break, %	G.L.= 2.0in.	500	500	500	500	
Stud Pull-Out Strength ¹ , lb/ft ² (kN/m ²)		>14,000 (669.89)	>14,000 (669.89)	>14,000 (669.89)	>14,000 (669.89)	1/ product
Carbon Black Content/ Pigment Content, %						1/100,000 ft ²
Black Liner	ASTM D 1603, mod.	2-3	2-3	2-3	2-3	
Gray Liner	ASTM D 5630, mod.	1.5 – 2.5	1.5 – 2.5	1.5 – 2.5	1.5 – 2.5	
Carbon Black Dispersion ²	ASTM D 5596	Note 2	Note 2	Note 2	Note 2	1/100,000 ft ²
Notched Constant Tensile Load, hours	ASTM D 5397	400	400	400	400	1/ formulation
Coefficient of Linear Thermal Expansion, per °C	ASTM D 696	1.20E-04	1.20E-04	1.20E-04	1.20E-04	1/ product
Low Temperature Brittleness, °C	ASTM D 746	-77	-77	-77	-77	1/ product
Dimensional Stability, % (each direction)	ASTM D 1204	± 1.0	± 1.0	± 1.0	± 1.0	1/ product
Water Absorption, %	ASTM D 570	0.1	0.1	0.1	0.1	1/ product
Water Vapor Transmission, (g/m ² /day)	ASTM E 96	<0.01	<0.01	<0.01	<0.01	1/ product

03200-3

¹Note: Concrete must have a compressive strength of at least 5,000 lb/in² (34,500 kPa).

²Note: Dispersion only applies to near spherical agglomerates. 9 of 10 views shall be Category 1 or 2. No more than 1 view for category 3.

03200-4

Table 2: Raw Material Properties

Property	Test Method	Value	Testing Frequency
Density, g/cm ³	ASTM D 1505	0.932	1/ resin lot
Melt Flow, g/10 min	ASTM D 1238 (190/2.16)	≤ 1.0	1/ resin lot
OIT, minutes	ASTM D 3895 (1atm/200°C)	100	1/ formulation

2.03 MATERIAL SUPPLY

- A. Embedment sheets shall be supplied in roll form, sheets, pre-fabricated tubes or panels.
- B. Cap strips shall be supplied in 4 inch widths or greater.

PART 3. EXECUTION

3.01 PLACEMENT

- A. Place, support and secure reinforcement against displacement. Do not deviate from required position. Clean reinforcement of foreign particles or coatings.
- B. Accommodate placement of formed openings.
- C. Conform to ACI 318 code for concrete cover over reinforcement.

3.02 FIELD QUALITY CONTROL

- A. Contractor shall notify the Owner's Representative at least 24 hrs. in advance of concrete placement. Placement of the Concrete Embedment Liner shall occur in such sequence that the Owner's Representative has sufficient time to inspect the correctness of the placement within the concrete formwork area. The Owner's Representative retains the right to require necessary revisions be made before concrete is placed.

END OF SECTION 03200



Appendix E: Operation & Maintenance Manual for #1 Ash Pond



Coffeen Power Station

Operational Procedure

X-XXX-XXXX--XXX

Operation & Maintenance Manual for #1 Ash Pond
(Bottom Ash Recycle Pond)

Effective Date: xx/xx/xxxx

Reason for Change: New Procedure

Approved By: _____ x _____ Date: _____ xx/xx/xxxx

x
John Romang

Responsible Department: Coffeen Power Station, Technical Services Department

- This entire document shall be in the field during procedure performance.
 - The following portions of this procedure shall be in the field during procedure performance: _____
 - _____ from this procedure shall be in the field during procedure performance.
 - No part of this procedure is required to be in the field during procedure performance.
-

Table of Contents

<u>Section</u>	<u>Page Number</u>
1.0 Purpose	1
2.0 Scope	1
3.0 Responsibilities.....	1
4.0 Historical Information	1
5.0 Water Supply	Error! Bookmark not defined.
6.0 Operations Requirements	2
7.0 Dam Safety Requirements.....	3
8.0 Maintenance Logs.....	4
9.0 Contact Numbers.....	4
10.0 References.....	4

- 1.0 Purpose
 - 1.1 This procedure is intended to ensure the safe and environmentally responsible operation and use of the #1 Ash Pond (Bottom Ash Recycle Pond) at the Coffeen Power Station. The primary purpose of the #1 Ash Pond is for the removal of bottom ash by settling and the recirculation of slag tank water. The pond is used to supply water to the Unit 1 and Unit 2 ash handling systems via the recycle pumps.
- 2.0 Scope
 - 2.1 This procedure applies to all onsite personnel and the Dam Safety Group staff.
- 3.0 Responsibilities
 - 3.1 Outside Unit Operator – Checks the pond level and screens once a shift. Operates the facilities as described in this Operational Procedure. Reports any conditions noted during routine activities to the Shift Supervisor and Chemistry Department. Writes job requests if a problem is identified.
 - 3.2 Shift Supervisor (SS) - Calls the Chemistry Department when structural concerns or overflow conditions are reported. Make entries into the shift electronic log book (e-log) indicating the concern and actions taken.
 - 3.3 Dam Safety Inspector - Conducts weekly detailed dam safety inspections and provides a report with findings and recommendations. Make entries in e-log indicating the concern and actions taken.
- 4.0 Historical Information
 - 4.1 The #1 Ash Pond was initially constructed to be a mixed ash deposition pond and was put in service in the mid-1960's. It is located east of the Main Building. It is a 23 acre pond with a maximum outer berm height of 41.5 feet above ground surface level (approximately elevation 637.5'). The pond overflow was located on the north east corner of the pond and discharged into the flume.
 - 4.2 The #1 Ash Pond was converted to act as a closed loop system in the late 1970's when the dewatering bins were installed. The mixed ash was removed and deposited into the #2 ash pond during the closure of #2 pond. The #1 Ash Pond berms were modified and an inner berms was added to the pond to aid in dropping out bottom ash solids. Exterior berm elevation is approximately 637.5 feet.

- 4.3 The #1 Ash Pond was equipped with an emergency overflow at the outlet structure. When the pond level reaches approximately 6.5 feet from the top of the berm, it will overflow into the flume. Overflow will be reported to the EPA. In 2011 there was an assessment of the overflow pipe which showed no obstructions or damage.
- 4.4 In 2006, the bottom ash system was modified to directly sluice bottom ash into the pond, bypassing the retired dewatering bins. Bottom Ash is removed from the pond via an outside contractor on an as needed (typically daily) basis.

5.0 Water Supply

All water inlets to the pond are located on the west side of the pond.

The ash sluice lines (from the valve house) discharge to the pond. These lines are used to convey ash from the slag handling system to the #1 Ash Pond. These lines are the southern most of the pond inlets. HPSW system is routed to the pond (valve house sparger valves, floor drains at Unit 1 cyclone level).

The Slag Tank Overflow sump pumps discharge into the pond at the concrete culvert located directly east of the lime/soda ash silo. Also in this area, a small stainless line extends thru the concrete. This is the discharge of the sludge pumps at the Waste Treatment System in the Recycle Pump House building.

The recycle pump flow control valves discharge to the pond through a line located at the northwest corner of the pond. Also in the vicinity of this line is the discharge pipe of the recycle pump house sump pumps.

Water from the Unit 1 and Unit 2 oil water separators are typically routed to the pond via the Slag Tank Overflow Pump (STOP) House sumps. Water entering these sumps are floor and roof drains in the plant and the yard area immediately to the north of the main building.

6.0 Operations Requirements

Pond Level - Plant personnel shall monitor the level of the #1 Ash Pond on a daily basis. Pond level is maintained at approximately 1.0' to 1.5' at the water level staff gauge located on the pond side of the screens. The staff gauge has elevation 629.0' as the 0 elevation.

At 2.0' water level (elevation 631.0 feet), the pond overflows resulting in a sampling and analysis requirement for Total Suspended Solids and Oil and Grease with reporting of the results to the IEPA. If the pond is found at or above 2.0' on the pump side staff gauge, contact Chemistry immediately.

Water can be added to the pond from either the Unit 1 or Unit 2 Low Pressure Service Water (LPSW) headers via piping that discharges to the slag tank overflow trench.

Water can be drained from the pond via the water supply pipe to the dewatering bins. Opening this valve drains water from the recycle header which will remove water from the #1 Ash Pond.

Recycle Pump Intake Structure – Suction to the recycle pumps is supplied from the intake structure located at the west end of the north leg of the pond. This is the only water discharge point from the pond. Water level staff gauges are located upstream and downstream of the trash screens for determination of the screen differential. At 0.5' differential, the screens should be cleaned. Level sensors are also installed upstream and downstream of the screens. Digital displays of the upstream and downstream levels are located along the north side of the catwalk leading out to the screen enclosure. These level sensors will generate a high screen differential alarm in the Control Room DCS. Check screen differential (should clean screens at 6 inches differential.) When the screens become plugged, suction to the recycle pumps is reduced. Call shift supervisor to report if screens needs to be cleaned.

Oil Boom – Plant personnel shall monitor the oil boom that is provided upstream of the intake structure. Check condition of oil booms across pond, at discharge, and across pond inlet. Booms should be replaced when they become oil saturated or damaged. Also check that booms have not come unattached from one another. Write JR to change out booms or to reconnect booms when required.

Emergency Conditions – If a condition arises where there is a possibility of an embankment failure, then the following procedures will be followed:

1. Notify the Supervising Engineer Dam Safety immediately.

7.0 Dam Safety Requirements

- ### 7.1 Dam Safety Inspections - The plant's impoundment and flood prevention structures shall be inspected and maintained in a manner to ensure safe and environmentally responsible operations. A regular maintenance program shall be performed and shall consist of the following inspection items:

1. Earth embankments: Walk the crest, side slopes, and downstream toe of the dam concentrating on surface erosion, seepage, cracks, settlement, slumps, slides, and animal burrows. Frequency of inspection: Weekly.
2. Vegetation: Grass should be a thick vigorous growth to stabilize the earth embankment soils and prevent erosion from occurring. There should be NO trees on the earth embankment and none within a minimum of 20 feet of the embankment toe or other structures. Mowing frequency: Semiannually.
3. Well Readings: Record level of wells on the crest and toe of the berm. Frequency: Quarterly.
4. Special Inspections – Special inspections of the levees and ash pond berms shall be performed after earthquakes, floods, water level exceedance in the ponds, or heavy rainfall events. Inspection and report shall be equal to an annual inspection level of detail. Water level in the pond should be noted after a heavy rainfall. Dam Safety staff shall accompany plant personnel on special inspections. Frequency: As required.

8.0 Maintenance Log

- 8.1 Dam & Berm Inspector shall enter on e-log under the Dam Safety tab all weekly inspections, any usual occurrences, and maintenance performed.

9.0 Contact Numbers

Plant Environmental Supervisor: John Romang / 217-534-7629

Plant Dam & Berm Inspector: Vito Passariello / 217-534-7664

Plant Control Room: 217-534-7668 / 217-534-7669

Supervising Engineer Dam Safety: Steve Bluemner / 314-554-6298

Dam Safety Staff Contact: Mike Wagstaff / 314-554-6296

10.0 References



Appendix F: Operation and Maintenance Manual, Gypsum Management Facility Operation (2015)

Operation and Maintenance Manual
Coffeen Energy Center
Gypsum Management Facility
Montgomery County, Illinois

IDNR Permit # DS2014019
Dam Permit # IL50578 & IL50579

Prepared For:

ILLINOIS POWER GENERATING COMPANY
Coffeen Energy Center
134 CIPS Lane
Coffeen, Illinois 62017

Prepared By:

HANSON PROFESSIONAL SERVICES INC.
1525 South Sixth Street
Springfield, Illinois 62703

Amended By:

DYNEGY OPERATING COMPANY
1500 Eastport Plaza Drive
Collinsville, Illinois 62234

Original: February 2008
Amended: March 2015

**OPERATION AND MAINTENANCE MANUAL
COFFEEN ENERGY CENTER
GYPSUM MANAGEMENT FACILITY
MONTGOMERY COUNTY, ILLINOIS**

TABLE OF CONTENTS

<u>Section</u>	<u>Page</u>
SECTION 1.0 General	1
1.1 Reasons For Development And Dissemination Of The O&M Manual	1
1.2 General Responsibilities Concerning Dams	1
SECTION 2.0 Definitions	2
SECTION 3.0 Information About The Dams	4
3.1 Location	4
3.2 Description Of Dam And Appurtenances.....	4
3.3 Size and Hazard Classification	5
3.4 Purpose Of The Dams	5
3.5 Pertinent Data.....	6
SECTION 4.0 Operations Activities.....	8
4.1 Introduction.....	8
4.2 Site Operations and Personnel	8
4.2.1 Site Operations	8
4.2.2 Personnel	8
4.3 Gypsum Management Facility Startup.....	8
4.4 Water Balance	9
4.5 Gypsum Management Facility Operation.....	9
4.5.1 Routine Operations	9
4.5.2 Piezometer Installation and Monitoring.....	10
4.6 Dam Inspections.....	12
4.6.1 Operation and Maintenance Inspection.....	12
4.6.2 Engineering Inspection	15
4.6.3 Review of Emergency Action Plan.....	16
SECTION 5.0 Maintenance Activities.....	17

LIST OF TABLES

Table 3-1 Pertinent Data for the Gypsum Stack Earthen Dam.....	6
Table 3-2 Pertinent Data for the Recycle Pond Dam.....	7

LIST OF FIGURES

Figure 4-1 Anticipated Phreatic Surface in Gypsum Stack.....	11
--	----

LIST OF APPENDICES

APPENDIX A –	Location Map
APPENDIX B –	Operation and Maintenance Inspection Checklist
APPENDIX C –	Engineering Inspection Form
APPENDIX D –	Herbicides
APPENDIX E –	Construction Drawings

SECTION 1.0 **GENERAL**

This operation and maintenance (O&M) manual outlines objectives, proposed policies, responsibilities, and procedures for Coffeen Energy Center personnel who are responsible for the management of the Coffeen Energy Center Gypsum Management Facility (GMF). The GMF incorporates two reservoirs, the Gypsum Pond and the Recycle Pond, for processing and storing gypsum.

1.1 REASONS FOR DEVELOPMENT AND DISSEMINATION OF THE O&M MANUAL

The State of Illinois Rivers, Lakes and Streams Act, (615 ILCS 5) Paragraph 23a includes the statement "The Department is authorized to carry out inspections of any dam within the State, and to establish standards and issue permits for the safe construction of new dams and the reconstruction, repair, operation and maintenance of all existing dams." (emphasis added).

Part 3702 of Section 17 of the Illinois Administrative Code, Chapter I entitled the "Construction and Maintenance of Dams" details the requirements to obtain a permit for the construction, operation, and maintenance of a dam. Section 3702.40 b) includes the following statements:

"4) An applicant for a Class I or II dam shall submit an operational plan specifying the method and schedule for the operation of the dam and the routine operating procedures to keep the dam in good working order, including an emergency warning plan." and

"5) As a condition of each permit, the dam owner shall submit a maintenance plan detailing the procedures and schedules to be followed to maintain the dam and its appurtenances in a reasonable state of repair."

Thus, it is a requirement of all dam owners who have dams which fall under the jurisdiction of the Illinois Department of Natural Resources Office of Water Resources (IDNR-OWR) to operate and maintain them safely.

As a dam owner, Illinois Power Generating Company (IPGC) Coffeen Energy Center is responsible for the safety of the public and for maintaining the structures at the facility for both safety and economy. The overall public interest is served by providing a document to serve as a basis for the safe and economical operation and maintenance of the dam during both emergency and day-to-day conditions.

1.2 GENERAL RESPONSIBILITIES CONCERNING DAMS

IPGC is responsible for the operation and maintenance of the Gypsum Pond Dam and the Recycle Pond Dam. These responsibilities include general maintenance (mowing, removing debris from decants, placing riprap where needed, etc.), operation, inspection and emergency action decisions.

SECTION 2.0 **DEFINITIONS**

Appurtenant Works - The structures or machinery auxiliary to dams which are built to operate and maintain dams; such as outlet works, spillways, gates, valves, channels, etc.

Boil - A stream of water discharging from the ground surface downstream of the dam carrying with it a volume of soil which is distributed around the hole formed by the discharging water.

Berm - A horizontal step or bench in the sloping profile of an embankment dam.

Breach - A break, gap, or opening (failure) in a dam which releases impoundment water.

Dam - A barrier built for impounding or diverting the flow of water.

Dike (Levee) - An embankment, usually applied to embankments or structures built to protect land from flooding.

Drain, Layer or Blanket - A layer of pervious material in a dam to facilitate the drainage of the embankment including such items as a toe drain, a weephole, and a chimney drain.

Drawdown - The resultant lowering of the water surface level due to the release of water from the impoundment.

Embankment - Fill material, usually rock or earth, placed with sloping sides.

Earthen Dam - Any dam constructed of excavated natural materials.

Emergency Action Plan - A predetermined plan of action to be taken to reduce the potential for property damage and loss of lives.

Failure - An incident resulting in the uncontrolled release of water from the dam.

Freeboard - The vertical distance between a stated water level and the top of the dam.

Gate or Valve - In general, a device in which a leaf or member is moved across the waterway to control or stop the flow.

Groin - The junction of the upstream or downstream face of the dam with the valley wall.

Maintenance - The upkeep, involving labor and materials, necessary for efficient operation of dams and their appurtenant works.

Operation - The administration, management, and performance needed to operate the dam and appurtenant works.

Operation and Maintenance Inspection - Inspections conducted by the dam operator. These inspections are frequent visual "Walk-around" inspections of the dam surface and appurtenant works.

Outlet - An opening through which water can freely discharge for a particular purpose from an impoundment.

Phreatic Surface - The upper surface of saturation in an embankment.

Piping - The progressive development of internal erosion by seepage, appearing downstream as a hole or seam, discharging water that contains soil particles.

Riprap - A layer of large stones, broken rock or precast blocks placed in a random fashion usually on the upstream slope of an embankment dam, on a reservoir shore, or on the sides of a channel as a protection against wave and ice action.

Silt/Sediment - Soil particles and debris in an impoundment.

Slump/Slide Area - A portion of earth embankment which moves downslope, sometimes suddenly, often with cracks developing.

Spillway System - A structure or structures over or through which flows are discharged. If the flow is controlled by gates, it is considered a controlled spillway. If the elevation of the spillway crest is the only control of the flows, it is considered an uncontrolled spillway.

Emergency Spillway - A spillway designed to operate very infrequently, only during exceptionally large floods, usually constructed of materials expected to erode slowly.

Principal Spillway - The main spillway which controls both normal and flood flows and is usually constructed of non-erodable materials.

Auxiliary Spillway - A spillway which works in conjunction with the principal spillway to control flood flows and is usually constructed of non-erodable materials.

Stilling Basin - A basin constructed to dissipate the energy of fast flowing water, such as from a spillway, and to protect the streambed from erosion.

Toe of Embankment - The junction of the face of the dam with the ground surface in the floodplain upstream or downstream of the dam.

SECTION 3.0
INFORMATION ABOUT THE DAMS

3.1 LOCATION

The Gypsum Pond Dam and Recycle Pond Dam are located in the NW 1/4 of Section 11, Township 7 North, Range 3 West of the Third Principal Meridian in Montgomery County, Illinois. More specifically, the dams are located approximately 1.5 miles south of Coffeen, Illinois. A map showing the location of the dams is included in Appendix A.

3.2 DESCRIPTION OF DAM AND APPURTENANCES

The gypsum pond perimeter earthen dam, the gypsum pond “gypsum” dam, and the recycle pond dam will all be regulated in accordance with 17 Illinois Administrative Code (IAC) Part 3702, Construction and Maintenance of Dams. The gypsum pond perimeter earthen dam, which will be lined with a dual high density polyethylene (HDPE) geomembrane system, will have a maximum embankment height of 13 ft and a maximum impounding capacity of 442 acre-ft (measured at the top of earthen dam elevation 632 ft). There will be an additional 123 acre-ft of incised storage. The total volume of gypsum stored within the completed gypsum pond dams will be approximately 2,478 acre-ft.

The dam for the recycle pond, which will be lined with a 60 mil HDPE geomembrane, will have a maximum embankment height of 16 ft and a maximum impounding capacity of 243 acre-ft (measured at the top of dam elevation 629 ft). There will be an additional 99 acre-ft of incised storage.

The gypsum pond will be divided into two sub-cells for the containment of scrubber sludge (gypsum). Discharges to the site will switch back and forth between the two sub-cells so that one sub-cell can be dewatered and raised while the other is in use. There will be two fixed decant pipes constructed in the gypsum stack – one for each sub-cell - which will discharge to stilling wells located adjacent to the perimeter ditches. The control elevation on the decant pipes will be maintained 5.0 ft below the lowest point on the stack cell crest. The decant pipes will enable the cells to be dewatered after storm events so that a minimum of 5.0 ft of freeboard will be maintained in each cell. A minimum of 4.7 ft of freeboard is required above the decant inlet to contain the Probable Maximum Flood (PMF) storm event in addition to peak wind generated waves.

The gypsum pond dam perimeter ditches will be located on the interior sides of the earthen dam. Runoff from the stack will be conveyed through the ditches to a transfer channel which will discharge into the recycle pond. The ditches will be trapezoidal in shape with a 15 ft bottom width, a maximum depth of 9 ft and a longitudinal slope of 0.0005 ft/ft. Side slopes will be 3H:1V. During operation, the ditches will be monitored for erosion. If erosion of the designed ditch geometry occurs, a geogrid will be used for stabilization.

The transfer channel between the gypsum pond dam and the recycle pond have a trapezoidal cross-section with 3H:1V side slopes will be lined with HDPE. The 500 ft long transfer channel will transition from a 32-ft bottom width at an invert elevation of 623.0 ft at the upstream end to a 60-ft bottom width at an invert elevation of 622.0 ft at the downstream end. The transfer channel will be fitted with stop logs capable of raising the discharge control elevation to 625.0 ft. To prevent degradation of the HDPE liner due to flow velocities, the transfer channel and a portion of the recycle pond dam will incorporate an additional sacrificial layer of HDPE.

The emergency spillway for the recycle pond will consist of three 6 ft by 6 ft precast reinforced concrete risers (drop inlets) with a top elevation of 624 ft (5 ft below the top of the dam). The recycle pond's HDPE liner will attach to the exterior sides of each riser. A 4-ft diameter HDPE outlet conduit will be constructed at each riser with an upstream invert of 615.0 ft and a downstream invert of 613.0 ft. Assuming a normal pool elevation of 624 ft (control elevation of the risers), the emergency spillway has been designed to pass the 24-hour PMF storm event with adequate freeboard to prevent overtopping of the recycle pond crest by wind generated waves. The emergency spillway has been provided in the event of accident or catastrophic rainfall only. It is not expected to be activated during the life of the facility. As designed, all discharges from the system will be through the pump house located on the southeast corner of the recycle pond.

3.3 SIZE AND HAZARD CLASSIFICATION

If a worst case failure of the gypsum pond dam were to occur, and the entire volume of the stack is released easterly into Coffeen Lake, the Coffeen Lake reservoir has adequate freeboard to accept this additional volume without overtopping the dam during flood events up to and including the 60 percent PMF. However, the power plant and several residences could potentially be impacted if the gypsum stack dam were to fail in a westerly direction. Considering the regulatory criteria established in Part 3702, the gypsum stack perimeter earthen dam and the gypsum stack "gypsum" dam are classified as intermediate-size Class I (high hazard potential) dams.

A failure of the recycle pond dam would discharge water to Coffeen Lake but it is not anticipated to result in loss of life or any significant economic damage. Breach analyses indicate that a failure of the recycle pond dam during a PMF event would be expected to result in an increase in the Coffeen Lake water surface elevation of not more than ½ inch. Accordingly, the recycle pond dam is classified as a small-size Class III (low hazard potential) dam.

3.4 PURPOSE OF THE DAMS

The dams will be used to dewater, store and dispose of flue gas desulphurization sludge (gypsum) from the Coffeen Power Station (the Plant). Gypsum will be transported to the Gypsum Pond Dam in slurry form (approximately 20 percent solids) and allowed to settle. Clarified process water will then be decanted to the recycle pond and returned to the Plant for reuse via a pipeline.

3.5 PERTINENT DATA

Pertinent data about the dams, appurtenant works, and reservoirs are presented in Table 3-1 and Table 3-2.

Table 3-1 Pertinent Data for the Gypsum Pond Earthen Dam
(Based on the Construction of 2 Gypsum Cells)

Perimeter Ditches			Transfer Channel		
Bottom Width	15.00	feet	Bottom Width	32.00	feet
Top Width	73.50	feet	Top Width	86.00	feet
Depth	9.00	feet	Depth	9.00	feet
Outer Side Slope	3:1	H:V	Upstream Invert	623.00	feet
Inner Side Slope	3:1	H:V	Downstream Invert	622.00	feet
Upstream Invert	624.85	feet	Weir Elevation	625.00	feet
Downstream Invert	623.00	feet	Weir Length (at 2 ft height)	44.00	feet
Ditch slope	0.00050	ft/ft			
Bank Full Cross-sectional Area	378.00	sf	Dam		
Length of Each Ditch (Centerline)	3710.00	feet	Top of Dam Elevation	632	feet
Bank Full Volume of Each Ditch	32.19	acre-ft	Reservoir Surface Area	77.29	acres
Total Ditch length (Centerline)	7420.00	feet	Total Watershed Area	77.29	acres
Total Ditch Bank Full Volume	64.39	acre-ft	Dam Length	7720	feet
			Dam Height	13	feet
1.0 PMF Storm Event			0.5 PMF Storm Event		
Storm Duration	24	hours	Storm Duration	24	hours
Peak Outflow Discharge	1100.7	cfs	Peak Outflow Discharge	541.1	cfs
Total Discharge Volume	228.83	acre-ft	Total Discharge Volume	122.41	acre-ft
Peak WSEL in Perimeter Ditches	629.89	feet	Peak WSEL in Perimeter Ditches	628.23	feet
Freeboard over Max WSEL	2.11	feet	Freeboard over Max WSEL	3.77	feet
Wave Runup/Wind Setup	2.06	feet	Wave Runup/Wind Setup	2.06	feet
Adequate Freeboard?	YES		Adequate Freeboard?	YES	
100-yr Storm Event - Critical Duration			100-yr Storm Event - 24 Hour Duration		
Storm Duration	12	hours	Storm Duration	24	hours
Peak Outflow Discharge	92.6	cfs	Peak Outflow Discharge	62.9	cfs
Total Discharge Volume	50.91	acre-ft	Total Discharge Volume	57.01	acre-ft
Peak WSEL in Perimeter Ditches	626.07	feet	Peak WSEL in Perimeter Ditches	625.84	feet
Freeboard over Max WSEL	5.93	feet	Freeboard over Max WSEL	6.16	feet
Wave Runup/Wind Setup	2.06	feet	Wave Runup/Wind Setup	2.06	feet
Adequate Freeboard?	YES		Adequate Freeboard?	YES	

Note: The Critical Storm Duration is the duration of the rainfall event which produces the highest reservoir water surface elevation in the Gypsum Stack Perimeter Ditches for the given storm frequency. In each case, the starting normal pool elevation of the Recycle Pond is considered to be at elevation 624 ft.

Table 3-2 Pertinent Data for the Recycle Pond Dam
(Based on the Construction of 2 Gypsum Cells)

Dam			3 Spillways- 6ft x 6ft inlet w/ 4ft dia outlet pipe		
Top of Dam Elevation	629	feet	Weir Length	22	feet
Invert of Reservoir Elevation	605	feet	Weir Elevation	624.00	feet
Reservoir Area at Invert	11.55	acres	Outlet Conduit Length	120	feet
Reservoir Area at Top of Dam	17.07	acres	Outlet Conduit Diameter (Inside)	48	inch
Total Reservoir Volume	341.91	acre-ft	Upstream Invert	615	feet
Volume at Elevation 624 ft	259.60	acre-ft	Downstream Invert	614	feet
Total Watershed Area	94.36	acres	Outlet Conduit Slope	0.00833	
Dam Length	3600	feet			
Dam Height	16	feet			
1.0 PMF Storm Event - Normal Pool at Elev. 624 ft			1.0 PMF Storm Event - Normal Pool at Elev. 609 ft		
Storm Duration	24	hours	Critical Storm Duration	24	hours
Peak Inflow	1261.6	cfs	Peak Inflow	1261.6	cfs
Peak Outflow	586.9	cfs	Peak Outflow	289.7	cfs
Peak Storage	315.47	acre-ft	Peak Storage	280.65	acre-ft
Peak WSEL (HEC-HMS)	627.45	feet	Peak WSEL (HEC-HMS)	625.34	feet
Freeboard over Peak WSEL	1.55	feet	Freeboard over Peak WSEL	3.66	feet
Wave Runup/Wind Setup	1.20	feet	Wave Runup/Wind Setup	1.20	feet
Adequate Freeboard?	YES		Water Released from Dam?	YES	
0.5 PMF Storm Event - Normal Pool at Elev. 624 ft			0.5 PMF Storm Event - Normal Pool at Elev. 613 ft		
Storm Duration	24	hours	Critical Storm Duration	24	hours
Peak Inflow	608.4	cfs	Peak Inflow	608.4	cfs
Peak Outflow	413.6	cfs	Peak Outflow	0	cfs
Peak Storage	286.48	acre-ft	Peak Storage	255.83	acre-ft
Peak WSEL (HEC-HMS)	625.69	feet	Peak WSEL (HEC-HMS)	623.75	feet
Freeboard over Peak WSEL	3.31	feet	Freeboard over Peak WSEL	5.25	feet
Wave Runup/Wind Setup	1.20	feet	Wave Runup/Wind Setup	1.20	feet
Adequate Freeboard?	YES		Water Released from Dam?	NO	
100-yr Storm Event - Normal Pool at Elev. 624 ft			100-yr Storm Event - Normal Pool at Elev. 619 ft		
Critical Storm Duration	12	hours	Critical Storm Duration	24	hours
Peak Inflow	113.2	cfs	Peak Inflow	76.6	cfs
Peak Outflow	95.8	cfs	Peak Outflow	0	cfs
Peak Storage	269.36	acre-ft	Peak Storage	258.48	acre-ft
Peak WSEL (HEC-HMS)	624.63	feet	Peak WSEL (HEC-HMS)	623.94	feet
Freeboard over Peak WSEL	4.37	feet	Freeboard over Peak WSEL	5.06	feet
Wave Runup/Wind Setup	1.20	feet	Wave Runup/Wind Setup	1.20	feet
Adequate Freeboard?	YES		Water Released from Dam?	NO	

Note: The above variation in normal pool elevations for the Recycle Pond is for the purpose of documenting the water surface elevation which must be maintained in the recycle pond in order to prevent the release of water from the GMF for the above described storm events.

SECTION 4.0 **OPERATIONS ACTIVITIES**

4.1 INTRODUCTION

The operations plan describes the proposed operation of the Coffeen Gypsum Management Facility (GMF) which includes the gypsum pond and the recycle pond.

4.2 SITE OPERATIONS AND PERSONNEL

4.2.1 Site Operations

The GMF will receive gypsum slurry 24 hours per day, seven days per week. Routine facility maintenance and construction activities will generally be conducted during day shift hours. The crest widths for both the gypsum stack earthen dam and the recycle pond dam are 20 ft. In addition, multi-directional ramps are being provided for both structures so that they are readily accessible by inspection, maintenance and gypsum recovery equipment.

The Plant is a restricted access location. Additional fencing around the perimeter of the active sedimentation cells of the gypsum stack and the recycle pond will be erected to prevent unauthorized access to the GMF, which is also under surveillance by security personnel.

4.2.2 Personnel

The proposed GMF will be owned and operated by Ameren Energy Generating Company (Ameren). Corporate offices are located in St. Louis, Missouri. Overall responsibility for the GMF operation lies with Ameren management personnel.

4.3 GYPSUM MANAGEMENT FACILITY STARTUP

The major components of the proposed GMF consist of:

- The gypsum stack dam/impoundment;
- The recycle pond;
- The earthen transfer channel that connects the two structures and through which process water will be decanted from the gypsum stack into the recycle pond; and
- The recycle pond decant and pumphouse through which process water will be returned to the Plant for reuse.

Both the recycle pond and the gypsum stack dam will be constructed before gypsum is placed within the gypsum stack dam/impoundment.

Upon startup, it is likely that the gypsum stack impoundment will have no more than a few feet of water in the bottom to prevent the high density polyethylene (HDPE) geomembrane from moving. The gypsum slurry (approximately 20 percent solids) will be pumped from the

Plant to the gypsum stack via piping. The piping will be HDPE with a suitable pressure rating for the intended hydraulic and static head. The HDPE pipe will discharge the slurry into the impoundment, and gypsum will settle by gravity.

It will take approximately 10 months before the gypsum stack impoundment is filled to elevation 623 ft, the point where process water may begin flowing into the recycle pond via the HDPE-lined earthen channel connecting the two structures. As soon as water begins to fill the recycle pond, it will be pumped back to the Plant for reuse.

4.4 WATER BALANCE

The capacity of the recycle pond has been designed to accommodate all precipitation runoff from the entire gypsum pond/recycle pond area during a 2-week complete maintenance outage at the Coffeen Power Station (the Plant) followed by a 12-week outage of one of the two units. The runoff and excess water accumulated during this time can be stored within the recycle pond without discharging. The design is based on the maximum 3.5 month precipitation that has occurred in the area since 1950. This occurred in April, May, June and half of July, 1957 and consisted of 28.83 inches of rainfall.

The water balance has been carried out for the expected life of the Site. During the first nine or ten months of operation, the water balance is positive, meaning that there is more water entering the gypsum stack/recycle pond system through process water and precipitation than is leaving the system through process water return and evaporation. However, there is 15 ft of freeboard between the pump discharge and the emergency spillway. With proper water-level management, the water surface will remain well below discharge elevation. After this initial startup period, the water balance is negative, meaning that other water sources will need to be continually added to the process water makeup stream to maintain the volume necessary for transport of the gypsum slurry.

The water balance is of particular concern since the entire system is designed to be a closed loop with no discharges. (*As previously noted, the recycle pond has been designed with an emergency spillway, but this is only to protect the structures in the event of an unforeseen accident or catastrophic rainfall event.*) Table 3.5-2 lists the maximum water surface elevation allowed in the recycle pond in order to prevent the discharge of water for the 100-year storm event and the 0.5 PMF storm event.

4.5 GYPSUM MANAGEMENT FACILITY OPERATION

4.5.1 Routine Operations

Gypsum slurry will initially be discharged at the southwestern corner of the gypsum pond impoundment. Settled gypsum will gradually create a plane of material sloping gently towards the north end of the impoundment. Depending on the slope of the settled gypsum, the discharge pipe may be moved to other corners of the impoundment to evenly distribute the material. Care must be taken during the initial filling period so to ensure that the sand layer covering the ring drains is not disturbed. If necessary, the sand may be armored with larger washed aggregate or

the impoundment may be gradually filled with water to cover the sand prior to the discharge of gypsum slurry into the impoundment.

Once the gypsum plane reaches approximately elevation 627 ft (5 ft below the earthen dam crest), a track excavator or similar piece of equipment will be used to create the first gypsum berm and to form the perimeter ditch. Each gypsum berm will be approximately 10 ft in height and will effectively create a two-compartment impoundment within its perimeter. Gypsum for construction of the gypsum berm will be obtained from the settled material on the inside of the berm, creating an inner ditch. Gypsum slurry will then be discharged alternately into the inner ditch of each compartment. Gypsum will settle out into the inner ditch and clarified process water will flood the compartment to a depth of several feet. This water will be decanted to the perimeter ditch by way of an HDPE decant pipe which will discharge to a stilling well located at the toe of the gypsum stack.

As each compartment fills with settled gypsum, the discharge piping will be moved to the alternate compartment. The compartment, or sub-cell, that is not in service will be allowed to dewater and another gypsum berm will be constructed on top of the previous gypsum berm, effectively raising the gypsum stack another 10 ft. This alternating cycle of gypsum discharge, compartment dewatering and berm construction will continue. Gypsum will be deposited in the stack with an average dry density of approximately 74 lb/ft³. Drawing No. C-10201-25 provides a visual description of this process.

4.5.2 Piezometer Installation and Monitoring

The side slopes of the gypsum pond will be constructed with 3:1 side slopes. After consolidation of the settled gypsum over time, the final slopes should approach 3.75:1. The stability of each gypsum pond slope is critically dependent on the location of the phreatic surface which is anticipated to develop within the stack. Ring drains are intended to lower the phreatic surface so that it is located an adequate distance from the surface of the slope in order to maintain slope stability. In order to monitor the phreatic surface within the stack, piezometers will be installed on each side of the gypsum pond. The piezometers will be installed every 15 vertical feet up the slope (45 horizontal feet based on 3:1 side slopes) and will extend to a depth of at least 15 feet below the anticipated phreatic water surface elevation as shown in Figure 4-1. At the time of installation, each piezometer will be labeled with the “critical elevation” corresponding to the anticipated phreatic surface elevation at that location. The anticipated phreatic surface elevation is the water surface elevation which was used in the slope stability analysis of the gypsum pond. The water level in each piezometer will be read and recorded on a monthly basis. If at any time a reading is recorded higher than “critical elevation” for that specific peizometer, the design engineer must be contacted immediately for evaluation of the reading. Any readings above the “critical elevation” may be indicative of improper ring drain function and/or slope instability which could lead to a failure of the gypsum stack. Therefore, it is critical that the piezometers are installed in accordance with the construction plans and specifications and monitored in accordance with this manual. It may be necessary to install additional subdrainage to maintain the phreatic surface at the desired level within the gypsum stack.

Figure 4-1 Anticipated Phreatic Surface in Gypsum Pond

Refer to figure at the end of the report text.

4.6 DAM INSPECTIONS

The inspection program includes two types of dam inspections. The first is regularly conducted by the dam operator and is referred to as an Operation and Maintenance Inspection. The second type of inspection, referred to as the Engineering Inspection, is conducted by a qualified engineer approved by IPGC. All engineering inspection reports must be signed and sealed by an Illinois Registered Professional Engineer.

The dam operator will perform monthly Operation and Maintenance Inspections of the gypsum pond perimeter earthen dam and the gypsum berms and side slopes during the operating life of the structure. During these inspections, the gypsum stack ditches and the transfer channel will also be examined for signs of erosion and liner degradation. The “operating life of the structure” will be considered to cease upon covering of the gypsum with an HDPE/soil cover. Engineering Inspections will be conducted on an annual basis during the operating life of the structure and will continue after covering of the gypsum pond until authorization to abandon the structure is received from IDNR/OWR.

4.6.1 Operation and Maintenance Inspection

Occasional "walk-around" inspections of the dams and appurtenant works are to be made by the dam operator. During these inspections, a checklist of items to be maintained and items to be observed should be recorded. Appendix A provides an example of the Operation and Maintenance Inspection Checklist to be utilized for these inspections. **If any of the following items are found to be unusual or are cause for concern, the Shift Supervisor should be notified and the Emergency Action Plan should be immediately consulted for guidance on an appropriate course of action.**

Frequency: Operation and maintenance inspections will be performed by the dam operator on a monthly basis and also during and after unusual events such as heavy rainfall or an earthquake.

Inspection Items: During each inspection the following items should be noted in particular.

1. Water Level - Maximum reservoir levels as a result of heavy rainfall should be recorded.
2. Earth Embankment - Walk the crest, side slopes and downstream toe of the dam concentrating on surface erosion, seepage, cracks, settlement, slumps, slides, and animal burrows. These are described as follows:
 - Surface Erosion - Removal of vegetative cover by water action or pedestrian or vehicle usage forming deep ruts or gullies.
 - Seepage - The passage of water through and/or underneath the earth embankment abutment and natural groundline or at the contact between the embankment and

outlet works. It can be indicated by cattails or other wet environmental vegetation, erosion, channelization, or slumping on the embankment face.

- Cracks - Deep cracks usually indicate the movement of the dam and/or the foundation and can be in either the longitudinal (along the length of the dam) or transverse (across the dam) directions. Cracking can be an indicator of the beginning of slumps. Shallow cracks may develop during the summer when the surface soils of the embankment become severely dried and are usually of no concern in regard to the safety of the dam.
 - Settlement - Settlement is indicated by depressions or low spots and can be signs of consolidation of the dam or foundation or the loss of material beneath the settlement area.
 - Slumps/Slides - A slow or sudden movement of the earth embankment slope on either face toward the toe of the dam.
 - If seepage indicates the presence of soil particles, or if deep cracks, settlement, slumps, or slides are noticed, a qualified engineer should be contacted immediately for consultation.
 - Animal Burrows - Animal burrows result in a loss of earth embankment material and can provide seepage paths for water through the embankment.
3. Gypsum Embankment - Walk the crest, side slopes and downstream toe of the dam concentrating on surface erosion, seepage, cracks, settlement, slumps, slides and animal burrows. The descriptions for these are the same as for earth embankment.
 4. Vegetation - Grass should be a thick vigorous growth to stabilize the earth embankment soils and prevent erosion from occurring. Note the height of the grass; if greater than 1 foot a mowing of the area should be scheduled before the next inspection. There should be NO trees on the earth embankment and NONE within a minimum of 20 feet of the embankment toes or other structures. The gypsum embankment will not be seeded and is not expected to have any vegetation.
 5. Gypsum Stack piezometers should be inspected for any damage or loss of function. Damaged piezometers must be promptly repaired or replaced since their function is critical to ensuring stability of the gypsum stack.
 6. The water level in each Gypsum Stack piezometer must be measured and recorded during each monthly inspection. If the water level in any piezometer is above the “critical elevation” as discussed in Section 4.5.2 of this plan, the Ameren Technical Services Superintendent should be notified and the **Emergency Action Plan should be immediately consulted for guidance on an appropriate course of action.**

7. Gypsum Pond LD/LCRS Drains - The change in location or amount of flows discharging from the Leak Detection/Leachate Collection Recovery System (LD/LCRS) should be recorded. If a significant change has occurred, a qualified engineer should be contacted for consultation.
8. Gypsum Stack Ring Drains - The change in location or amount of flows discharging from the Ring Drains should be recorded. If a significant change has occurred, a qualified engineer should be contacted for consultation.
9. Gypsum Stack Fixed Decant – Check the alignment and supports for the pipe. Record the amount of flows discharging from the pipe and any erosion or scour around the discharge point.
10. Gypsum Stack Perimeter Ditch – The perimeter ditch should have a consistent prismatic shape for the entire length. Inspect the perimeter ditch for evidence of erosion, sediment deposition and irregularity in channel geometry, especially in the vicinity of siphon, decant or ring drain outfall structures. If irregularities are noted, repairs should be scheduled and completed.
11. Drawdown Facilities - Check to make sure that the drawdown stop logs in the transfer ditch are undamaged, operating well and allowing for the free flow of water over them. Confirm during inspections the valves are opened and closed at least quarterly.
12. Transfer Channel - Check for any debris or other obstructions which may block or restrict the free flow of water. Check for any pools or undulation of the floor of the channel.
13. Recycle Pond Decant - Check for any debris or other obstructions around the Recycle Pond decant which may block or restrict the free flow of water. The emergency dewatering valve should be lubricated. If there is no return water in the pipe, the emergency dewatering valve should be exercised. Record the physical and operating conditions of the system.
14. Recycle Pond Drop Inlet Spillways - Check for any debris or other obstructions around the inlet crest and at the bottom of the drop inlet which may block or restrict the free flow of water. Check for the development of any rusty areas on the concrete, and seepage, cracking, breaking, or spalling of the concrete. Check for settlement or cracking of the crest. Check for any debris in the pipes which may restrict the flow of water. Check for any tears or leaks in the HDPE liner covering the concrete.
15. Recycle Pond Rip Rap Basin - Check for any debris or other obstructions in the riprap basin which may block or restrict the free flow of water. Check to make sure that the rip rap is remaining in a uniform position. Freeze/thaw action or flow over the rip rap may tend to lift or fracture, thus requiring replacement or leveling to maintain the necessary level of protection. NO trees or woody vegetation should be growing through the rip rap.

16. Fences - Check for damage, accumulated debris, operation of gates and locks, and adequacy of locations (this may change with time as people access the area or development occurs in the area).
17. Perimeter - Check the perimeter of the dams for a distance of at least 100 feet beyond the toe for signs of seepage or boils.
18. HDPE Liner – Wherever exposed, the HDPE Liner should be inspected for tears, gouges, protrusions under the liner and abrasion.

Records: A log book of activities occurring at the dam is to be kept current by the dam operator. The log book should be reviewed during the Engineering Inspection. This book should contain at the least the following documentation:

1. Completed operation and maintenance inspection checklists
2. Readings from all piezometers on the Gypsum Stack
3. Additional visual observations
4. A list of maintenance performed
5. A list of any unusual occurrences at the dam
6. Copies of the engineering inspection reports

4.6.2 Engineering Inspection

The engineering inspection is to be conducted by a qualified engineer approved by Ameren. The inspection will provide a thorough evaluation of the dam condition and appurtenances. Appendix B is an example of the inspection report form which is to be utilized for these inspections.

Frequency: The Gypsum Pond Dam is a Class I, High Hazard Potential dam and is to be inspected by an Illinois Registered Professional Engineer at least once per year. The Recycle Pond Dam is classified as a Class III, Low Hazard Potential dams and is to be inspected by an Illinois Registered Professional Engineer at least once every five years.

Inspection Items: The engineer will thoroughly inspect all of the items noted in Section 4.6.1 Operation and Maintenance Inspection.

Records: The Dam Inspection Report form from IDNR-OWR “Guidelines and Forms for Inspection of Illinois Dams” (a copy of which is included in Appendix B), will be completed by the inspecting engineer and will be signed and sealed by an Illinois Registered Professional Engineer. This report will document problem areas and deficiencies; recommend remedial actions for problem areas; and establish time requirements for dealing with the problems. The original report will be retained in Dynegy Operating Company (DOC) files, and a copy of the report will be submitted to the Illinois Department of Natural Resources, Office of Water Resources.

4.6.3 Review of Emergency Action Plan

The emergency action plan should be reviewed annually to assure that all contacts, addresses and telephone numbers are current. Changes in the adjacent land use should also be noted and may dictate the need for revisions to the plan. Changes to the plan should be made as appropriate but only with the concurrence of the Montgomery County Emergency Services and Disaster Agency and of the Illinois Department of Natural Resources, Office of Water Resources. Copies of any revisions should also be forwarded to all personnel and known emergency responders that possess previous versions the plan.

SECTION 5.0
MAINTENANCE ACTIVITIES

Timely repairs are a must after problem areas have been identified. The dam operator is to perform the work required to correct items noted in the operation and maintenance inspections and engineering inspections. Such items include repairing erosion of the gypsum slopes, mowing, seeding, tree and brush removal, replacing rip rap, repairing fences and locks, clearing debris, etc. The maintenance activities specified in the following sections are minimum requirements. NOTE: NO alterations or repairs to structural elements should be made without the assistance of the Ameren Chief Dam Safety Engineer and the concurrence of the Illinois Department of Natural Resources, Office of Water Resources.

Debris: Remove all trash, logs and other debris which may obstruct flow into the principal spillway pipes and drop inlets, or block passage from their discharge channels.

Rip Rap: Replenish rip rap as needed to provide adequate protection against erosion.

Vegetation Control

1. Maintain a good grass cover on the embankment by seeding, fertilizing and mulching areas which are refilled, barren, or thinly vegetated. Seeding mixtures used for maintenance reseeding shall result in a cover compatible with adjacent cover. The seeding mixture specified at the time of the dam's construction was IDOT Standard Specifications Class 1A (Salt Tolerant Lawn Mixture) as follows:

IDOT Class 1A Salt Tolerant Lawn Mixture

Bluegrass	60 lb/acre
Perennial Ryegrass	20 lb/acre
Dawsons Red Fescue.....	20 lb/acre
Scaldis Hard Fescue	20 lb/acre
Fults Salt Grass	60 lb/acre

2. Grassed areas such as the embankment and the areas beyond the embankment toes for a distance of at least 20 feet should be mowed at least twice annually or at any time the height of the grass exceeds 1 foot.
3. All erosion areas will be filled and compacted, reseeded, fertilized and mulched to establish a thick erosion resistant cover.
4. Remove all trees and brush growing on the dam embankment to prevent development of a root system which could provide seepage paths. Herbicides utilized for tree and brush control are discussed in Appendix D.
5. Keep the riprap basin clear of weeds, brush, and trees.

6. Clear all brush and trees for a distance of approximately 20 feet beyond the toe of each dam.

Animal Damage: Fill rodent holes and other animal burrows with compacted clayey soil and reseed. If rodents become a nuisance, an effective rodent control program as approved by the Illinois Department of Natural Resources District Wildlife Biologist should be implemented.

Signs: All warning signs shall be maintained (repaired, painted, or replaced) as needed.

Gypsum Slopes: Erosion of the gypsum slopes will be evident with the presence of erosion rills. Erosion rills should be filled with additional gypsum material and graded to conform with the design slope.

Piezometers: All piezometers on the gypsum stack shall be inspected for signs of damage or displacement. Non-functioning piezometers shall immediately be replaced.

APPENDIX A
LOCATION MAP

APPENDIX B
OPERATION AND MAINTENANCE INSPECTION CHECKLIST

OPERATION AND MAINTENANCE INSPECTION CHECKLIST

Dam Name (circle one): Gypsum Pond Dam Recycle Pond Dam

Date: _____ Time: _____

Name of Inspector: _____

Reservoir Elevation: _____ feet

<u>ITEM</u>	<u>NO</u>	<u>YES</u>	<u>IF YES</u>
Record Piezometer Readings for Gypsum Stack. Are any readings above the critical level? (see section 4.5.2 of O&M Manual)			Contact Manager, Environment & Chemistry and notify Hanson Professional Services
Note the condition of the Piezometers on the Gypsum Stack. Any damage?			Contact Manager, Environment & Chemistry
Deep Surface Cracks			Contact Manager, Environment & Chemistry
Slump or Slide on the upstream or downstream face			Contact Manager, Environment & Chemistry
Erosion from runoff, wave action or traffic			Repair and stabilize
Embankment, abutment or spillway seepage			Contact Manager, Environment & Chemistry
Seepage or flows of muddy water			Contact Manager, Environment & Chemistry
Uneven settlement			Contact Manager, Environment & Chemistry
Trees, brush or burrow holes on the embankment or in the riprap basin			Remove trees and brush, fill holes
Transfer channel or Spillway pipes blocked			Clear immediately
Damage to stop logs			Repair or replace
Damage to HDPE Liner			Repair and schedule engineer inspection
Settlement or displacement of Gypsum Pond fixed decant pipes or outlets			Schedule engineer inspection
Discharge from Gypsum Pond LD/LCRS Drains?			Record discharge rate for each outlet (time to fill bucket)
Discharge from Gypsum Pond Ring Drains?			Record discharge rate for each outlet (time to fill bucket)
Gypsum Stack Perimeter Ditch erosion			Schedule repair
Problems with Recycle Pond spillways			Contact Manager, Environment & Chemistry
Problems with Recycle Pond decant			Contact Manager, Environment & Chemistry
Height of grass (inches)		inches	If more than 1 foot, schedule mowing
Damage to fencing, gates and locks or other access restriction measures			Contact Manager, Environment & Chemistry
Confirm drawdown facilities are opened and closed at least quarterly.			Contact Manager, Environment & Chemistry

Comments:

APPENDIX C
ENGINEERING INSPECTION FORMS

Dam Inspection Report

Name of Dam _____ Dam Identification Number _____

Permit Number _____ Class of Dam _____

Location NW 1/4 Section 11 Township 7N Range 3W 3rd P.M.

Owner _____
Name Telephone Number (Day)

Street _____ Telephone Number (Night)

City _____ Zip Code _____ County Montgomery

Type of Dam _____

Type of Spillway _____

Date(s) Inspected _____

Weather When Inspected _____

Temperature When Inspected _____

Pool Elevation When Inspected _____

Tailwater Elevation When Inspected _____

Inspection Personnel:

Name Title

Name Title

Name Title

Name Title

Professional Engineer's Seal

The Department of Natural Resources is requesting information that is necessary to accomplish the statutory purpose as outlined under the River, Lakes and Streams Act, 615 ILCS 5 (1994 State Bar Edition). Submittal of this information is REQUIRED. Failure to provide the required information could result in the initiation of non-compliance procedures as outlined in Section 702.160 of the "Rules for Construction and Maintenance of Dams". This form has been approved by the State Forms Management Center.

CONDITION CODES

<u>EC</u>	:	<u>Emergency Condition. A serious dam safety condition exists that needs immediate action. Emergency measures implemented as instructed by Chief Dam Safety Engineer; such as, pool draw down, work stoppage, plant stoppage.</u>
<u>NE</u>	:	<u>No evidence of a problem</u>
<u>GC</u>	:	<u>Good condition</u>
<u>MM</u>	:	<u>Item needing minor maintenance and/or repairs within the year, the safety or integrity of the item is not yet imperiled</u>
<u>IM</u>	:	<u>Item needing immediate maintenance to restore or ensure its safety or integrity. Remediation should be completed within 1 month.</u>
<u>EC</u>	:	<u>Emergency condition which if not immediately repaired or other appropriate measures taken could lead to failure of the dam</u>
<u>OB</u>	:	<u>Condition requires regular observation to ensure that the condition does not become worse</u>
<u>NA</u>	:	<u>Not applicable to this dam</u>
<u>NI</u>	:	<u>Not inspected - list the reason for non-inspection under deficiencies</u>
<u>EC</u>	:	<u>Emergency Condition. A serious dam safety condition exists that needs immediate action. Emergency measures implemented as instructed by Chief Dam Safety Engineer; such as, pool draw down, work stoppage, plant stoppage.</u>

GYP SUM STACK - EARTH EMBANKMENT

ITEM	CONDITION	DEFICIENCIES	RECOMMENDED REMEDIAL MEASURES & SCHEDULE
Surface Cracks			
Vertical and Horizontal Alignment of Crest			
Unusual movement or Cracking at or Beyond Toe			
Sloughing or Erosion of Outer Embankment Slopes			
Upstream Face Slope Protection (HDPE Liner)			
Seepage			
Animal Damage			

GYP SUM STACK - EARTH EMBANKMENT

(Continued)

ITEM	CONDITION	DEFICIENCIES	RECOMMENDED REMEDIAL MEASURES & SCHEDULE
Vegetative Cover			

GYPSUM STACK - GYPSUM EMBANKMENT

ITEM	CONDITION	DEFICIENCIES	RECOMMENDED REMEDIAL MEASURES & SCHEDULE
Surface Cracks			
Vertical and Horizontal Alignment of Crest			
Unusual movement or Cracking at or Beyond Toe			
Sloughing or Erosion of Outside Embankment Slopes			
Sloughing or Erosion of Inside Embankment Slopes			
Seepage			
Animal Damage			

GYPSUM STACK - GYPSUM EMBANKMENT

(Continued)

ITEM	CONDITION	DEFICIENCIES	RECOMMENDED REMEDIAL MEASURES & SCHEDULE
Condition of Piezometers on Gypsum Stack			
Piezometer Readings on Gypsum Stack Above Critical Level?			

GYPSUM STACK – PERIMETER DITCH

ITEM	CONDITION	DEFICIENCIES	RECOMMENDED REMEDIAL MEASURES & SCHEDULE
Ditch Geometry (15 ft bottom width, 3:1 slopes, 8-9 ft depth)			
Concrete Apron at ring drain outlets			
Ring Drain Discharge Pipes			
Stilling Wells for Fixed Decants			

TRANSFER CHANNEL - (between gypsum stack and recycle pond)

Drop Inlet Structure

Overflow Spillway Structure

Gated

ITEM	CONDITION	DEFICIENCIES	RECOMMENDED REMEDIAL MEASURES & SCHEDULE
Debris			
Side Slope Stability			
HPDE Liner			
HDPE Liner Welds			
Stop Logs			
Differential Settlement			

RECYCLE POND - EMBANKMENT

ITEM	CONDITION	DEFICIENCIES	RECOMMENDED REMEDIAL MEASURES & SCHEDULE
Surface Cracks			
Vertical and Horizontal Alignment of Crest			
Unusual movement or Cracking at or Beyond Toe			
Sloughing or Erosion of Outer Embankment Slopes			
Upstream Face Slope Protection (HDPE Liner)			
Seepage			
Animal Damage			

RECYCLE POND - EMBANKMENT

(Continued)

ITEM	CONDITION	DEFICIENCIES	RECOMMENDED REMEDIAL MEASURES & SCHEDULE
Vegetative Cover			

RECYCLE POND - PRINCIPAL SPILLWAY (Left, Looking Downstream)

Drop Inlet Structure

Overflow Spillway Structure

Gated

ITEM	CONDITION	DEFICIENCIES	RECOMMENDED REMEDIAL MEASURES & SCHEDULE
Alignment of Structure Walls			
Construction Joints			
Differential Settlement			
Erosion, Spalling, Cavitation			
Joint Separation			
Seepage Around or into Conduit			
Surface Cracks			

RECYCLE POND - PRINCIPAL SPILLWAY (Left, Looking Downstream)

(Continued)

Drop Inlet Structure

Overflow Spillway Structure

Gated

ITEM	CONDITION	DEFICIENCIES	RECOMMENDED REMEDIAL MEASURES & SCHEDULE
Structural Cracks			

RECYCLE POND - PRINCIPAL SPILLWAY (Center)

Drop Inlet Structure

Overflow Spillway Structure

Gated

ITEM	CONDITION	DEFICIENCIES	RECOMMENDED REMEDIAL MEASURES & SCHEDULE
Alignment of Structure Walls			
Construction Joints			
Differential Settlement			
Erosion, Spalling, Cavitation			
Joint Separation			
Seepage Around or into Conduit			
Surface Cracks			

RECYCLE POND - PRINCIPAL SPILLWAY (Center)

(Continued)

Drop Inlet Structure

Overflow Spillway Structure

Gated

ITEM	CONDITION	DEFICIENCIES	RECOMMENDED REMEDIAL MEASURES & SCHEDULE
Structural Cracks			

RECYCLE POND - PRINCIPAL SPILLWAY (Right, Looking Downstream)

Drop Inlet Structure

Overflow Spillway Structure

Gated

ITEM	CONDITION	DEFICIENCIES	RECOMMENDED REMEDIAL MEASURES & SCHEDULE
Alignment of Structure Walls			
Construction Joints			
Differential Settlement			
Erosion, Spalling, Cavitation			
Joint Separation			
Seepage Around or into Conduit			
Surface Cracks			

RECYCLE POND - PRINCIPAL SPILLWAY (Right, Looking Downstream)

(Continued)

Drop Inlet Structure

Overflow Spillway Structure

Gated

ITEM	CONDITION	DEFICIENCIES	RECOMMENDED REMEDIAL MEASURES & SCHEDULE
Structural Cracks			

RECYCLE POND - ENERGY DISSIPATOR

Principal Spillway

Outlet Works

Type:

FHWA HEC-14, Riprap Basin

ITEM	CONDITION	DEFICIENCIES	RECOMMENDED REMEDIAL MEASURES & SCHEDULE
Riprap			
Outlet Channel			
Debris			

RECYCLE POND - DECANT STRUCTURE

ITEM	CONDITION	DEFICIENCIES	RECOMMENDED REMEDIAL MEASURES & SCHEDULE
Alignment			
Connection to Bollard			
Debris in Inlets			
Condition of Pipe			
Condition of Liner Beneath Pipe			
Connection to Ballast			
Connection of Pipe Boot to Liner			

RECYCLE POND - DECANT STRUCTURE

(continued)

ITEM	CONDITION	DEFICIENCIES	RECOMMENDED REMEDIAL MEASURES & SCHEDULE
Seepage Around or into Conduit			

APPENDIX D
HERBICIDES

HERBICIDES

Site personnel should check with the Illinois Department of Natural Resources, Regional Fisheries Biologist and the Regional Wildlife Biologist before using any herbicide. Read the product label prior to use and follow the use directions and precautions accordingly.

On March 1, 1979 the U.S. Environmental Protection Agency (U.S.E.P.A.) halted the use of the herbicide 2, 4, 5-T in parks and recreation areas. The use of silvex (2, 4, 5-TP) around water has also been banned.

The Agronomy Department at the University of Illinois and the Aquatic Biology Section of the Department of Natural Resources, Office of Scientific Research and Analysis indicate that the herbicides containing the 2, 4-D or 2, 4-DP are legal for use in parks and recreation areas and effective for controlling brush and woody growth. Some examples of approved herbicides are:

1. Tordon RTU by DOW Chemical. (Can be obtained with blue dye.)
2. WEEDONE 170 by Union Carbide
3. WEEDONE, 2, 4-DP by Union Carbide
4. A 1% to 2% solution of ROUNDUP
5. Garlon by DOW Chemical
6. Banvel by Sandoz

Your distributor may carry brand name herbicides other than those listed above. Be certain that the product does not contain the ingredients 2, 4, 5-T or 2, 4, 5-TP. An example of an unacceptable product is ESTERON 2, 4, 5 by DOW Chemical.

APPENDIX E
CONSTRUCTION DRAWINGS



Appendix G: Photos of 2015 Sloughing Repairs



Figure G.1. Photo of 2015 sloughing prior to repairs.



Figure G.2. Photo of 2015 sloughing prior to repairs.



Figure G.3. Photo of 2015 sloughing area after repairs.



Figure G.4. Photo of 2015 sloughing area after repairs.